

Publication No 00-4225

A
WORKSHOP MANUAL

For the Three Cylinder

TRIUMPH TRIDENT
MODEL T160

750cc (45 cubic inch)

with Electric Starter

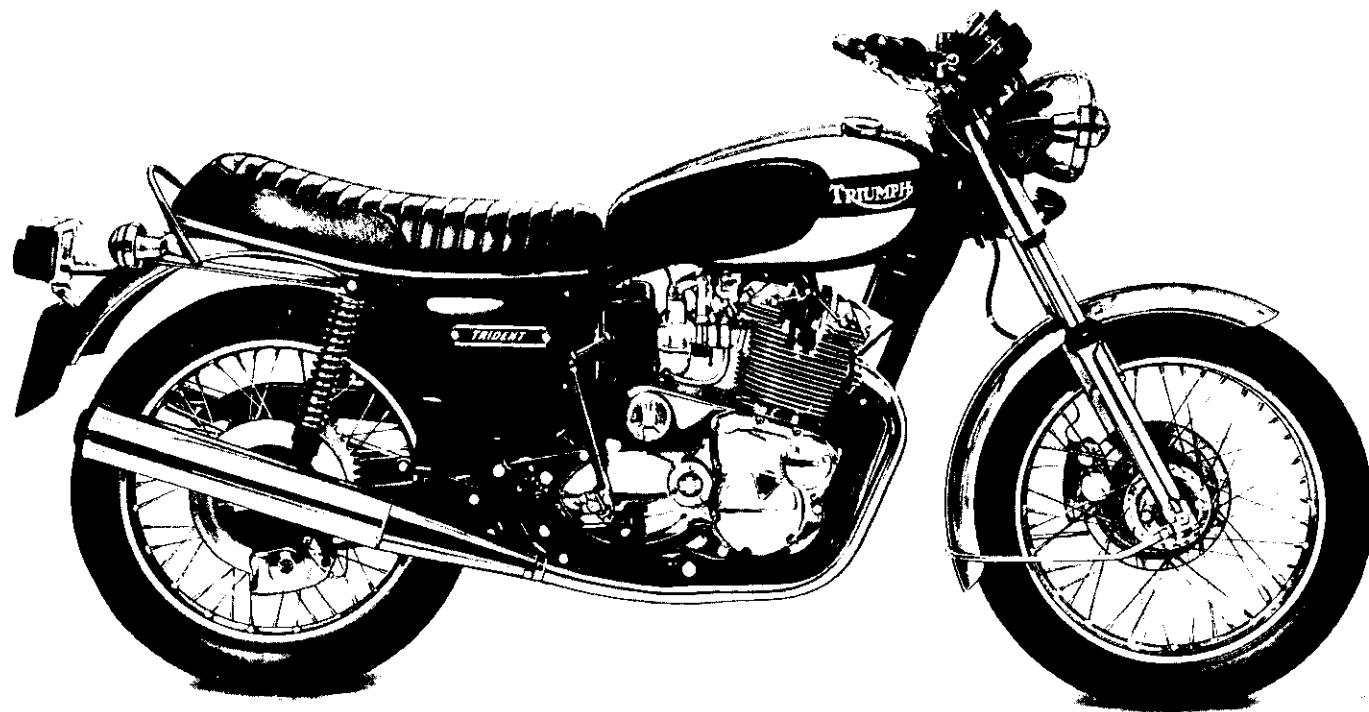
1975

From Engine Number 00101

Compiled by John R. Nelson M.A. Eng (CANTAB) M.I.Mech.E.

© Copyright by J.R. NELSON
Published by J.R. Technical Publications
Printed by Warwick Printing Ltd.,
Theatre Street,
Warwick.

Published April 1982



TRIDENT MODEL T160.

FOREWORD

All Triumph Trident T150 and T160 Models incorporated the same engine and frame numbering principles utilising a two letter prefix prior to the machines own individual number. This was followed immediately by the model type designation, the complete sequence preceeded and ended by a circular stamped limiting ident thereby preventing any subsequent form of illegal alteration or amendment.

The engine number is to be found on the left side of the engine, immediately below the cylinder block flange, the numbers being stamped onto a raised embossed pad – a further aid to counterfeiture.

The prefix letters indicate both year and month of manufacture.

The first prefix letter indicates the month and year of manufacture as follows:-

Month of Manufacture	Year of Manufacture
A January	J 1974
B February	K 1975
C March	N 1976
D April	P 1977
E May	X 1978
G June	A 1979
H July	B 1980
J August	
K September	
N October	
P November	
X December	

The third section is a numerical block of five figures which comprise the engine number commencing at 00101.

The fourth section indicated the model designation.

Example	Month	Year	Number	Model
	N	J	00101	T160

The frame number is stamped on the left side of the frame, in front of the fuel tank.

The frame bears the same serial number as the engine unit fitted into it and hence were identical at the time of original manufacture.

ANCILLARY EQUIPMENT AND PROPRIETARY FITTINGS

Carburettors	Amal Ltd. Holdford Road Witton Birmingham 6.
Chains	Renold Chains Ltd. Wythenshawe Manchester.
Electrical Equipment	J Lucas Ltd. Great Hampton Street, Birmingham 18.
Rear Suspension	Girling Ltd. Birmingham Road, West Bromwich Staffs.
Sparking Plugs	Champion Sparking Plug Company Ltd. Feltham Middx.
Instruments	Smiths Industries Ltd. Cricklewood Works London NW2.
Tyres	Dunlop Rubber Company Ltd. Fort Dunlop Birmingham 24.

ACKNOWLEDGEMENTS

The compilation of this publication results from generous and accurate contributions made from former colleagues Jack Harper and Arthur Lupton, both previously for many years with the B.S.A. Service Department, and with practical help and advice from many friends, including Harry Woolridge of Triumph Motorcycles (Meriden) Ltd., and of course Leslie Williams the proud owner of 'Slippery Sam', perhaps the most famous Trident of them all.

Due to the tortuous path of ownership of the names of Triumph, B.S.A., N.V.T.M. and 'TRIDENT', grateful acknowledgement is freely given to Mr. Dennis Poore, N.V.T., the Receiver N.T.I. Ltd., Messrs Cork Gully & Co. and to Triumph Motorcycles (Meriden) Ltd. for permission to proceed with and produce this Manual, utilising (where appropriate) existing technical matter and artwork previously used on Triumph Trident publications, which has proved so invaluable in the compilation and completion of this project.

J.R.N.
December 1981.

DISCLAIMER

Whilst every endeavour has been made by all those contributing to this publication to assure and maintain its technical accuracy, it must be appreciated that compilation a number of years after the closure of the factory where manufacture took place and the loss of the associated design and development facility, with consequent disbandment of the original drawing facilities and records, those responsible for the composition and publication of this Workshop Manual, cannot accept any responsibility whatsoever for any errors, or any damage or damages arising or ensuing from such errors in any way whatsoever.

INTRODUCTION TO THIS MANUAL

This Workshop Manual has been compiled to provide service information for 750cc (45 cu.in.) TRIUMPH T160 ELECTRIC START 'TRIDENT' MODEL owners wishing to carry out basic maintenance overhaul and repair work on both this early T150 and the later T160 Electric Start versions of this model.

The technical content has been brought together and presented in a matching style to that of the original factory T150 model workshop manual, but has of course been totally updated and rewritten to incorporate not only the features specifically exclusive to the Electric Start version of the Trident, but at the same time cover the Disc Front and Rear Brakes incorporated on some of the later T150 and Rocket 3 Models; details of which were not included in the earlier T150 Model and Rocket 3 Workshop Manuals of that time. This version then should also be of considerable assistance to late T150 Trident and Rocket 3 owners in this category. The actual procurement and collation of the technical information to provide this Publication achieved finality some considerable time following closure of Norton Villiers Triumph International at Kitts Green in Birmingham, when co-incidentally the production of the actual Triumph T160 Electric Start Model of the Trident, being built and assembled at the B.S.A. Factory at Small Heath came to a final end.

The total staff involved in the design, manufacture, production and servicing of this machine thereby having become made redundant quietly folded their tents and disappeared their many and several ways in search of fresh fields and pastures new. The collected T160 Model knowledge was suddenly dispersed and scattered overnight. It was felt that the accumulated knowledge of the writers Colleagues should not be lost following the demise of this famous name and that every attempt should be made to preserve and present this information for the record and for ultimate use. The writer therefore decided to collect whatever material that was immediately available, and then seek the urgent aid of his colleagues (the actual Technical Staff from the original Company making the Trident.)

Generous contributions and material has enabled this manual to be brought to completion and although it is now some considerable time after the end of the manufacture of the model concerned it was nevertheless felt that the full range of information contained herein would undoubtedly prove invaluable to current Trident owners wishing to keep this prestigious machine in first class condition, even more importantly as the inevitable time approaches, be totally authoritative for those who will inevitably be engaged on the overhaul and ultimate restoration of this much sought after representative of a very successful high performance motorcycle.

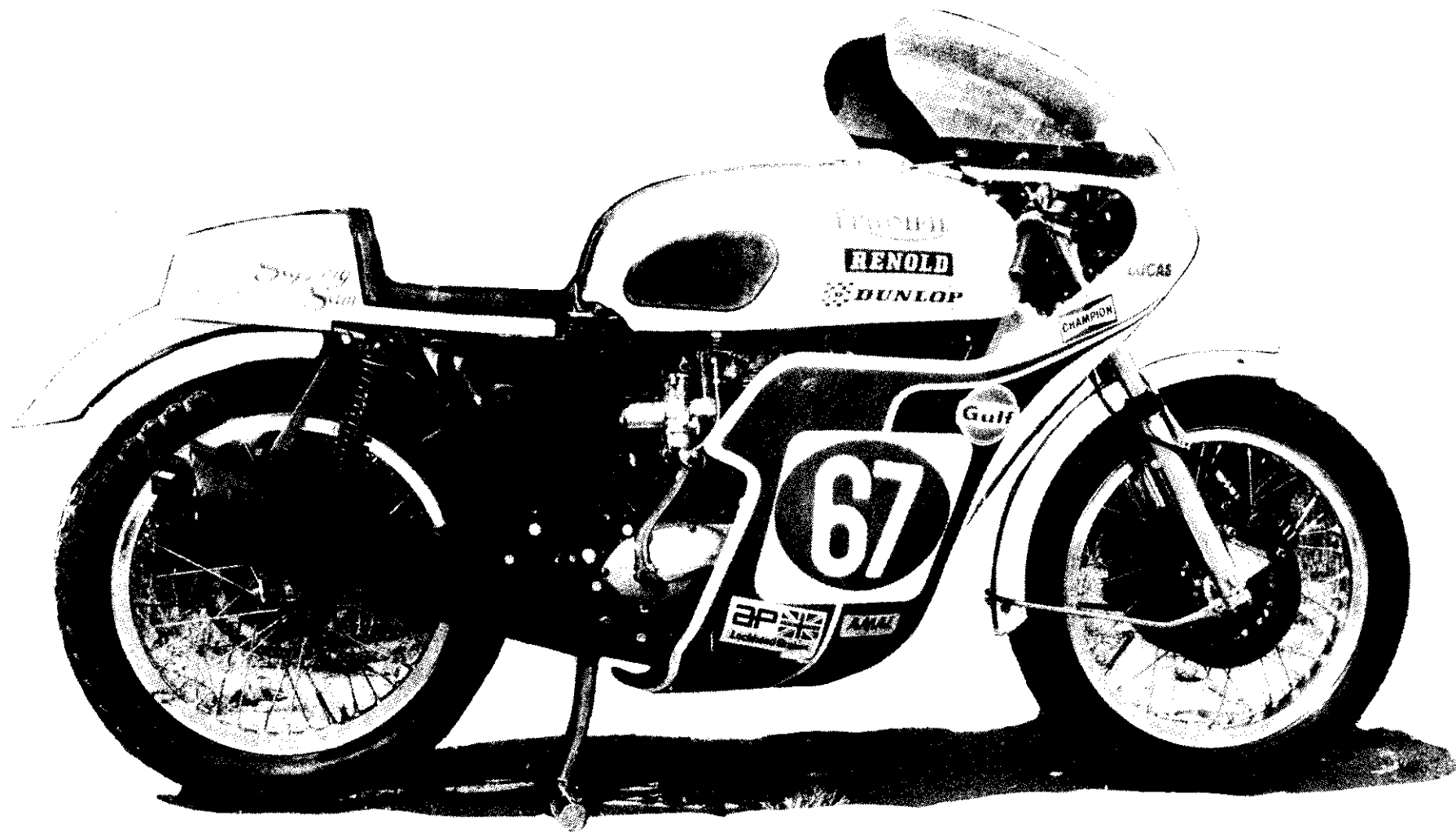
The first section of this manual therefore provides a GENERAL DATA SECTION in Ready Reference form, detailing all the original and recommended drawing and manufacturing dimensional data of all moving and wearing components and indicating the established optimum fits, limits and tolerances.

The layout of this general data section follows the same sequence of the main sections in the body of the manual, corresponding to normally established procedures of strip down, examination and rebuild.

The T160 'ELECTRIC START' version electrical equipment is fully described and illustrated, followed by a final section which deals with the originally recommended service tools some of which were developed, drawn, part numbered but sadly never saw the light of day; others which most likely by now prove to be no longer available. However the author felt that it would be worthwhile including the illustrations and references to allow the well equipped or keenly adaptable reader to devise his own methods and solutions along the lines so indicated, thereby allowing proper protection of the components during the operation in the manner originally intended.

It has always been accepted as useful practice to include in any manual the relevant Conversion and Reference Charts. Here we have also included those previously found useful from the earlier publication, and will be found at the end of this Manual.

John R. Nelson



"SLIPPERY SAM" IN FULL SPLENDOUR

CONTENTS

	SECTION
GENERAL DATA	GD
LUBRICATION SYSTEM	A
ENGINE	B
PRIMARY DRIVE	C
TRANSMISSION (GEARBOX)	D
FRAME & ATTACHMENTS	E
WHEELS, BRAKES & TIRES	F
FRONT FORK	G
ELECTRICAL SYSTEM	H
SERVICE TOOLS	J
CONVERSION CHARTS	CT

GENERAL DATA

TRIDENT

MODEL T160

750 c.c. (45 cu. ins.)

GENERAL DATA

MODEL T160 TRIDENT

LUBRICATION SYSTEM

OIL PUMP

Pump drive ratio	1.9 : 1 (engine to pump)
Type	Gear (duplex)

OIL PUMP DRIVE

Intermediate gear—Bore5625/.5620 in. (14.287/14.2748 mm.)
Bush—Bore4387/.4382 in. (11.143/11.1302 mm.)
—Length755/.745 in. (19.177/18.923 mm.)
Spindle—Diameter4360/.4357 in. (11.0744/11.0668 mm.)

OIL PRESSURE RELIEF VALVE

Release pressure	85–75 p.s.i. (5.976–5.273 kg/cm ²)
------------------	-----	-----	-----	-----	-----	-----	-----	-----	-----	--

OIL PRESSURE

Normal running	85–75 p.s.i. (5.976–5.273 kg/cm ²)
Switch operating pressure	3–5 p.s.i. (0.211 kg/cm ² –0.352 kg/cm ²)

ENGINE

BASIC DETAILS

Bore and stroke	67 × 70 mm. (2.637 in. × 2.756 in.)
Capacity	740 cm ³ (45.2 cu. in.)
Compression ratio	9.5 : 1

CRANKSHAFT

Crankshaft type	EN16B hardened and tempered stamping-one piece
Main bearing (drive side) size and type	1 $\frac{1}{8}$ × 2 $\frac{1}{8}$ × $\frac{1}{8}$ in. (caged ball)
Main bearing (centre) running clearance0005/.0022 in. (.0127/.0558 mm.)
Main bearing (timing side) size and type	25 mm × 52 mm × 15 mm (roller)
Left main bearing housing diameter	2.8100/2.8095 in. (71.3740/71.3613 mm.)
Left main bearing journal diameter	1.1242/1.1245 in. (28.5699/28.5623 mm.)
Centre main bearing housing diameter	2.0630/2.0625 in. (52.4002/52.3875 mm.)
Centre main bearing journal diameter	1.9170/1.9175 in. (48.6918/48.7045 mm.)
Right main bearing housing diameter	2.0447/2.0457 in. (51.9344/51.9608 mm.)
Right main bearing journal diameter	0.9843/0.9840 in. (25.0012/24.9936 mm.)
Big end journal diameter	1.6240/1.6235 in. (41.2496/41.2369 mm.)
Min. regrind diameter	1.6200/1.6195 in. (41.148/41.1353 mm.)

CONNECTING RODS

Length (centres)	5.751/5.749 in. (14.6075/14.6024 mm.)
Big end bearings type	Bi-metal, Steel backed
Con rod side clearance008/.014 in. (0.2032/0.3556 mm.)
Bearing diametral clearance0005/.0020 in. minimum (.0127/.0508 mm.)

WRIST PIN (GUDGEON PIN)

Clearance in con-rod005/.0011 in. (0.127/.0279 mm.)
Diameter6883/.6885 in. (17.4828/17.4880 mm.)
Length	2.250/2.235 in. (57.150/56.769 mm.)

CYLINDER BLOCK

Material	Aluminum Alloy
Bore	2.6366/2.6363 in. (66.9696/66.962 mm.)
Maximum oversize (see also page 00)	+ .040 in. (1.016 mm.)
Tappet guide block housing diameter	1.1562/1.1557 in. (29.3675/29.3548 mm.)
Liner material	Austenitic steel

CYLINDER HEAD

Material	Alum alloy die casting
Inlet port size	1 $\frac{1}{8}$ " dia. (28.575mm) (c'bore 1 $\frac{1}{4}$ " (31.75mm))
Exhaust port size	1 $\frac{1}{8}$ " dia. (31.75 mm.)
Valve seatings:	
Type	Cast-in
Material	Cast iron

VALVES

Stem diameter: Inlet3100/.3095 in. (7.8740/7.8613 mm.)
Exhaust3095/.3090 in. (7.8613/7.8495 mm.)
Head diameter: Inlet	1.534/1.528 in. (38.9636/38.812 mm.)
Exhaust	1.315/1.309 in. (33.401/33.2486 mm.)
Exhaust valve material	Chromium-Manganese-Nickel-Nitrogen valve steel (heat treated)

GENERAL DATA

GD

RATIOS

Internal ratios:	5th (Top) ...	1.00 : 1
	4th ...	1.19 : 1
	3rd ...	1.40 : 1
	2nd ...	1.837 : 1
	1st (Bottom) ...	2.585 : 1
Overall ratios:	5th (Top) ...	4.92
	4th ...	5.85
	3rd ...	6.89
	2nd ...	9.04
	1st (Bottom) ...	12.71
Engine R.P.M. @ 10 M.P.H. in 5th (Top) gear	...	663
Transmission sprocket teeth	...	19

GEAR DETAILS

Mainshaft high gear:		
Bearing type	...	$\frac{1}{8}$ " \times $1\frac{1}{8}$ " \times $\frac{7}{8}$ " Needle roller
Bearing length875/.865 in. (22.23-21.97 mm.)
Spigot diameter	...	1.5077/1.5072 in. (38.36-38.28 mm.)

GEARBOX SHAFTS

Mainshaft:		
Left end diameter8103/.8098 in. (20.58/20.57 mm.)
Right end diameter7494/.7498 in. (19.044-19.054 mm.)
Length	...	10.37 in. (263 mm.)
Layshaft:		
Left end diameter6875/.6870 in* (17.46/17.404 mm.)
Right end diameter6875/.6870 in. (17.46/17.404 mm.)
Length	...	6.47 in. (164.33 mm.)

BEARINGS

Mainshaft bearing (left) (Supplied with gear)	...	$1\frac{1}{2}$ \times $2\frac{1}{2}$ \times $\frac{5}{8}$ in. Roller bearing
Mainshaft bearing (right)	...	$\frac{3}{4}$ \times $1\frac{7}{8}$ \times $\frac{5}{16}$ in. Ball Journal
Layshaft bearing (left)	...	$\frac{1}{8}$ \times $\frac{7}{8}$ \times $\frac{1}{4}$ in. Needle roller
Layshaft bearing (right)	...	$\frac{1}{8}$ \times $\frac{7}{8}$ \times $\frac{1}{4}$ in. Needle roller
Layshaft 1st gear (bush fitted)		
Bore810/.809 in. (20.574/20.548 mm.)
Shaft diameter8075/.8070 in. (20.511/20.498 mm.)
Layshaft 2nd gear (bush fitted)		
Bore810/.809 in. (20.574/20.548 mm.)
Shaft diameter8075/.8070 in. (20.511/20.498 mm.)
Layshaft 4th gear (bush fitted)		
Bore8103/.8093 in. (20.582/20.556 mm.)
Shaft diameter8078/.8073 in. (20.518/20.505 mm.)

KICKSTART RATCHET MECHANISM

Bush bore751/.752 in. (19.0754/19.1008 mm.)
Spindle working clearance in bush0012/.0026 in. (.0304/.0660 mm.)
Ratchet spring free length	...	$\frac{1}{2}$ in. (12.7 mm.)

KICKSTARTER

Crank spindle dia.748/.747 in. (18.999-18.974 mm.)
Crank bush bore753/.752 in. (19.126-19.101 mm.)

GEARSHIFT MECHANISM

Plungers:		
Outer diameters4315/.4320 in. (10.9601-10.9728 mm.)
Working clearance in bore0005/.0015 in. (0.0127-.0381 mm.)
Plunger springs:		
No. of working coils	...	12
Free length	...	$1\frac{1}{4}$ in. (31.75 mm.)
Inner bush bore (Gearchange fork)5632/.5622 in. (14.3053-14.2799 mm.)
Clearance on shaft0025/.001 in. (0.0635-0.0254 mm.)
Outer bush bore753/.751 in. (19.1262-19.0754 mm.)
Clearance on shaft0045/.002 in. (0.1143-0.0508 mm.)
Quadrant return springs:		
No. of working coils	...	11
Free length	...	$1\frac{3}{4}$ in. (44.45 mm.)
Complete plunger spring:		
Free length	...	2.14 in. (58 mm.)
No. of working coils	...	19
Complete plunger housing bore4385/.4375 in. (11.138-11.1125 mm.)
Complete plunger diameter4365/.4355 in. (11.087-11.0617 mm.)

GEARSHIFT CROSS-SHAFT

Cross-shaft diameter	6250-6245 in. (15-875-15-8623 mm.)
Needle roller bearing	$\frac{5}{8}$ " $\frac{13}{16}$ " $\frac{7}{8}$ "
Link pin bore378-.376 in. (9-601-9-550 mm.)
Link pin diam.3751-.3749 (9-5275-9-5225 mm.)

STARTER MOTOR MECHANISM

Solenoid and bearing housing bush bore	1-0018-1-0013 in. (25-446-25-433 mm.)
Intermediate shaft diameter	1-0003-.9998 in. (25-407-25-395 mm.)
Adapter plate bush bore7530-.7518 in. (19-126-19-096 mm.)
Intermediate shaft bush bore4387-.4382 in. (11-143-11-130 mm.)
Intermediate shaft diameter4372-.4367 in. (11-105-11-092 mm.)

FRAME AND ATTACHMENT DETAILS

HEAD RACES

Taper roller (top and bottom)	Timken LM11949L;LM11910;LM11900E.
-------------------------------	-----	-----	-----	-----	-----	-----	-----	-----	-----	-----------------------------------

SWINGING FORK

Bush type	Pre-sized steel-backed—phosphor bronze
Bush bore	1-4460-1-4470 in. (36-7284-36-7538 mm.)
Bobbin diameter	1-4445-1-4450 in. (36-6903-36-703 mm.)
Distance between fork ends	7-81 in. (198-4 mm.)

REAR SUSPENSION

Type	Swinging fork controlled by combined coil spring/hydraulic damper units
Centres (extended unit)	12-875 (327 mm.) at mid position
Bush bore382-.377 in. (9-7028-9-5758 mm.)
Length of free spring	8-810 in. (223-8 mm.)
Spring rate	110 lbs./in.

WHEELS, BRAKES AND TIRES

WHEELS

Rim size: Front	WM2-19
Rear	WM3-19
Spoke details: Front Outer (L.H. and R.H.)	20 off 10 SWG 7-87 in. (overall length) 80° head
inner (L.H. and R.H.)	20 off 10 SWG 7-84 in. (mean length) 96° head
Rear: Inner (L.H. and R.H.)	20 off 10 SWG 7-84 in. (mean length) 96° head
Outer (L.H.)	10 off 10 SWG 8-16 in. (overall length) 75° head
Outer (R.H.)	10 off 10 SWG 8 in. (overall length) 80° head

WHEEL BEARINGS

Front and rear, dimensions and type	25 x 52 x 15 mm.—Ball Journals
Front spindle diameter (at bearing journals)9841-.9836 (24-9961-24-9821 mm.)
Rear sleeve diameter (at bearing journals)7873-.7868 (19-9974-19-9847 mm.)

REAR WHEEL DRIVE

Gearbox sprocket	See 'Transmission'.
Rear wheel sprocket teeth	50
Chain details:	
No. of links: Solo	110
Pitch	$\frac{1}{2}$ in.
Width	$\frac{1}{2}$ in.
Speedometer drive gearbox ratio	1-25 : 1
Speedometer cable length	70-5 in. (1791 mm.)

BRAKES

Operation	Hydraulic
Type	Disc
Diameter: Front	10 in. 254 mm.
Rear	10 in. 254 mm.
Brake pad (front)	A.P. 4741—537
Brake pad (rear)	A.P. 4741—570

TIRES

Size: Front	4-10 x 19 in.
Rear	4-10 x 19 in.
Tire pressure: Front	26 lb./sq. in. (1-828 kg./sq. cm.)
Rear	28 lb./sq. in. (1-97 kg./sq. cm.)

Kickstart ratchet pinion nut	40.45 lb.ft. (5.530.6.221 kg.m.)
Rotor fixing nut	50 lb.ft. (6.913 kg.m.)
Stator fixing nuts	8 lb.ft. (1.106 kg.m.)
Stanchion pinch bolts	25 lb.ft. (3.456 kg.m.)
Front wheel spindle cap bolts	23.25 lb.ft. (3.173.45 kg.m.)
Zener diode fixing nut	2.2.3 lb.ft. (.277.3174 kg.m.)
Fork cap nut	25.30 lb.ft. (3.45.4.14 kg.m.)
Clutch centre nut	60 lb.ft. (8.295 kg.m.)
Transmission (Gearbox) sprocket—Lock nut	58 lb.ft. (8.019 kg.m.)
Chainwheel shock absorber nut	75.80 lb.ft. (10.369.11.06 kg.m.)
Crankshaft centre bearing nuts	17.5.18.5 lb.ft. (2.41.2.55 kg.m.)
Engine sprocket nut	58.63 lb.ft. (8.00.8.69 kg.m.)
Camshaft pinion nut	75 lb.ft. (10.369 kg.m.)
Stanchion end plug	45.50 lb.ft. (6.21.6.90 kg.m.)
Engine mounting bolts								
Bottom	30.35 lb.ft. (4.14.4.83 kg.m.)
Front	30.35 lb.ft. (4.14.4.83 kg.m.)
Rear	23.25 lb.ft. (3.17.3.45 kg.m.)
Rear engine plates to frame	23.25 lb.ft. (3.17.3.45 kg.m.)
Rear damper bolts	18 lb.ft. (2.48 kg.m.)
Sump cover plate nuts	6 lb.ft. (.83 kg.m.)
Timing cover screws (bright zinc)	3.5.4.5 lb.ft. (.48.62 kg.m.)
Timing cover screws (yellow)	6.5.7.5 lb.ft. (.897.1.035 kg.m.)
Rocker box socket screws	6 lb.ft. (.83 kg.m.)
Front frame to rear								
Top	23.25 lb.ft. (3.17.3.45 kg.m.)
Bottom	30.35 lb.ft. (4.14.4.83 kg.m.)
Shock absorber assembly screws	2.3 lb.ft. (.277.414 kg.m.)

SECTION A

LUBRICATION SYSTEM

	<i>Section</i>
ROUTINE LUBRICATION	A1
TABLE OF RECOMMENDED LUBRICANTS	A2
ENGINE LUBRICATION SYSTEM	A3
CHANGING THE ENGINE OIL AND CLEANING THE OIL FILTERS	A4
OIL PRESSURE	A5
THE OIL PRESSURE RELEASE VALVE... ..	A6
REMOVING AND REPLACING THE OIL PUMP	A7
REMOVING AND REPLACING THE OIL COOLER	A8
REMOVING AND REPLACING THE ROCKER OIL FEED PIPE	A9
ANTI-DRAIN VALVE	A10
CONTACT BREAKER LUBRICATION	A11
TRANSMISSION (GEARBOX) LUBRICATION	A12
PRIMARY CHAINCASE LUBRICATION	A13
REAR CHAIN LUBRICATION AND MAINTENANCE	A14
GREASING THE STEERING HEAD RACES	A15
WHEEL BEARING LUBRICATION	A16
TELESCOPIC FORK LUBRICATION	A17
LUBRICATION NIPPLES	A18
LUBRICATING THE CONTROL CABLES	A19
SPEEDOMETER CABLE LUBRICATION	A20
REAR BRAKE SPINDLE LUBRICATION	A21
CHANGING THE OIL IN THE BRAKING SYSTEMS	A22

SECTION A1

ROUTINE LUBRICATION

	<i>Section</i>
Every 250 miles (400 Kms.)	
Check level in oil tank	A4
Every 1,000 miles (1,600 Kms.)	
Lubricate control cables	A19
Grease swinging fork pivot... ..	A18
Check brake pipes and brake connections	A14
Every 3,000 miles (3,800 Kms.)	
Check transmission oil level (Gearbox)	A12
Check front forks for external oil leakage	A17
Lubricate brake pedal spindle	A21
Remove rear chain for cleaning and greasing.	
Lubricate contact breaker and auto-advance mechanism.	
Grease speedometer drive unit.	
Change engine oil and primary chaincase oil.	
Renew full flow filter.	
Clean all filters.	
Every 6,000 miles (9,600 Kms.)	
Change oil in transmission (Gearbox)	A12
Change oil in front forks	A17
Every 12,000 miles (19,200 Kms.)	
Grease wheel bearings	A16
Grease steering head bearings	A15
Change oil in braking systems	A22

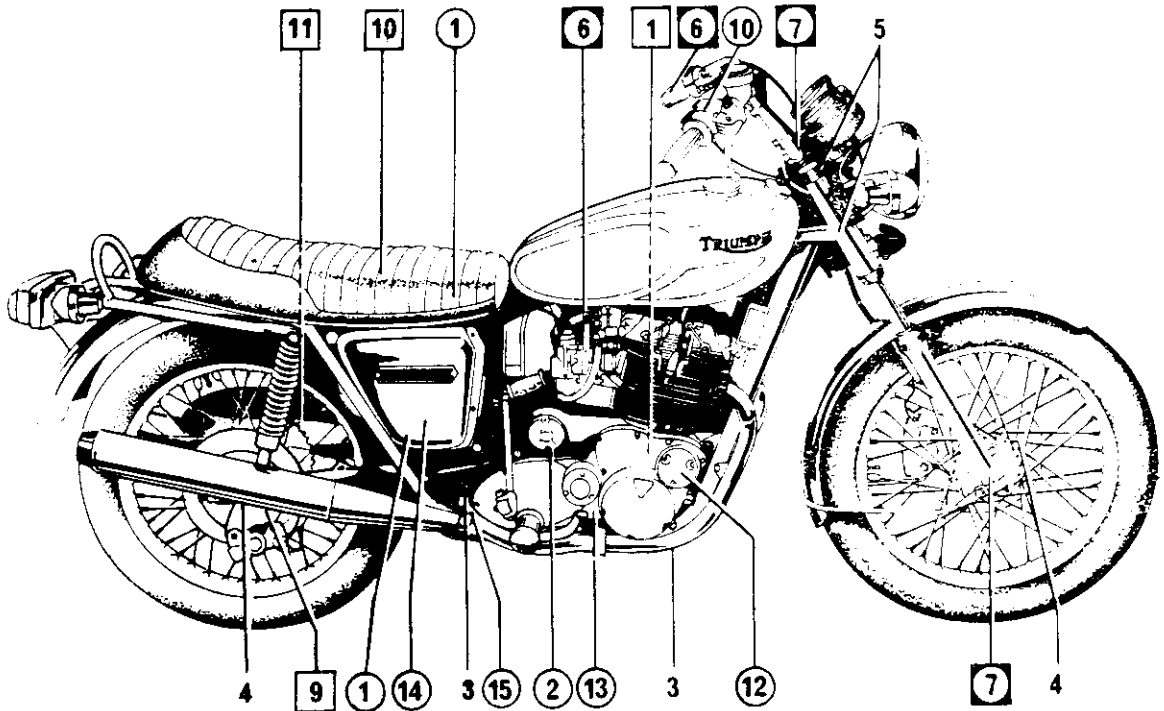


Fig. A1. LUBRICATION CHART

Numbers in circles refer to right side of machine
 Numbers in squares refer to left side of machine
 Other numbers refer to center of machine

Ref. No.	Description	S.A.E. Oil Grade
1	Engine oil tank	20/50
1	Primary chaincase	20/50
2	Transmission (gearbox)	90 E.P.
3	Oil filter compartment	20/50
4	Wheel bearings	Grease
5	Steering head bearings	Grease
6	Exposed cables, balljoints, linkage, carb. etc.	10/30
7	Telescopic fork	Auto trans. fluid
8	Swinging fork pivot	Grease
9	Speedometer drive unit	Grease
10	Hydraulic brake reservoirs	Spec 329 (D.O.T. 3-U.S.A.)
11	Rear chain	20/50
12	Contact breaker and auto-advance	Thin Grease 20 50

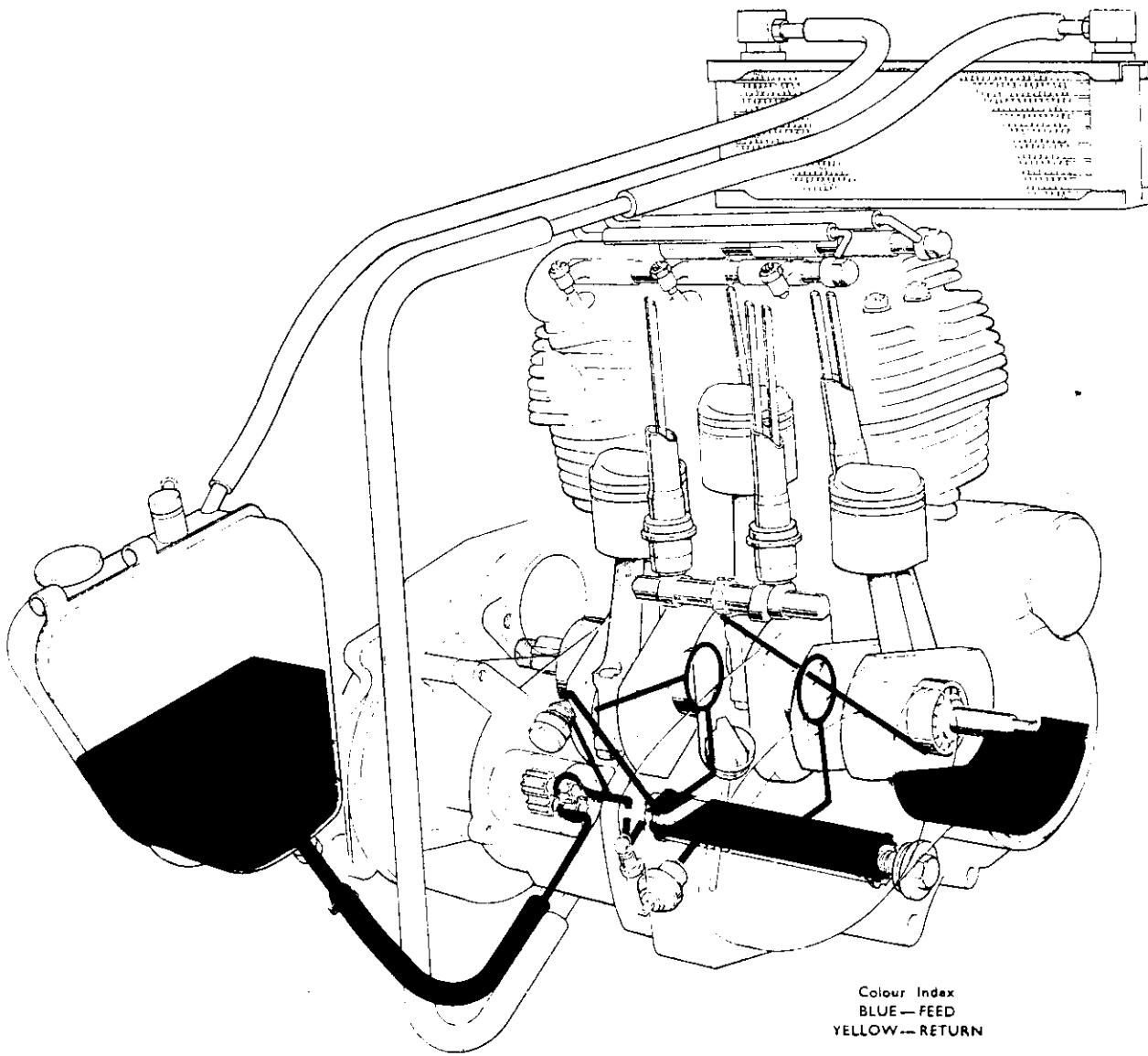


Fig. A2. Engine lubrication diagram

SECTION A2

FACTORY RECOMMENDED LUBRICANTS (All Markets)

UNIT	MOBIL	CASTROL	B.P.	ESSO	SHELL	TEXACO
Engine and Primary Chaincase	Mobiloil Super	Castrol GTX or Castrol XL 20/50	B.P. Super Visco-Static	Uniflo	Shell Super Motor Oil	Havoline Motor Oil 20W/50
Transmission (Gearbox)...	Mobilube GX 90	Castrol Hypoy	B.P. Gear Oil SAE 90 EP	Esso Gear Oil GX 90/140	Shell Spirax 90 EP	Multigear Lubricant EP 90
Telescopic Fork	Mobil ATF 210	Castrol T.Q.F.	B.P. Autron 'B'	Esso Glide	Shell Donax T.7	Texomatic 'F'
Wheel Bearings, Swinging Fork and Steering Races Speedometer Drive Unit.	Mobilgrease MS or Mobilgrease Super	Castrol LM Grease	B.P. L2	Esso Multipurpose Grease H	Shell Retinax A	Marfak All Purpose
Easing Rusted Parts ...	Mobil Handy Oil	Castrol Penetrating Oil	—	Esso Penetrating Oil	Shell Easing Oil	Graphited Penetrating Oil

The above lubricants were recommended for all operating temperatures above—18°C (0°F).

SECTION A3

ENGINE LUBRICATION SYSTEM

The engine lubrication system is of the dry sump type utilising a duplex gear pump and the oil is fed by gravity from the tank to the pump. Under pressure from the feed pump, oil is forced via a cartridge type filter through drillings in the crankshaft to the inner main bearings and big ends, whence it escapes and lubricates the cylinder walls, outer main bearings, and other internal engine parts. Oil is prevented from draining into the crankcase when the engine is stationary by means of an anti-drain valve situated behind the pump.

The oil pressure between the pump and the crankshaft is controlled by a release valve.

After lubricating the engine and primary transmission, the oil drains through a filter to the sump,

where it is returned by the scavenge pump via the oil cooler to the oil tank. The oil pump has been designed so that the scavenge gears have a greater pumping capacity than the feed gears, thus ensuring that the sump remains dry at all times.

The oil feed to the valve operating mechanism is taken from a connection situated between the scavenge side of the pump and the oil cooler. After lubricating the rocker spindles, the oil is fed into the rocker boxes by way of grooves in the rocker arms, afterwards draining down the push rod cover tubes and into the sump, whence it is subsequently scavenged. The timing idler pinion bearing is lubricated by oil draining through a drilling in the right side crankcase.

SECTION A4

CHANGING THE ENGINE OIL AND CLEANING THE FILTERS

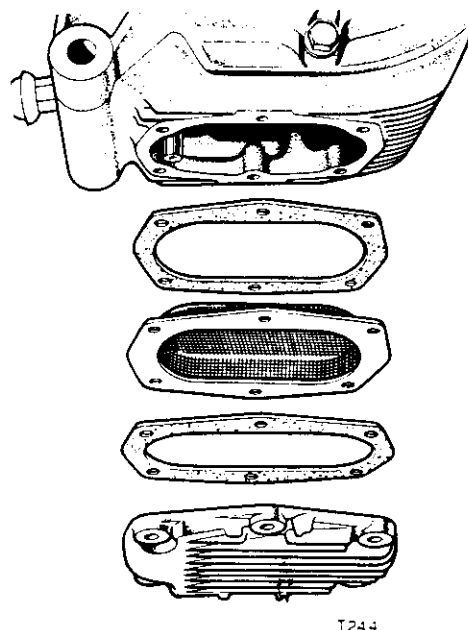
The oil in new and reconditioned engines should be changed at 250, 500 and 1,000 miles (400, 800 and 1,500 kms) intervals during the running-in period, and thereafter as stated in Section A1.

It is advisable to drain the oil when the engine is warm as it will flow more readily.

When the oil has been drained it is essential that the wire gauze filters are washed in paraffin (kerosene) and that the cartridge filter is replaced.

THE SUMP FILTER

Remove six nuts and locking washers which secure the sump plate, and remove the plate, two gaskets and wire gauze filter (see Fig. A3). Allow the sump to drain for approximately ten minutes. Clean the filter, and replace the gaskets. A gasket is fitted either side of the filter. Refit the sump plate, ensuring that the pocketed end is towards the rear of the engine.



T244

Fig. A3. Crankcase sump filter

THE OIL TANK

Open the twin seat and remove the tank filler cap. Place a tray below the drain plug, remove this and allow approximately ten minutes for the oil to drain. Disconnect the feed line union nut and unscrew the large hexagonal headed filter. Wash it thoroughly in clean kerosene (paraffin).

It is advisable to wash out the oil tank with flushing oil (obtainable from most garages) or, if this is not available kerosene (paraffin) will serve as a substitute. However, if this is used, ensure that all traces are removed from the interior of the tank prior to re-filling with oil. (For the correct grade of oil see Section A2).

NOTE: The level in the tank should be up to the top line on the dipstick. Further addition of oil will cause excessive venting through the breather pipe due to lack of air space.

THE FULL-FLOW FILTER

This filter is of the disposable type and should be renewed every 3,000 miles (5,000 Km) when the oil is changed.

To remove the filter, unscrew the large hexagonally headed cap from below the forward end of the

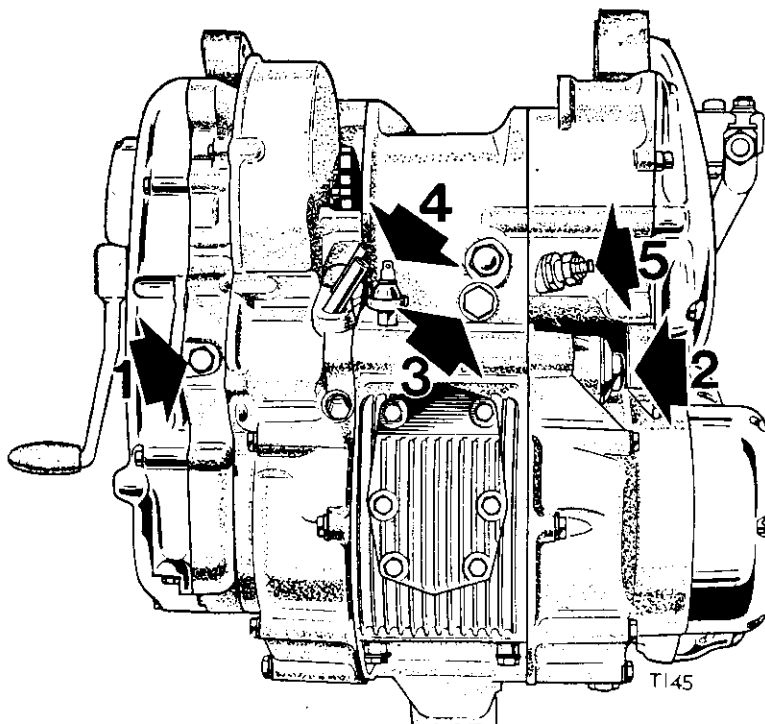
transmission outer cover (Item 2, Fig. A4). Remove the spring, and withdraw the element.

THE NEW ELEMENT MUST BE FITTED WITH THE OPEN END INWARDS, OTHERWISE THE OIL SUPPLY WILL BE CUT OFF.

A rubber sealing ring is located at the inner end of the element. Ensure that this is not omitted.

Add a small quantity of engine oil to the filter compartment before re-assembling the filter. Replace the spring and cap, ensuring that the 'O' ring seal is in good order. Replenish the oil tank to dip-stick level, and if, for any reason, the oil cooler has been removed, re-check and if necessary top-up the tank after approximately five miles.

Special Note: To ensure immediate lubrication of internal parts, following replacement of the filters, add half a pint of engine oil to the crankcase and operate the starter pedal twenty or thirty times (with the ignition switched off) until oil is seen issuing from the return pipe in the tank. The oil can be inserted through the spark timing plug aperture on the front of the crankcase at the right side and it will be necessary to allow sufficient space in the tank to accommodate this oil. This procedure should also be followed when the motor cycle has not been used for an appreciable time.



1. Primary chaincase drain plug
2. Cartridge oil filter housing cap
3. Gearbox drain and level plugs
4. Oil pressure switch
5. Neutral Indicator switch

Fig. A4. Transmission drain and filler plugs

SECTION A5

OIL PRESSURE

The oil pressure is controlled by means of the relief valve situated at the rear of the centre crankcase, on the left side (Fig. A5). When the engine is stationary there will be no oil pressure. On starting from cold, pressure may be as high as 90 lbs., p.s.i. temporarily, reducing, when hot, to the normal running figure of 75/90 lbs. p.s.i. at three thousand r.p.m.

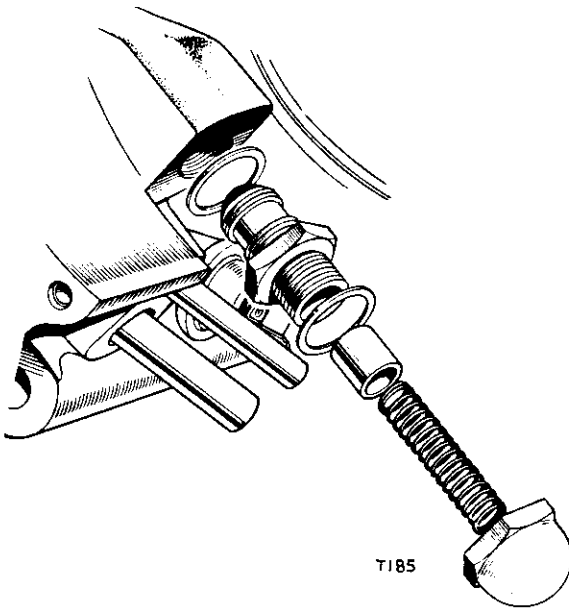


Fig. A5. The oil pressure relief valve

The pressure can only be checked with a gauge connected to an adaptor specially designed to replace one of the blanking plugs on the front of the centre crankcase (see Fig. B34).

If satisfactory readings are not obtained, check the following:—

- (1) That the oil pressure relief valve gauge is clean.
- (2) That the oil level is not below the minimum mark on the dipstick, and that oil is being returned to the tank.
- (3) That the sump filter, crankcase filter, and tank filter are clean and not blocked.
- (4) That the oil pump is functioning properly, and that there is a supply of oil to the pump. Refer to Section A7 for checking the oil pump.
- (5) That the drillings in the crankcase connecting the oil pipes to the oil pump are clear.
- (6) That the big ends and centre plain main bearings are not excessively worn. If the bearings have too great a working clearance, oil will escape more readily, particularly when warm, thus giving a reduced pressure.

Excessive periods of slow running (such as in heavy traffic), or unnecessary use of the air control, can cause dilution of the oil, and hence an overall drop in pressure, due to the lower viscosity of the diluted oil.

Most lubrication and oil pressure troubles can be avoided by regular attention to the recommended oil changes.

SECTION A6

THE OIL PRESSURE RELIEF VALVE

The oil pressure relief valve is very reliable and should require no maintenance other than cleaning of the gauge. It is situated on the underside of the engine to the rear of the oil pump housing. Oil pressure is governed by the single spring situated within the valve body, and if it is suspected that the spring is faulty, then the valve must be replaced as a unit.

The spring strength is designed to operate the valve at a pressure of 75-85 lb. psi. with the oil at normal running temperature.

Unless a special tool is available, access to the relief valve assembly can only be obtained by stripping the primary transmission (Section C). Service tool 60-2135 can be obtained to remove the relief valve after the flexible oil feed and scavenge pipes have been disconnected at the crankcase.

To prevent the loss of oil from the oil cooler and oil tank the ends of the pipes should be plugged as they are disconnected.

When the valve has been removed the hexagonal domed cap can be unscrewed from the main body, thus releasing the piston which should be withdrawn.

Thoroughly clean all parts in (kerosene) paraffin and inspect for wear. If any defect is apparent, e.g. scoring of piston, spring fracture, etc. the whole unit must be replaced. When screwing the relief valve unit into the crankcase, fit a new fibre washer between the body and the crankcase. (Figure A5).

SECTION A7

REMOVING AND REPLACING THE OIL PUMP

The oil pump (Fig. A6). is mounted in the drive side crankcase, protruding through the inner primary chaincase, and driven by a train of gears from the crankshaft. Since the moving parts continually operate in oil, the degree of wear should be very slight, though after considerable mileage, the pump may require renewal.

To gain access to the oil pump, remove the outer primary chaincase (Section C5) and the inner primary chaincase (Section C7). This will, of course, include removal of the oil pump drive gear. Remove the four 'cross-slot' screws holding the oil pump to the crankcase and the pump can be withdrawn. The remaining two slot headed screws serve to hold together the three portions of the oil pump body, and should not be disturbed.

Upon reassembly ensure that a new gasket is fitted between the oil pump and crankcase. Check that the oil pump is properly located over the dowel in the crankcase recess.

Having fitted the pump, do not over-tighten the 'cross-slot' screws, which are of small diameter, threaded into alloy. Fit a new 'O' ring seal into the recess surrounding the pump body.

Replace the transmission and chaincases as in Sections C5, C8, and C9.

Do not forget, when fitting the oil pump gear, to apply Loctite compound to the securing screw threads.

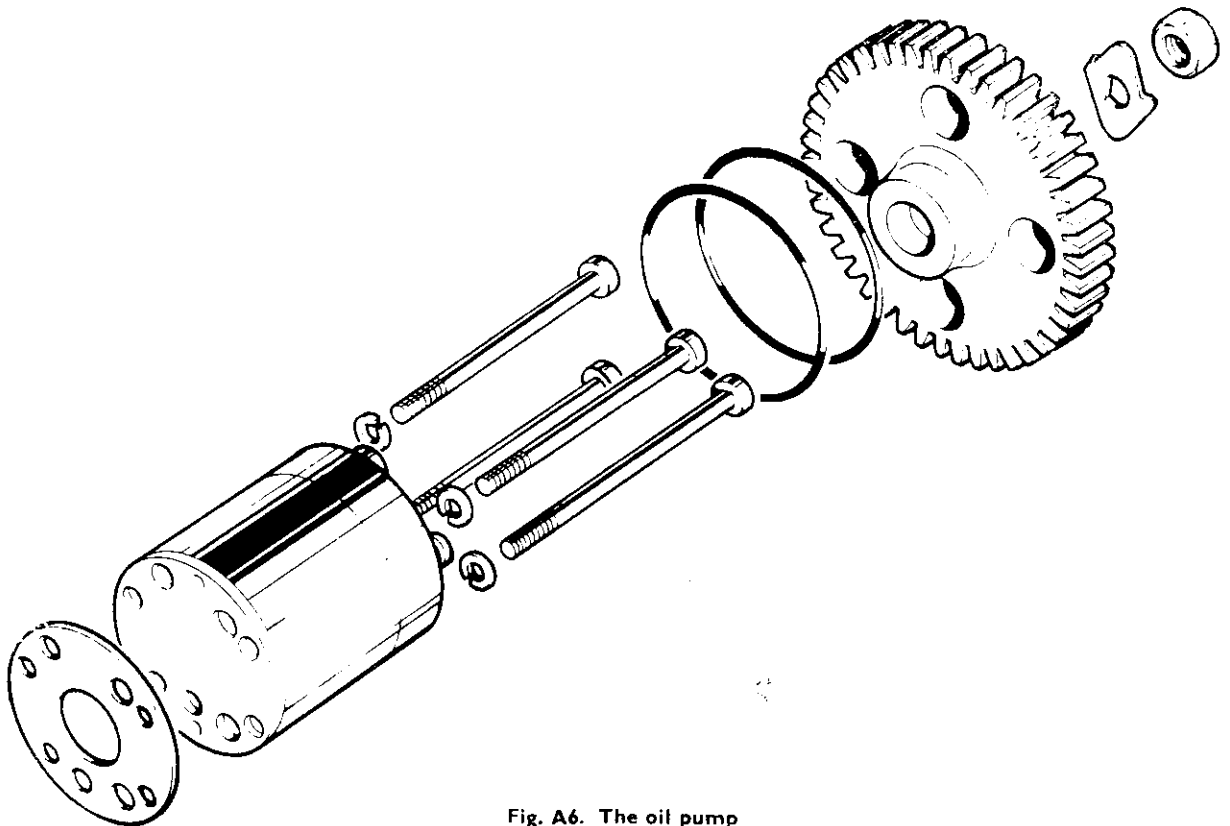


Fig. A6. The oil pump

SECTION A8

REMOVING AND REFITTING THE OIL COOLER

To gain access to the oil cooler, oil pipe clips, and fixings, the gas tank should be removed (Section E1).

Unscrew both oil pipe clips and note that the left hand pipe from the cooler leads to the rocker feed pipe. After removal of the pipes, ensure that the cooler is not tilted, since it contains over half a pint of oil.

Slacken two support bracket top bolts sufficiently to allow eight corner packings to be removed (Fig. A7).

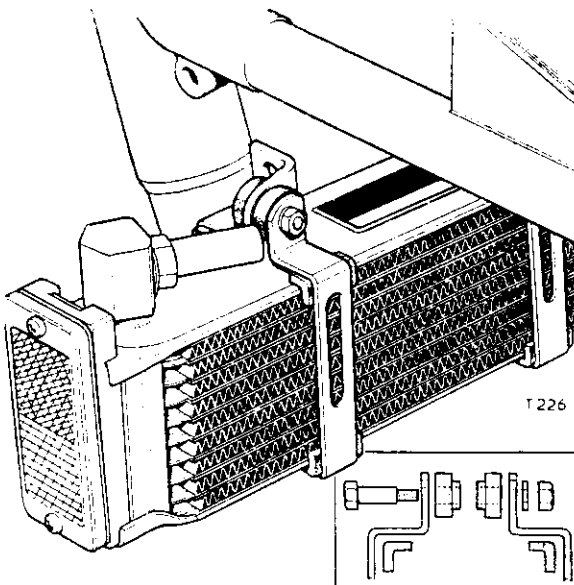


Fig. A7. Oil cooler mountings

Whilst supporting the cooler, remove the support bracket bolts, nuts and washers, and collect four spigotted rubber washers.

The cooler is now free of the frame and should be removed and drained by inverting above a suitable container.

Do not attempt to flush out the inside of the cooler, since little or no foreign matter is collected. However, it is advisable to wash the outside with kerosene (paraffin) and a soft brush.

To refit, assemble the support brackets as shown (Fig. A7), and note that the large oil pipe unions on the top of the cooler are inclined rearwards. Suspend the cooler on the frame using spigotted rubbers and bolts as shown (Fig. A7).

Secure both brackets to the frame, and replace both large diameter oil pipes. The left side union connects to the scavenge pipe, i.e. the pipe which connects to the metal rocker feed pipe union. Tighten the union clips ensuring that the pipes are not damaged by over tightening.

Refit the gas tank as in Section E1.

Note that where reflectors are fitted, their rubber backings are attached to the oil cooler by a suitable adhesive.

SECTION A9

REMOVING AND REPLACING THE ROCKER OIL FEED PIPES

To disconnect the rocker oil feed pipe for removal, the two domed nuts should be removed from the ends of the rocker spindle, and the banjos withdrawn. Disconnect the rocker oil feed pipe from the scavenge oil cooler pipe. Dismantle the flexible pipes and connections to the rocker spindle. Drain the pipes into an oil tray.

Care should be taken that the metal pipes are not bent excessively because this might ultimately result in a fracture. When removed, the feed pipes

should be thoroughly cleaned in kerosene (paraffin) and checked for blockage with the aid of a jet of compressed air.

When refitting the feed pipes, it is advisable to use new copper washers, but if the old ones are annealed they should give an effective oil seal. Annealing is achieved by heating to cherry red heat and plunging into water. Any scale that is formed on the washers should be removed prior to re-fitting them.

SECTION A10 ANTI-DRAIN VALVE

The anti-drain valve is situated in the crankcase centre section adjacent to the oil pump housing. The purpose of the valve is to prevent oil draining through from the feed side of the pump when the engine is stationary overnight, or when the pump has suffered a great deal of wear. If this condition is evident (indicated by voluminous smoke from the exhaust), it must be assumed that the ball of this valve is sticking, or is being held off its seating by some means. To clean the ball and spring, hold the cupped hand beneath the valve, remove the plug from the crankcase, and collect the ball and spring. (Fig. A8). Wash these carefully in kerosene (paraffin) and replace having made sure that the ball seating is free of foreign matter.

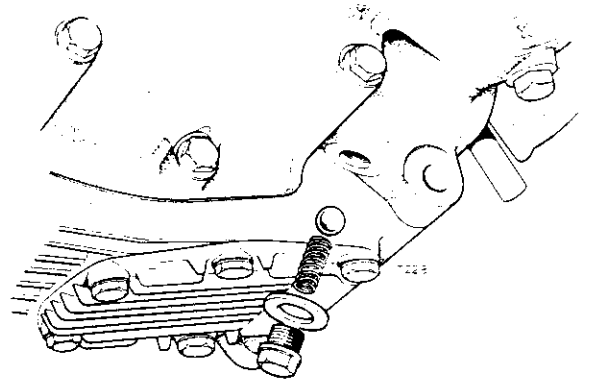


Fig. A8. Anti-drain valve

SECTION A11 CONTACT BREAKER LUBRICATION

The contact breaker is situated in the timing cover, and it is imperative that no oil from the engine lubrication system reaches the contact breaker chamber. For this purpose, there is an oil seal at the back of the contact breaker unit, pressed into the timing cover. However, slight lubrication of the cam spindle at the slot K and auto advance pivots L is necessary. Also lubricate the moving arm of the contact breakers at pivots J, with one spot of engine oil.

On initial assembly the three felt lubricating wicks are impregnated with Shell Retinax "A" grease, and at intervals of 3,000 miles, three drops of clean engine oil should be applied to each wick, in order to lubricate the cam and nylon heels. If this operation is not carried out, premature wear will occur on each of the nylon heels.

The cam spindle must be lubricated with one drop of clean engine oil at the same time. Similarly, one drop of oil must be applied to governor pivots "M" (Fig. A.9). Check that the governor weights move freely, and that if the cam "K" is turned by hand against the spring tension and then released, the weights are seen to open and close.

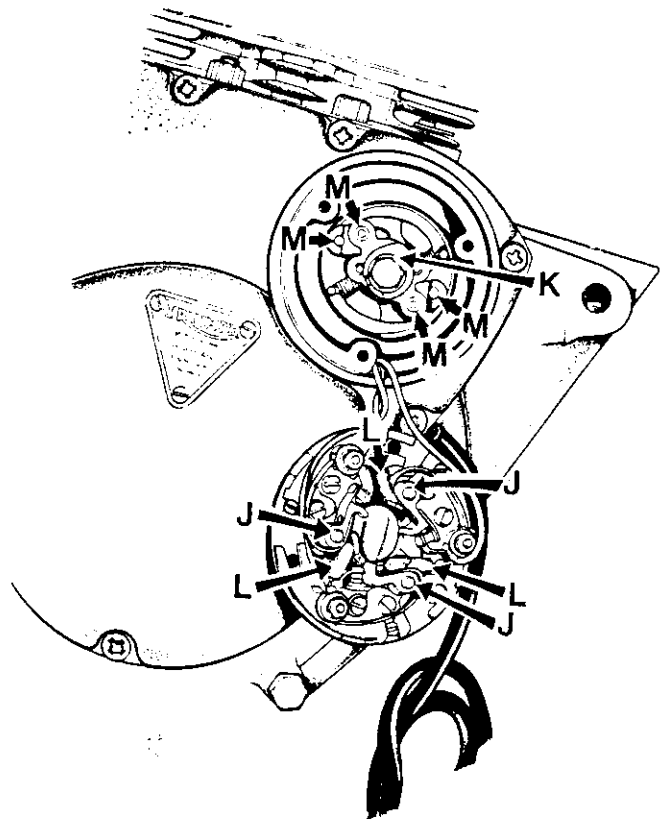


Fig. A9. Contact breaker lubrication points

SECTION A12

TRANSMISSION (GEARBOX) LUBRICATION

The transmission (gearbox) is lubricated by means of a self contained oil bath. Splash oil is fed to all gearbox components, including the enclosed gear-kickstarter mechanisms. The oil in the change and gearbox should be drained, and the gearbox flushed out, after the initial 500 miles (800 Km) running in period. Thereafter, the oil should be changed as stated in Section A1.

The oil can be drained by means of the plugs located underneath the transmission (gearbox), (Figure A10), preferably whilst the engine is warm, as the oil will flow more readily.

The filler plug and dipstick combined (T), is situated on top of the inner cover. When replenishing the oil, the drain plug must first be replaced and oil added to the transmission (gearbox) until it rises to the level shown on the dipstick **when this is screwed down**. In addition, the machine must be standing on level ground.

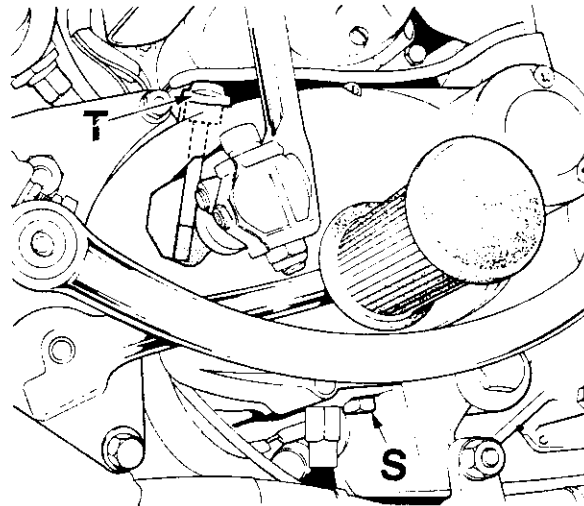


Fig. A10. Transmission (gear box) drain and filler plugs

SECTION A13

PRIMARY CHAINCASE LUBRICATION

The primary chain is lubricated by means of a self-contained oil bath, filled initially through the inspection cap (Fig. A11 item S) and thereafter the level is maintained by the engine lubrication system which "breathes" through the left side main bearing into the chaincase. The latter can be drained using the plug beneath the centre of the inner chaincase (Fig. A11 item X). Allow approximately ten minutes for draining and then replace the plug ensuring that the 'O' ring seal is serviceable. For initial filling, $\frac{3}{4}$ U.S. pint of 350cm³ of the correct grade of oil (see section A2 for recommended grade) should be used.

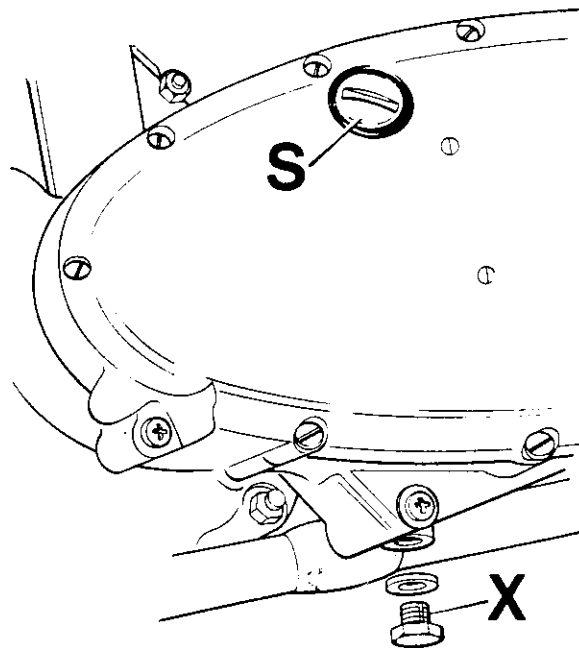


Fig. A11. Primary chaincase drain and level plugs

SECTION A14

REAR CHAIN LUBRICATION AND MAINTENANCE

On earlier editions, the rear chain feed is taken from a union situated in the neck of the oil tank (see Fig. A12). The rate of flow of oil to the chain can be controlled by means of a screw located in the and the screw should union be turned clockwise to reduce the flow and counter clockwise to increase it.

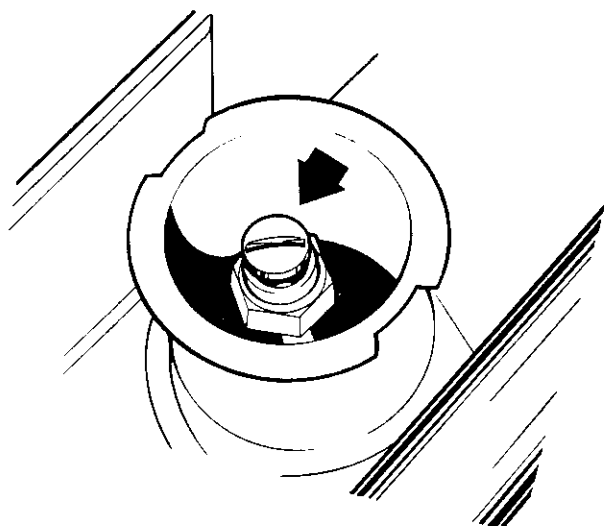


Fig A12. Rear chain oil feed adjustment

Disconnect the connecting link and remove the chain. If available, connect an old chain to the end of the chain being removed, and draw it on to the gearbox sprocket until the chain to be cleaned is clear of the machine and can be removed.

Remove all deposits of road dust etc. by means of a wire brush. Clean thoroughly in kerosene or paraffin and allow to drain.

Inspect the chain for excessive wear of the rollers and pivot pins and check that the elongation does not exceed $1\frac{1}{2}\%$. To do this first scribe two marks on a flat table exactly $12\frac{1}{2}$ inches (31,75 cm.) apart, place the chain opposite the two marks. When the chain is compressed to its minimum free length the marks should coincide with two pivot pins 20 links apart. When the chain is stretched to its maximum free length, the extension should not exceed $\frac{1}{4}$ in. (6,25 mm.). If it is required to remove a faulty link, or shorten the chain, reference should be made to Section C14.

To lubricate the chain, immerse it in MELTED grease (melt over a low flame, or, more safely, over a pan of boiling water) and allow it to remain in the grease for approximately 15 minutes, moving the chain occasionally to ensure penetration of the grease into the chain bearings. Allow the grease to cool, remove the chain from the bath and wipe off the surplus grease.

The chain is now ready for refitting to the machine.

NOTE: The connecting link retaining clip must be fitted with the nose-end facing in the direction of motion of the chain.

SECTION A15

GREASING THE STEERING HEAD BALL RACES

The steering head races are packed with grease on assembly, and require re-packing with the correct grade of grease at the interval stated in Section A1.

Removal and replacement of the bearing races is comprehensively covered in the front fork section.

When the races are removed, they should be cleaned in kerosene (paraffin), and the tapered surfaces should be cleaned likewise, then inspected for wear, cracking, or pooketing. If any of these faults are apparent, the whole bearing must be replaced.

Apply a fresh supply of grease to the races before reassembly.

SECTION A16

WHEEL BEARING LUBRICATION

The wheel bearings are packed with grease on assembly, but require re-packing with the correct grade of grease at the interval stated in Section A1.

The bearings on both the front wheel and rear wheel should be removed, cleaned in kerosene (paraffin), and assembled with the hubs well packed with the

correct grade of grease. For details concerning the grade of grease to be used (which is the same for both wheels), see Section A2.

Removing and replacing the bearings for the front and rear wheels is comprehensively covered in Sections F16 and F18.

SECTION A17

TELESCOPIC FORK LUBRICATION

The oil contained in the fork legs not only lubricates the bearing surfaces, but also acts as the damping medium. Because of the latter function, it is essential that the amount of oil in each fork leg is exactly the same quantity and of the correct viscosity.

Oil leakage midway up the forks usually indicates that an oil seal has failed and requires replacement; this is dealt with in Section G3.

Correct period for changing the oil is every 10,000 miles (16,000 km.), but some owners may not cover

this mileage in a year, in which case it is suggested that the oil be changed every 12 months.

To drain the oil, unscrew the fork cap nuts and the small drain plugs in the lower ends of the fork sliding members. Allow the oil to drain out then, whilst standing astride the machine, apply the front brake and depress the forks a few times, to drain any oil remaining in the system.

Replace the drain plugs, and pour 210 cm³ of oil into each fork leg, (see Section A2 for recommended grades of oil), and replace the cap nuts.

SECTION A18

LUBRICATION NIPPLES

The speedometer drive unit and the swinging fork pivot bearings are greased by means of lubrication nipples.

Care should be taken that the surface of the nipple is not damaged. Slight distortion may be removed with a fine grade file.

SWINGING FORK PIVOT

The greasing nipple (Fig. A13) is situated centrally underneath the swinging fork, and should be given several strokes with a high pressure grease gun at intervals, as specified on page A5, until grease is forced through each end of the pivot bearings.

If the grease does not penetrate then the pivot must be removed to ensure adequate lubrication. Removal of the swinging fork is detailed in Section E9. When the fork is removed the sleeves and distance tube should be withdrawn and all parts should be thoroughly cleaned out in kerosene (paraffin) and allowed to drain.

When re-assembling, the space surrounding the distance tube should be carefully packed with the correct grade of grease, and the sleeves should be well greased on their bearing surfaces.

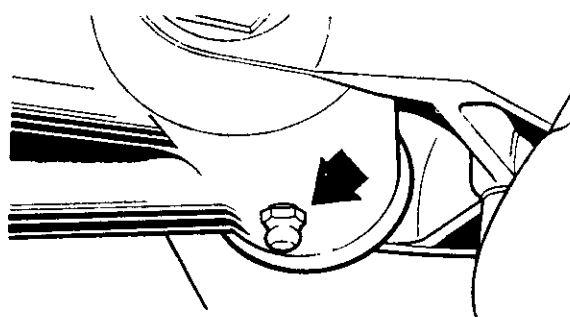


Fig. A13. Swinging fork pivot lubrication nipple

THE SPEEDOMETER DRIVE UNIT

It is preferable to use a hand grease gun for this item, when two strokes of the gun should be given, at intervals as specified on page A.5.

SECTION A19

LUBRICATING THE CONTROL CABLES

The control cables can be periodically lubricated at the exposed joint with a light grade of oil (see Section A2).

A more thorough method of lubrication is that of feeding oil into one end of the cable by means of a reservoir. For this, the cable can be either disconnected at the handlebar end only, or completely removed.

The disconnected end of the cable should be threaded through a thin rubber stopper and the stopper pressed into a suitable narrow necked can with a hole in its base. If the can is then inverted and the lubricating oil poured into it through the hole, the oil will trickle down between the outer and inner cables. It is best to leave the cable in this position overnight to ensure adequate lubrication.

SECTION A20

SPEEDOMETER AND TACHOMETER CABLE LUBRICATION

The speedometer and tachometer cables should be lubricated by means of grease (see Section A2 for correct grade). It is not necessary to remove the cables completely, but only to disconnect them from the instruments, and withdraw the inner cables. Unscrew the union nuts at the base of both speedometer and tachometer, withdraw the inner cables, and clean in kerosene (paraffin). Smear the surfaces with grease except for six inches (15 cm) nearest

to the speedometer and tachometer heads. The cables are now ready to be inserted into the outer casings and excess grease wiped off. Care should be taken that the "squared" ends of the inner cables are located in their respective "square" housings before the union nuts are tightened, and that the 'spade' end of the tachometer cable is correctly located in its driving tongue.

SECTION A21

BRAKE PEDAL SPINDLE LUBRICATION

The brake pedal spindle is carried in a boss, which forms part of the rear engine mounting plate, and should be lubricated at intervals with oil.

For this purpose, a small hole is drilled in the boss and, preferably, the oil should be applied from a pressure oil can.

SECTION A22

CHANGING THE FLUID IN THE BRAKING SYSTEM

It is advisable to drain all the hydraulic fluid from both front and rear braking systems at intervals of 12000 miles.

The reservoir and pipe lines will readily be emptied if the bleed nipple on the caliper unit, A, Fig. A14 is first fitted with a flexible tube and then slackened. The brake lever is then operated as many times as may be necessary to pump the fluid into a container. This method should be adopted in order to avoid spillage of fluid on to such items as brake pads, discs, tires, etc.

Disconnect the pipe line at the caliper unit, making sure that any oil draining from the pipe falls clear of the brake components, and remove the complete caliper unit. Drain out any oil remaining inside and if necessary, prise the pistons apart by means of a wooden wedge, to drive out the fluid.

Replenish the caliper unit with the correct type of fluid (see section F6) and reassemble to the machine. Refill the reservoir and the pipe line with the same fluid.

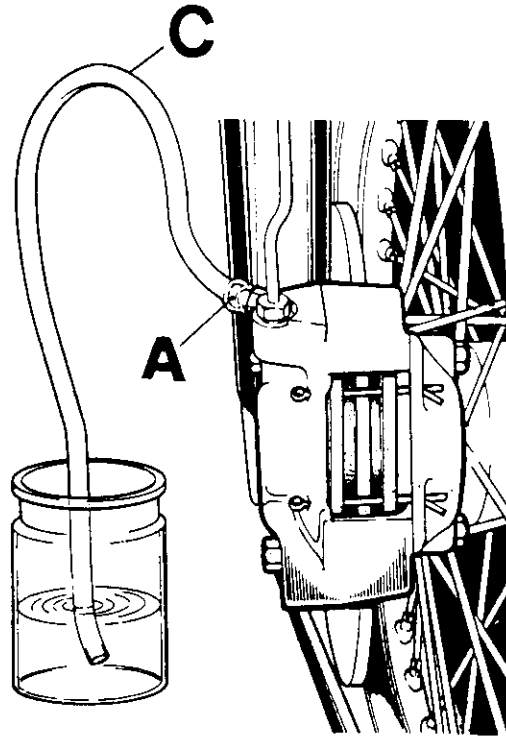


Fig. A14. Draining hydraulic system

AIR BUBBLES IN THE FLUID WILL CAUSE DANGEROUSLY INEFFICIENT BRAKES AND THESE MUST BE EXCLUDED BY A PROCESS KNOWN AS 'BLEEDING' THE BRAKE. THIS IS, THEREFORE, A VITAL OPERATION AND IS FULLY DESCRIBED IN SECTION F7 and F8.

SECTION B

ENGINE

DESCRIPTION	Section
REMOVING AND REPLACING THE ENGINE UNIT	B1
REMOVING AND REPLACING THE ROCKER BOXES	B2
INSPECTING THE PUSH RODS	B3
STRIPPING AND REASSEMBLING THE ROCKER BOXES	B4
ADJUSTING THE VALVE ROCKER CLEARANCES	B5
REMOVING AND REPLACING THE AIR CLEANER	B6
CARBURETOR—DESCRIPTION	B7
REMOVING AND REPLACING THE CARBURETORS	B8
STRIPPING AND REASSEMBLING THE CARBURETORS	B9
INSPECTING THE CARBURETOR COMPONENTS	B10
RESETTING THE CARBURETORS	B11
REMOVING AND REFITTING THE CYLINDER HEAD ASSEMBLY	B12
REMOVING AND REPLACING THE VALVES	B13
RENEWING THE VALVE GUIDES	B14
DECARBONISING	B15
RE-SEATING THE VALVES	B16
REMOVING AND REPLACING THE CYLINDER BLOCK AND TAPPETS	B17
INSPECTING THE CAM FOLLOWERS	B18
INSPECTING THE TAPPET GUIDE BLOCKS	B19
REMOVING AND REFITTING THE PISTONS	B20
REMOVING AND REPLACING THE PISTON RINGS	B21
INSPECTING THE PISTONS AND CYLINDER BORES	B22
TABLE OF SUITABLE REBORE SIZES	B23
REMOVING AND REPLACING THE CONTACT BREAKER	B24
ADJUSTING THE CONTACT BREAKER POINTS	B25
SPARK TIMING—STATIC	B26
SPARK TIMING BY STROBOSCOPE	B27
REMOVING AND REPLACING THE TIMING COVER	B28
EXTRACTING AND REFITTING THE VALVE TIMING PINIONS	B29
VALVE TIMING	B30
DISMANTLING AND REASSEMBLING THE CRANKCASE ASSEMBLY	B31
SERVICING THE CRANKSHAFT	B32
REFITTING THE CONNECTING RODS	B33
INSPECTING THE CRANKCASE COMPONENTS	B34
RENEWING THE MAIN BEARINGS	B35
REMOVING AND REFITTING TACHOMETER DRIVE	B36

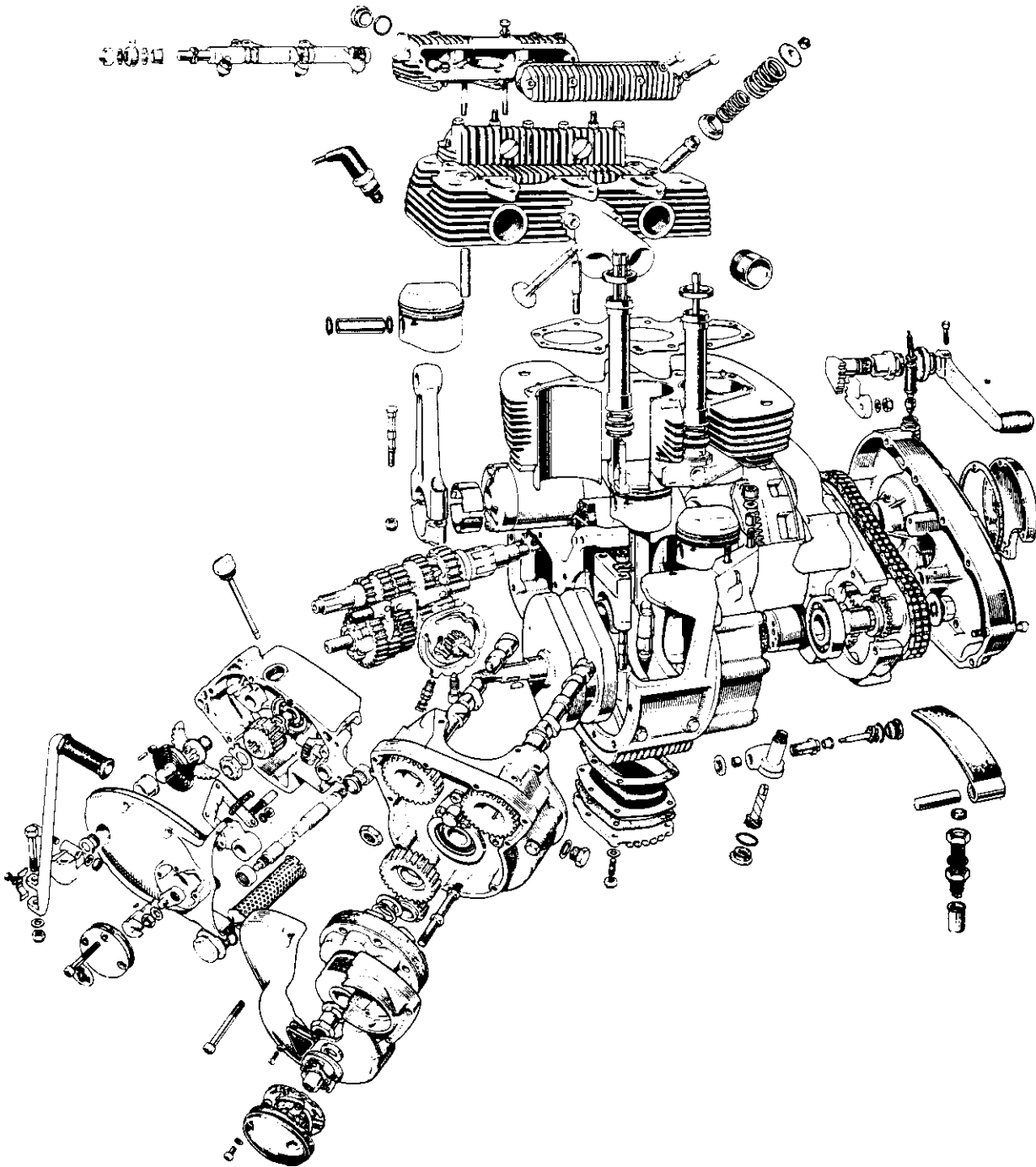


Fig. B1. Exploded view of the Trident engine-transmission unit

DESCRIPTION

The inclined engine is of unit construction, having three cylinders, a 120 degree crankshaft, and three aluminium alloy mating crankcase sections. The transmission housing is an integral part of the centre crankcase, and the clutch and primary transmission are housed in separate cases, bolted on to the main crankcase sections.

The aluminium alloy cylinder head has cast-in Austenitic valve seat inserts, and houses the overhead valves, which are operated by rocker arms housed in detachable alloy rocker boxes. Six aluminium push rods operate the rocker arms, which are each fitted with adjusters, accessible when the rocker box covers are removed.

The aluminium alloy die cast pistons each have two compression rings and one oil scraper ring. The connecting rods are of H Section RR56 alloy, with detachable end caps. These incorporate steel backed renewable "shell" type bearings. Each of the connecting rod caps is machined from a steel stamping and held in position by means of two high tensile steel bolts, which are tightened to a predetermined extension figure, to give the correct working clearance for the bearing on the crankshaft journals.

The inlet and exhaust camshafts are fitted transversely in the upper part of the crankcase, and are driven by a train of timing gears from the right side of the crankshaft. One end of the exhaust camshaft drives the adjustable contact breaker which is fitted with an automatic advance and retard mechanism, and the opposite end drives the tachometer cable.

The three-throw one piece crankshaft is supported by two "shell" type bearings, a roller bearing at the right side, and a ball bearing at the left side. The two plain inner main bearings are each retained by an alloy cap held by studs and self locking nuts, which are tightened to a predetermined torque setting.

The big-end bearings and the two inner main bearings are lubricated under pressure by oil which flows through drillings in the crankcase and crankshaft, from the double gear oil pump. Oil pressure in the lubrication system is governed by means of a relief valve, which is situated at the rear of the engine behind the inner primary chaincase cover.

The aluminium alloy cylinder barrel is fitted with Austenitic iron liners, and houses the pressed-in aluminium alloy tappet guide blocks. Power from the engine is transmitted through the engine sprocket and primary chain to the shock absorber unit, diaphragm clutch, and five speed constant mesh transmission. Primary chain adjustment is given by a pivoted rubber lined tensioner, which is immersed in the primary chain oil bath.

The electrical generator set consists of a rotor which is fitted to the right end of the crankshaft and a six coil stator which is mounted on three pillar bolts inside the timing cover. A starter motor and solenoid are mounted on the crankcase behind the cylinder block, the motor pinion engaging with a gear ring pressed on to the clutch body.

Carburation is by three Amal type 626 concentric carburettors with a common linkage.

SECTION B1

REMOVING AND REPLACING THE ENGINE UNIT

Open the twinseat, remove the large screw securing the left side battery cover, and pull the panel off the two locating pegs on the rear frame. Disconnect the fuse holder, which is fitted in the negative lead from the battery, and remove the petrol tank (Section E1). Take off the leads from the spark plugs. Remove the oil cooler (Section A8), and disconnect the rocker feed pipe by removing the two domed nuts from the right side of the rocker boxes. Slide the banjo connections over the rocker spindles, retaining the four copper washers. Take off the ground connections, which are attached to long engine studs, on top of the unit. It is advisable, at this stage, to remove the small right side panel, located in front of the oil tank, to prevent damage. This is held in position by three cross-head screws. Unscrew the oil tank drain plug, and allow the oil to drain into a suitable receptacle. Remove the oil cartridge filter end plug from beneath the front of the gearbox outer cover, and allow the compartment to drain. Unscrew two clips retaining the oil pipes to the crankcase stubs, and withdraw both pipes, allowing any oil to drain into a suitable container. The oil pipe stubs are situated beneath the left side of the centre crankcase section. Remove the gearbox drain plug from below the centre crankcase section, and allow the oil to drain into a suitable container. Refer to Fig. A6 for the position of the drain plug. The chaincase drain plug should be removed, and the chaincase allowed to drain. The drain plug is situated below the centre of the inner chaincase. Disconnect the tachometer cable from its drive box, located at the front left side of the crankcase.

Remove five cross head screws from the clutch release mechanism inspection cover. The cover can then be removed, and the cable detached from the mechanism. The most satisfactory method of disconnecting the clutch cable is to slacken the lock nut and adjuster on the centre clutch pull rod, thereby producing the required amount of slack in the cable. The nipple can then be removed from the slotted roller. Retain the cable abutment as the cable is withdrawn. The carburetors and air cleaner body can be taken off as one unit. First, release the screw at the end of the air cleaner container, on the right side. This will allow the outer cover and filter element of the air cleaner to be removed. The throttle cable should be removed from the

carburetor linkage by first unscrewing the adjuster, and withdrawing the cable from the cable stop. The nipple can be removed from the throttle by turning it through 90 degrees, and sliding the cable and the nipple out of the lever sideways. Slacken the six worm drive clips securing the inlet manifold connection hoses, and also remove the rubber buffer from the bottom air filter support lug. The rubber is just a push-in fit in the casting. Remove the air filter to crankcase breather pipe, when the whole assembly can be pulled off the connection hoses, and withdrawn from the left side of the machine, complete with choke operating lever and cables.

Disconnect the two stator snap connectors (Green/White and Green/Yellow), which are located at the rear of the engine unit, above the transmission (gearbox). Then disconnect the three contact breaker snap connectors (Yellow/Black, White/Black, and Red/Black), situated at the top, front, of the oil tank, beneath the twinseat.

Next, take off the silencers, which are held by two bolts to a bracket on either side of the machine, and by a clip at their forward end. Slacken the exhaust pipe clips on the two outer pipes, and also the clips at the joints between the four pipes and the collector box. The tie bolt for the inner exhaust pipes can then be taken off, which should enable the complete assembly to be removed as a unit. Disconnect the oil pressure switch wire, the switch being located to the right of the oil pipe stubs beneath the crankcase, and also the neutral indicator switch wires, at the snap connectors, in the same vicinity. Disconnect the two wires from the footbrake stoplight switch, mounted on the right side engine plate. Withdraw the oil tank breather pipe from its hollow stub on the chaincase vent chamber inspection cover. Remove the rear chain split link, and take off the chain.

Take off the left side engine plate, complete with footrest, by removing four bolts and nuts, with distance spacers etc., and one bolt in the middle of the plate. Remove the bolts holding the right side engine plate and footrest. It will be found that the bottom one of the two bolts holding the engine itself will not withdraw completely, being restricted by the footbrake pedal, but it must be withdrawn as far as possible. Note that a ground (earth) cable

connection is located under the nut of the top bolt. It is most essential that this connection is replaced on re-assembly using a new self locking nut. The small nut and bolt, holding the brake fluid pipe to the engine plate, should also be removed. Unscrew and take off the forward adjuster nut on the rear brake pinch rod. This will enable the engine plate, complete with footrest, brake pedal and operating lever, to be lifted clear of the brake operating mechanism and the frame.

To remove the long engine securing bolt from beneath the crankcase, take off the nut and spring washer at the left end, and withdraw the bolt from the right side. Note that on the right side there is a spacer fitted between the crankcase and the frame tube. Disconnect the horn, then remove it from the left front engine bracket. Take off the nut and washer from the left end of the front engine securing stud, and withdraw the stud, also remove the bottom of the two bolts holding the left front engine bracket to the frame. Slacken the top bolt, when the bracket can be swung to one side, as shown in Fig. B2. The bolt can then be slightly tightened to hold the bracket in this position. The engine unit is now ready to be lifted from the frame, but owing to the weight of the unit, (180 lbs. approximately), it is advisable to employ the use of two lifting bars, which can be located one in the front engine mounting lug, and one in the top rear left side engine plate mounting lug (Fig. B2). This

operation will require two people, situated at either side of the crankcase. The most satisfactory method of removing the engine is to raise it and turn the unit counter-clockwise, while viewed from the top of the machine, in order to clear the front crankcase lug. The unit will then lift out to the left side.

REPLACING THE UNIT

To replace the complete engine unit, it should be lifted into the frame again, (utilising the two lifting bars in the same positions as for the removal), transmission (gearbox) first, from the left side. The front of the unit can then be swung round into position. Replace the bottom mounting stud, from the right side, ensuring that the spacer is fitted in the correct position, between the crankcase lug and the bottom frame tube, on the right side of the machine. Replace the nut and spring washer.

Slacken the top bolt, holding the left front engine plate, and swivel the plate round, so that the appropriate hole lines up with the hole in the crankcase lug, then replace the stud, washer, and nut. Replace the bottom bolt, and tighten both that and the top one. Replace the left side rear engine plate, ensuring that the two spacers are refitted between the rear crankcase lugs and the engine plate. Refit the remaining bolts, washers, and self locking nuts, and the large swinging arm lug bolt and thick plain washer. Replace the right side engine plate, carefully engaging the brake operating lever with the brake rod, and replacing the adjusting screw. Secure the plate with the bolts, washers, and self locking nuts, and the large central collar nut. Slide the air filter to clutch cover rubber pipe over the crankcase sleeve, and connect both the stator and contact breaker leads (colour to colour).

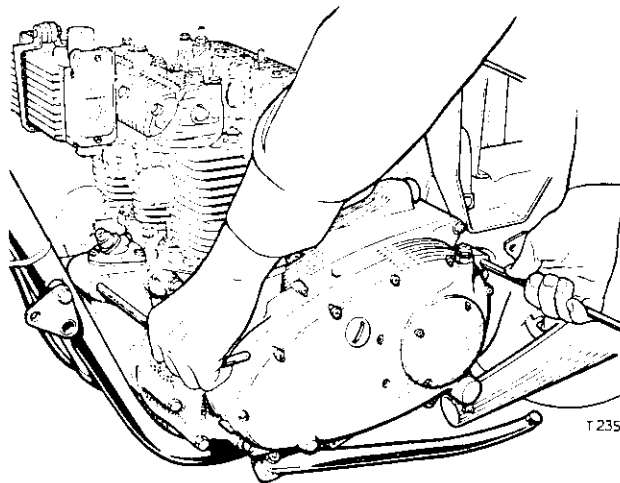


Fig. B2. Location of engine lifting bars is identical procedure for that of T160 Model

Refit the chain over the transmission (gearbox) sprocket, and over the rear wheel sprocket. Fit the split link, ensuring that the closed end of the link is to the front end of the machine when positioned on the top run of the chain. If any difficulty is experienced in refitting the chain, remove the rear wheel, (Section F5), engage top gear, offer the chain to the top of the sprocket, and, with the aid of a second operator using the kickstart, slowly wind the chain over the sprocket. Reconnect the oil pipes under the engine, and tighten the securing clips. Ensure that the oil feed pipe from the bottom of the oil tank leads to the top small stub below the crankcase. The oil pipe from the larger bottom stub connects to the rocker

B

ENGINE

feed pipe. The pipe from the front of the rocker feed connection leads to the left side of the oil cooler, and the right side pipe from the oil cooler connects to the return union at the front of the oil tank.

From this point, reassembly is mainly a reversal of the dismantling procedure, but there are one or two particular items to note. Do make sure that the H.T. coils are connected to the correct cylinders. The left side coil (Black/Yellow lead) feeds the left side cylinder, the middle coil (Black/Red lead) the middle cylinder, and the right side coil (Black/White lead), the right side cylinder. When refitting the carburetor assembly, make sure that the air cleaner element is fitted the right way round, as mentioned in Section B6. Remember to remake all

electrical connections. Take particular care, when refitting the exhaust assembly, to ensure that all the joints are correctly made. If an air leak takes place at one of these joints, it may result in a tendency for the machine to backfire on the overrun, which may, in turn, lead to silencer damage. Make sure that the four copper washers are in their correct positions when replacing the rocker feed pipes at the rocker spindles. Finally, make sure that all oil levels are correct, (see also Section A.2), bearing in mind that half a pint less than normal should be added to the oil tank, to allow for the half pint added to the sump, (as mentioned in Section A.4). The engine should then be turned over with the kickstart pedal until oil is seen to be returning to the oil tank, thus ensuring that the unit is fully lubricated, and ready for starting.

SECTION B2

REMOVING AND REPLACING ROCKER BOXES

Open the twinseat and remove the screw securing the left side panel, and withdraw it from two locating pegs on the rear frame. Disconnect the fuse from the negative lead from the battery, turn both fuel taps off, and remove the fuel tank (Section E1). Take off the ground (earth) leads from the extended studs and then the tachometer cable retaining loop. Remove the domed nuts securing the rocker feed pipes. Withdraw the feed pipes from both rocker spindles, and retain the four copper washers. If these are to be used again, they should first be annealed by heating to a dull red color and plunged into cold water. Disconnect the three high tension leads, and to avoid possible damage at a later stage remove all three sparking plugs.

Remove four bolts and plain washers, from each rocker box inspection cover, and withdraw both covers. If any difficulty is experienced light taps from a hide faced mallet should effectively remove these covers. Remove three socket head screws from inside each rocker box, followed by the end bolts (outside). Unscrew the eight rocker box bolts starting from the centre, noting their positions because of their varying lengths (including the extended studs) and lift both rocker boxes away from the cylinder head. Remove the six push rods and four push rod cover tubes together with their bottom cups and seals.

Keep careful note of the location of each push rod, which must be replaced in the same position as when removed.

Remove the securing bolts in the reverse order to that shown in Fig. B12, i.e. slacken the highest number first.

When refitting, ensure that the joint surfaces of both the rocker boxes and cylinder head are clean. Lightly grease the new rocker box gaskets, and position these on the cylinder head. Refit the four push rod tubes, ensuring that the cups are refitted the correct way up (see Fig. B3) and that new seals are fitted at both the top and bottom of each tube together with new gaskets below the bottom cups.

Refit the push rods, two in each right side tube, and one in each left side tube in the same position as they were originally fitted. Remove the two inspection covers from the inlet rocker box, and lower the rocker box onto the cylinder head. Each push rod can be located on to its respective rocker arm with the aid of a pair of thin nosed pliers. Ensure that the push rod tube and oil seal are positioned correctly in their recesses in the rocker box.

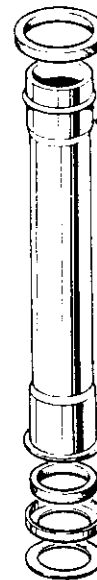


Fig. B3. Arrangement of push rod tube seals

Refit the four rocker box bolts and plain washers, ensuring that the two shorter bolts are fitted in the centremost holes. Lightly tighten these bolts, and refit three socket head screws, and two end bolts and plain washers.

Repeat this procedure for the exhaust rocker box and when assembled tighten the rocker box and cylinder head bolts in the sequence shown (Fig. B12). The correct torque figure is given in the GENERAL DATA, page GD 7.

Following re-assembly of the remaining items the valve-rocker clearances should be adjusted (Section B5).

SECTION B3

INSPECTING THE PUSHRODS

When the pushrods have been removed, examine them for worn, chipped or loose end-cups; also check that the push rod is true by rolling it slowly on a truly flat surface (such as piece of plate glass).

Bent pushrods are found to be the cause of excessive mechanical noise and loss of power and should be straightened if possible, or, preferably, renewed.

SECTION B4

STRIPPING AND REASSEMBLING THE ROCKER BOXES

Removal of the rocker spindles from the rocker boxes is best achieved by driving them out, using a soft metal drift. When the spindles are removed, the rocker arms and washers can be withdrawn. All parts should be thoroughly cleaned in kerosene, (paraffin), and the oilways in the spindles should be cleaned with a jet of compressed air.

Remove the 'O' rings from the rocker spindles and renew them.

If it is required to renew the rocker ball pins, the old ones should be removed by means of a suitable drift. New ones should then be pressed in.

To ensure an oil-tight seal between the rocker box and cylinder head, in cases where an oil leak cannot be cured by fitting new gaskets, the joint surface of the rocker box should be finished to remove any irregularities.

An effective finish can be achieved by lightly rubbing the junction surface on a sheet of emery cloth

mounted on a truly flat surface (such as a piece of plate glass).

The following method of assembly incorporates the use of a home made alignment bar, which can be made from a $\frac{7}{16}$ in. dia. bar \times $9\frac{1}{2}$ in. long by grinding a taper at one end.

Smear the plain washers with grease and place them against the cast bosses or rocker arms as shown in Fig. B5.

Commencing from the left end of each rocker box (i.e. end with larger hole), fit the rocker arms. Compress each Thackery washer (double-coil) with thin nosed pliers and assemble these. Align each rocker in turn with the alignment bar. When all the arms and washers are correctly aligned, remove the bar.

Lubricate the spindle with engine oil, and slide it, complete with 'O' ring, through the ring compressor tool 60-2221 (Fig. B4) and as far as possible into the rocker box. Finally tap it home with a hammer and soft metal drift, and remove the tool.

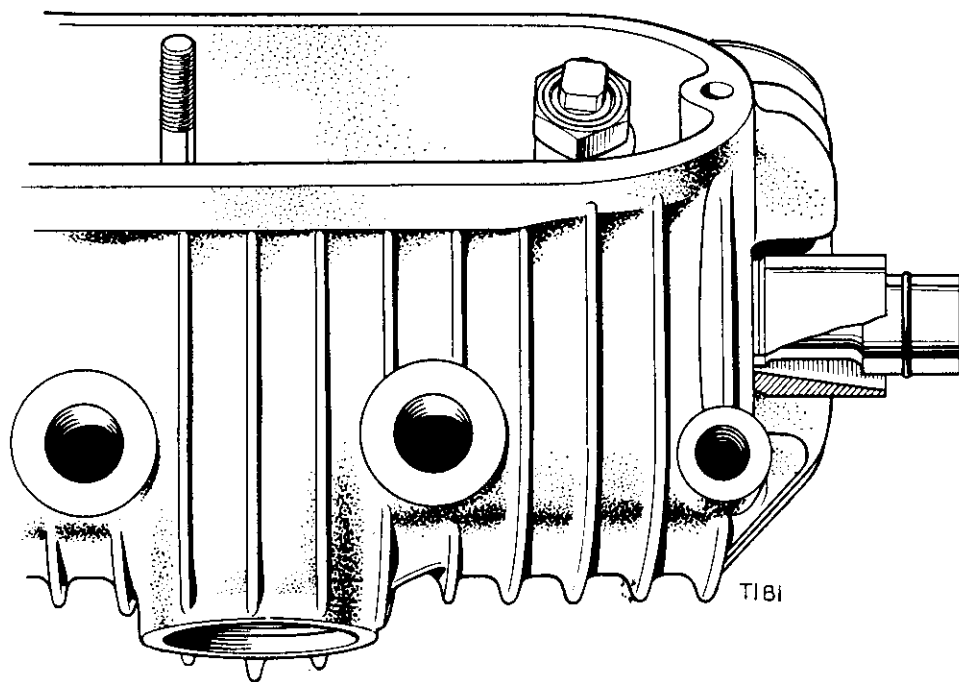
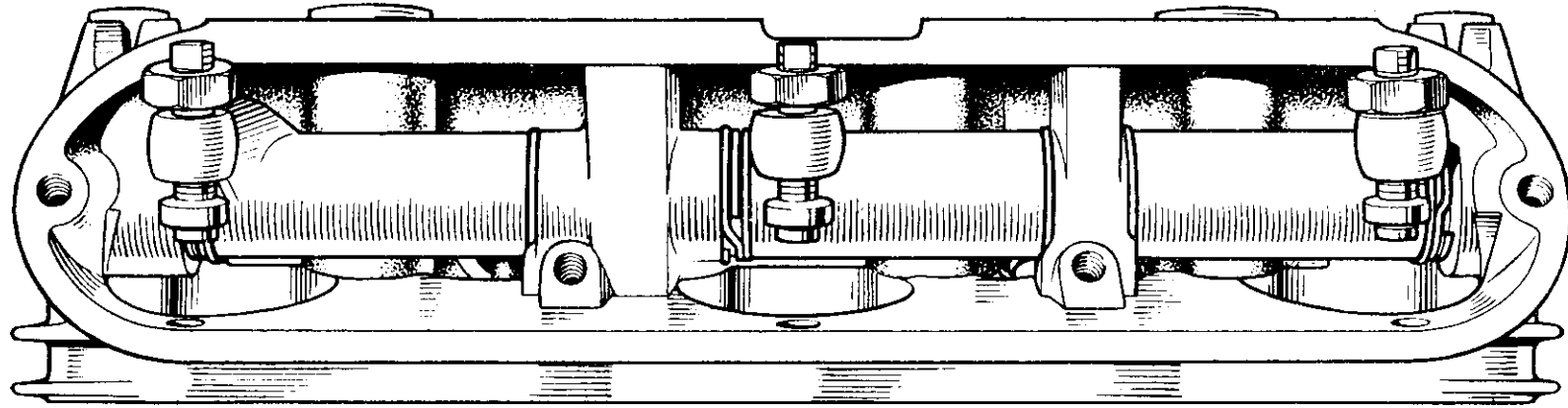
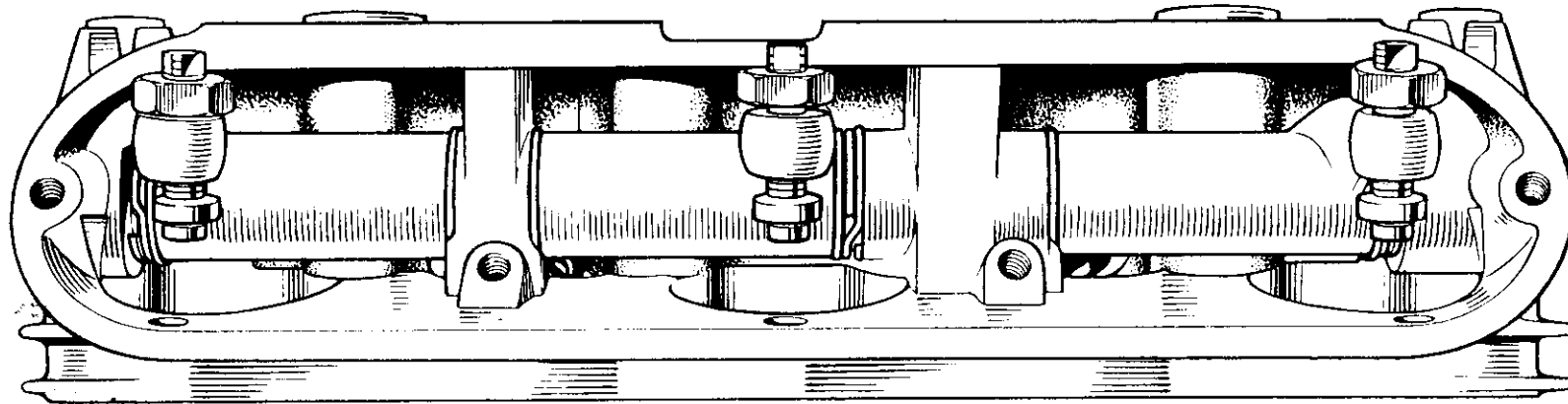


Fig. B4. Refitting rocker spindle using service tool 60-2221

B10



INLET



T179

EXHAUST

Fig. B5. Arrangement of rocker arms and washers

SECTION B5

ADJUSTING THE VALVE ROCKER CLEARANCES

The valve rocker clearances should be checked and if necessary, adjusted every 3,000 miles (5,000 Km). The correct clearance for the type of camshaft employed, ensures that a high valve operating efficiency is maintained, and that the valves attain their maximum useful life.

NOTE: Adjustment should only be made when the engine is cold.

Access to the rocker arm adjuster screws and locknuts is obtained by removing both the inlet and exhaust rocker inspection covers. These are retained by four bolts and plain washers.

Adjustment is carried out with a ring spanners (.5" AF) and an open end spanner (.25" AF).

Disconnect the H.T. leads and remove the spark plugs. This will enable the engine to be turned easily without resistance due to compression. Set the machine on its centerstand, select top gear, and position the crankshaft (and hence the rockers) by turning the rear wheel.

Commencing with the inlet rockers, turn the engine until any two rocker arms are "on the rock".

This is a condition whereby the two corresponding valves are open by equal amounts. In this case it will be approximately $\frac{1}{8}$ in. One valve is almost closed, and the other is just opening (see Fig. B6).

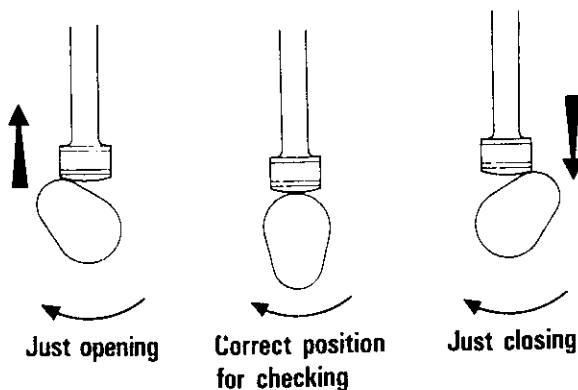


Fig. B6. Position of camshaft for valve setting

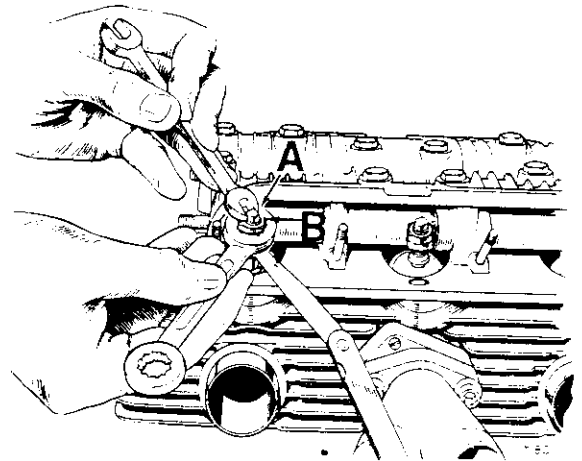


Fig. B7. Adjusting valve rocker clearances

At this stage the third valve is in the correct position for setting.

The correct rocker clearances are:

Inlet 0.006 in.

Exhaust 0.008 in.

Referring to Fig. B7, to adjust the clearance, slacken the locknut B and **unscrew** the adjuster A by a small amount, e.g. half a turn. Insert a feeler gauge of the correct thickness between the adjuster screw and the valve stem, and screw down the adjuster until it lightly pinches the gauge. Hold the adjuster at this position with a wrench, tighten the locknut, and withdraw the gauge.

Adjust the remaining clearances in a similar manner.

Note: Before commencing the above operation, it is advisable to give the end of the adjuster screw a light tap to make sure that the ball is properly seated in the screw.

Replace the inspection covers, renewing the gaskets if any damage is evident. Refit the spark plugs and the H.T. leads. (Each H.T. lead has a numbered plastic sleeve, No. 1 applying to the right side cylinder).

NOTE: The inspection covers are not interchangeable.

SECTION B6

REMOVING AND REPLACING THE AIR FILTER

The common air filter unit has rubber grommets which fit over plain sleeves on the carburetor intakes to provide airtight joints and these grommets must be in good condition for the filter to be effective. The whole assembly is secured to the carburetor adaptor by means of two bolts and locknuts, the main nuts being inside, and part of the filter box.

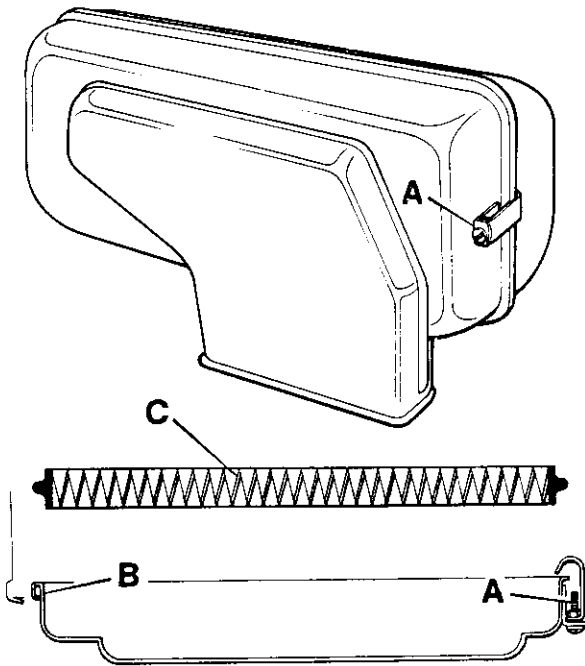


Fig. B8. The air filter, showing the lid and filter unit

To dismantle the unit, first unscrew the clip "A" Fig. B8, and disconnect the crankcase breather pipe; then extract the rubber buffer from beneath the main body of the filter.

The lid of the unit is "unhooked" from the left side of the body, following removal of the retaining screw on the right side. The filter itself can then be removed. Owing to the construction and nature of the filter material, it is not advisable to attempt to clean it and it should be replaced by a new one. Note especially, that the new filter is marked on one face with the words 'ENGINE SIDE' and must be fitted with this face towards the carburetors. To remove the main body, slacken the two locknuts on the bolts at the back of the body and then unscrew the bolts.

When re-assembling, tighten the bolts just sufficiently to ensure that the grommets are seated against the face of the collars on the carburetor intakes, and lock in position with the nuts. Do not tighten excessively, since the body may be distorted with consequent air leakage and hence reduced filtering efficiency.

SECTION B7

CARBURETTER DESCRIPTION

The 626 type carburetor Fig. B9 has the float concentric with the main jet. The float needle seating is integral with the float chamber which is secured to the main body by two cross-head screws. A captive tickler is used, the one on the centre carburetor being operated by a side lever. Rubber "O" rings provide the necessary friction on the pilot air screw. The carburetor top is secured by two crosshead screws. The throttle valve has a conventional return spring, and the air slides are controlled by a junction box from one lever. This primary air choke has a compensating action in conjunction with bleed holes in the needle jet, which serves the dual purpose of providing air to compensate the mixture from the needle jet, and also to provide a well, outside and around the needle jet, which is

available for snap acceleration. The idling mixture is controlled by the pilot air screw which governs the amount of air that is allowed to mix with the fuel at tick-over speeds.

Removal of the drain plugs Fig. B12 below the float chamber makes the main jet M accessible for unscrewing with a tubular wrench. Do not tighten the jet assembly excessively, since this may lead to the unscrewing of the jet holder at the next removal of the jet.

The main jet, throttle valve, needle and needle jet sizes have been selected by the factory to give the best results and should not be altered without expert advice.

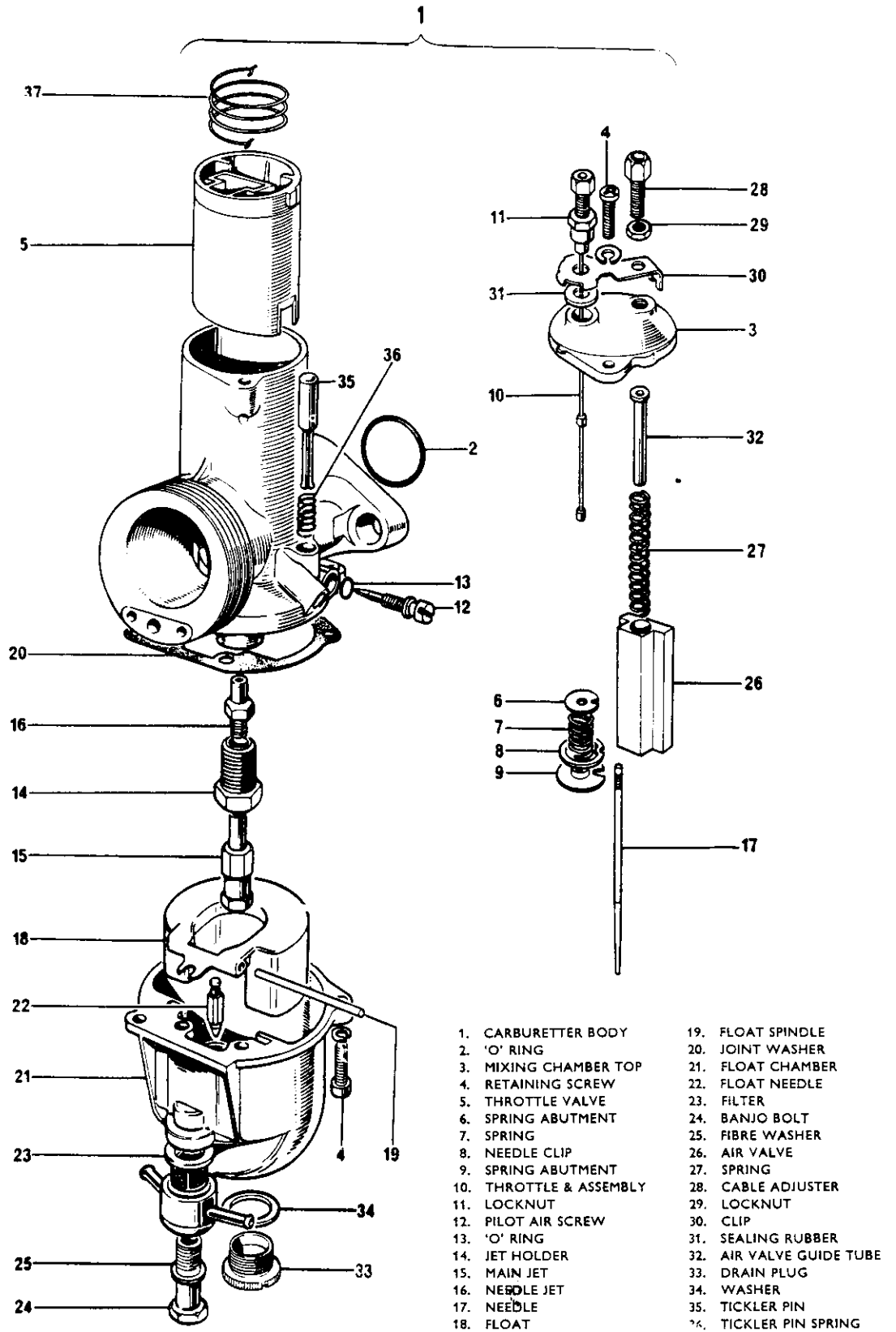


Fig. B9. Exploded view of carburettor

SECTION B8

REMOVING AND REPLACING THE CARBURETTORS

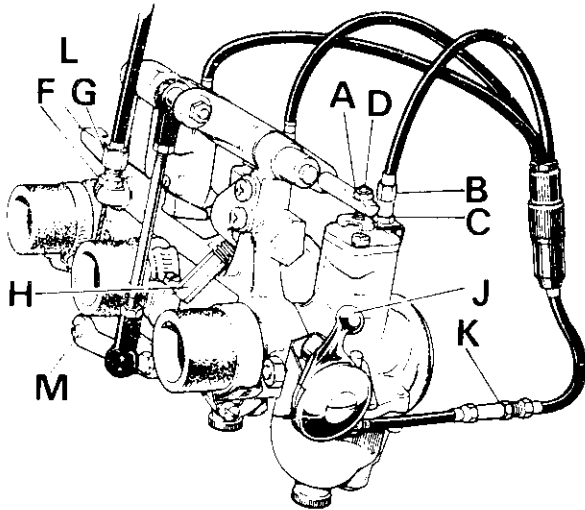


Fig. B10. Inlet manifold assembly

Remove the side panels (Section E2) and then the petrol tank (Section E1). Disconnect the throttle cable from the throttle linkage at F, G, and M, Fig. B10, and disconnect the air control cable from the lever J, Fig. B10. Slacken off the clips at the carburetor end of the rubber sleeves, and if the air filter assembly is still in position, remove the rubber buffer situated on the crankcase below the filter box, followed by the short breather hose from beneath the filter housing. Remove the lid and filter from the filler box (Section B6) when

following the slackening of the connecting pipe clips, the carburetors, manifold and filter can be withdrawn from the left side of the machine as a complete assembly.

To remove a carburetor first uncouple the fuel line at the banjo bolt below the carburetor. Then unscrew the two cross-head screws which retain the carburetor cap, and remove the two flange nuts. The carburetor can then be drawn off the studs and downwards, leaving the air and throttle slides in position on the operating arm.

To disconnect the carburetor cap from the arm, uncouple the throttle valve from its rod and the air valve from its cable. In the case of the throttle valve, remove the needle retaining spring clip and compress the throttle rod spring so that the top retaining plate can be extracted. Push the bottom nipple of the throttle rod downwards clear of the throttle valve. Removal of the air valve necessitates only compression of the spring whilst the cable nipple is pushed clear of the slide. Unscrew the air cable abutment to free the carburetor cap completely.

During re-assembly, care must be taken with the reconnection of the throttle valve and rod to ensure proper location and security. Similarly, replace the needle carefully into the needle jet, to avoid the risk of bending. Tighten all six connection clips securely, and make sure that the joints are airtight. Refer to Fig. B9 and B10 for guidance.

SECTION B9

STRIPPING AND REASSEMBLING THE CARBURETTORS

Each carburetor will already be less the cap, valves and needle with clip as removed from the machine.

Unscrew the two cross-head screws and remove the float chamber. Lift out the float, float spindle and float needle. Neither the pilot jet nor the tickler can be removed. Unscrew the air screw, hold the

main jet holder with one wrench whilst the main jet is unscrewed with another. Unscrew the main jet holder and remove the needle jet from this. Clean all parts thoroughly by washing in gasoline, (petrol). Deposits on the carburetor body are most successfully removed with the use of a light grade wire brush.

It is advisable to wash individual parts several times in a quantity of clean gasoline (petrol) to ensure absolute cleanliness. Allow the parts to dry but if possible use a jet of compressed air from such as a hand pump or air line to clear all holes and drillings. Inspect all parts for wear and check that the jets are in accordance with those recommended in GENERAL DATA, page GD4.

Reassembly is a reversal of the foregoing, referring to Fig. B9, for guidance.

During reassembly fit a new "O" ring at the pilot air screw, and new fibre washers in replacement of any which may have deteriorated. Be careful to locate both ends of the float spindle in the float chamber recesses provided and note that the float needle is assembled with its pointed end downwards. When the mixing chamber body is assembled to the carburetor valve, air valve and carburetor cap, take special care that the locating peg is lined up with the groove in the body.

SECTION B10

INSPECTING THE CARBURETTOR COMPONENTS

The only parts liable to show wear after considerable mileage are the throttle valve, mixing chamber and the air valve.

- (1) Inspect the throttle valve for excessive scoring to the front area and check the extent of wear on the rear face. If wear is apparent the valve should be renewed. In this case, be sure to replace the valve with the correct degree of cut-away (see "General Data").
- (2) Examine the air valve for excessive wear and check that it is not actually worn through at any part. Check the fit of the air valve in the throttle valve. Ensure that the air valve spring is serviceable by inspecting the coils for wear.
- (3) Inspect the throttle return spring for efficiency, signs of cracking, or breakage and loss of compressive strength.
- (4) Check the needle jet for wear or possible scoring and carefully examine the tapered end of the needle for similar signs.
- (5) Examine the float needle for wear by inserting it into the inverted float needle seating block pouring a small amount of gasoline (petrol) into the aperture surrounding the needle and checking it for leakage.
- (6) Ensure that the float does not leak by shaking it, to hear if it contains any fuel. Do not attempt to repair a damaged float. A new one can be purchased for a small cost.
- (7) Check the fuel petrol filter, which fits over the needle seating block, for any possible damage to the mesh. This would allow the gasoline (petrol) to by-pass it un-filtered.

SECTION B11

RESETTING THE CARBURETTORS

The carburetor assembly must be removed from the machine in order to synchronise the throttle slides. Refer to Section B8 for the removal procedure.

SYNCHRONISING THE THROTTLE VALVES

Remove the air filter and arrange the carburetor and inlet manifold assembly, on a work bench. Examine the throttle valves through the engine side of the carburetors, and re-set the adjuster screw (above each carburetor) until the valve on one

carburetor is open approximately 0.010 inches. Compare the other two valves, and adjust their heights by screwing the individual adjusters clockwise to lower the valves, and counter-clockwise to raise the valves. There is a locknut on each adjuster, and this should be tightened when the adjustment is completed.

The difference in valve heights is easily visible (see Fig. B11).

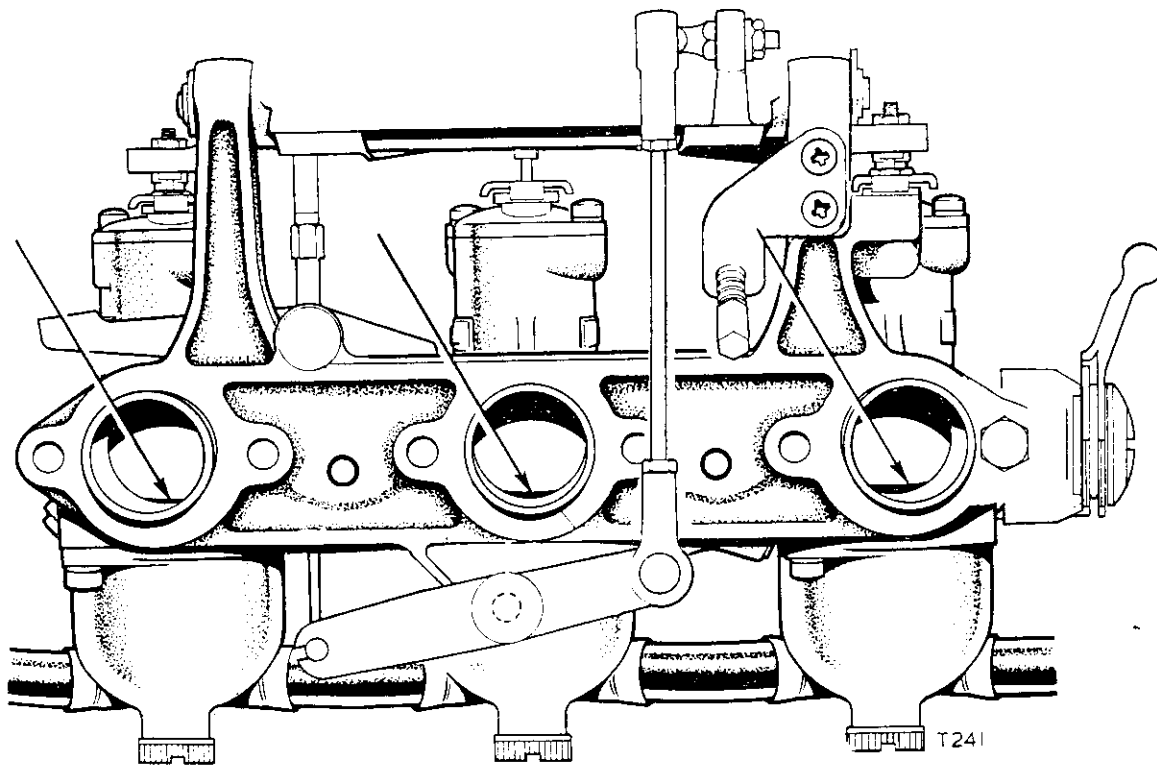


Fig. B11. Synchronising the throttle slides

PILOT MIXTURE

It may be necessary to make small adjustments to the pilot mixture to suit different climatic conditions and give good idling.

Screwing in the pilot air screw J, gives a richer mixture and vice-versa. Whenever adjustment is made to the pilot air screw on one carburetor, it must be accurately repeated on the others. Alternatively, the air screw should be gently screwed inwards as far as possible and then unscrewed by about 2 turns, the amount varying with requirements.

PRIMER (OR "TICKLER")

Depression of the plunger P Fig. B12 enriches the mixture for starting purposes by raising the fuel level in the float chamber and must be used only momentarily, since excessive "flooding" may cause difficult starting. In this event, switch off the ignition, open the throttle wide, and operate the starter pedal several times, to clear the fuel. Repeat the starting procedure without further priming.

NOTE: The primer on the center carburetor is operated by means of a rocking lever.

SLOW RUNNING

Following adjustments to the pilot mixture, the engine idling speed may require re-adjustment. It can be increased or decreased by movement of the master screw H Fig. B10 which controls all the carburetors simultaneously.

CHOKE CABLES

Cable abutment B Fig. B10 and locknut C allows individual cables to be adjusted for length to ensure equal opening of the air valves. The single cable between the control lever J and the triple cable junction box is fitted with a sleeve adjuster K which serves as a master adjustment for all the air valves.

THROTTLE CABLE

Excessive slackness in the cable can be taken up by adjustment of the sleeve screw G Fig. B10 and locknut F.

Individual setting of the throttle slides is by means of adjuster D Fig. B10 and locknut A. They are correctly set at the factory but, if any adjustment is made, it must be identical on each carburetor.

ALTITUDE

The settings given on page GD4 are those normally recommended and will be suitable for most atmospheric conditions. They are intended for altitudes up to 3,000ft. (1000m). Above this height some reduction in main jet size is necessary to provide a balanced mixture. For altitudes between 3,000 ft. and 6,000 ft. (2,000 m.) a reduction in main jet size by 5 per cent is usually necessary, and for every 3,000 ft. increase over 6,000 ft. a further 4 per cent is required.

If the float bowl is removed (screws N Fig. B12) take care not to damage the float and make sure the gasket R is in good condition before replacing.

Refit the carburetor assembly to the machine (Section B8) and adjust the throttle stop screw to give an idling speed of approximately 500 r.p.m.

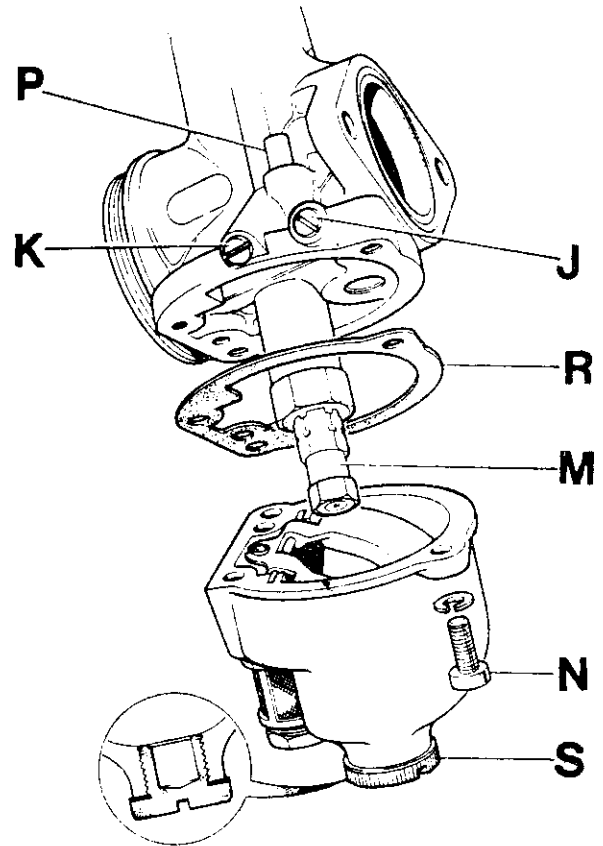


Fig. B. 12. The float chamber and jets

SECTION B12**REMOVING AND REFITTING THE CYLINDER HEAD ASSEMBLY**

Proceed as in Section B2, removing and replacing the rocker boxes.

Slacken the exhaust pipe clips at the collector box below the engine. Remove the bolt which couples the inner exhaust pipes (in front of the cylinder head), and slacken the finned clips on the outer exhaust pipes adjacent to the head. The pipes can now be drawn forwards off the exhaust stubs using, if necessary, a mallet for this purpose.

Remove the carburetor and air cleaner assembly (Section B8), and remove the four remaining cylinder head securing nuts and plain washers, one turn at a time, until the load has been released. Lift the cylinder head off the locating studs, and remove the gasket.

If the gasket is in good condition, it may be re-used, but it should first be annealed by heating to a dull red heat and plunging edgeways into cold water.

If in doubt about the efficiency of the gasket, it must be replaced by a new one.

REFITTING THE CYLINDER HEAD

Ensure that the junction surfaces of the cylinder block, and head are clean. Before assembling the gasket, a coating of Silastic sealant Q3-3305, or equivalent product, must be applied around the six dowel holes, on the top face only. Then place the gasket in position over the cylinder barrel studs and dowels.

Lower the cylinder head into position and fit the four outer cylinder head nuts and plain washers finger tight. Continue as described in Section B2, refitting the rocker boxes. (see Fig. B13)

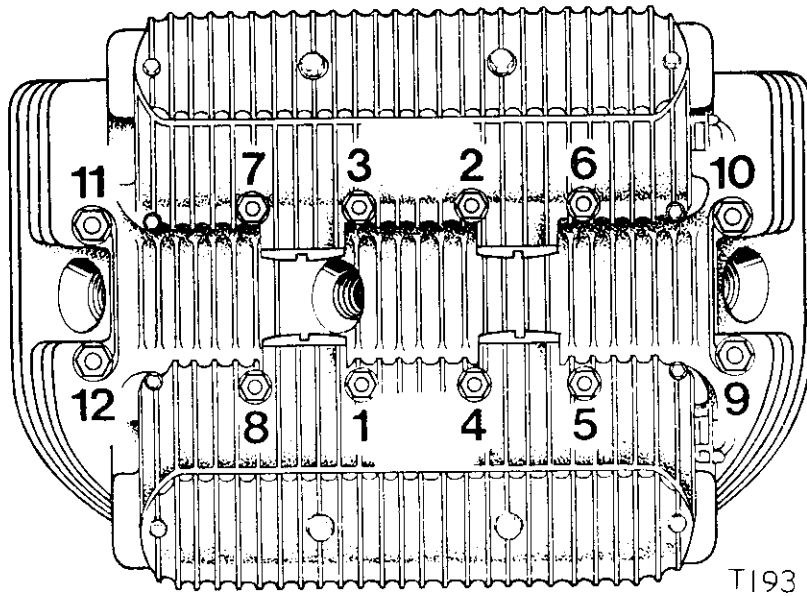


Fig. B13. Cylinder head bolt tightening sequence

When re-assembling the pipes make sure that the finned clips on the outer pipes and the tie-bolt for the inner pipes is securely tightened.

Similarly, make sure that the pipe clips at the collector box are tight. Refit the carburetor and air cleaner assembly (Section B6 and B8).

SECTION B13 REMOVING AND REFITTING THE VALVES

Removal of the valves is facilitated by means of a "G" clamp type valve spring compressor, see Fig. B14. When the spring is compressed sufficiently, the split cotters can be removed with a narrow screwdriver, and the valve spring withdrawn when the compressor is released. It may assist in releasing the cotters if the tool is given a sharp blow with a hammer, near to the end of the valve stem, after the spring has been compressed slightly.

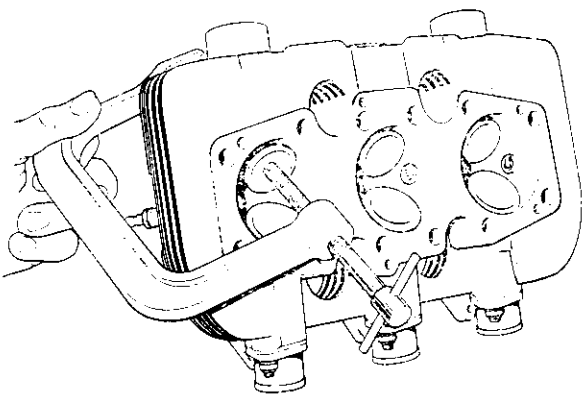


Fig. B14. Removing the valves

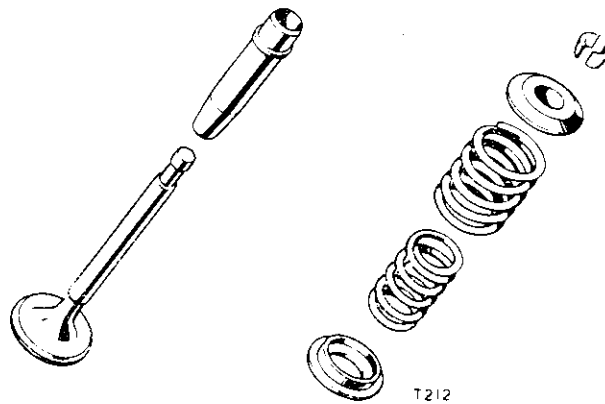


Fig. B15. Valve components

Fitting a new or reground valve necessitates seating by the grinding in process described in Section B16, but it does not necessitate recutting the cylinder head valve seat unless new valve guides have been fitted.

The valve springs should be inspected for cracks and fatigue, the latter being determined by the spring length, which should be checked against that given in the General Data, page GD3. If the spring has settled by more than $\frac{1}{16}$ in. it must be replaced.

All parts should be thoroughly cleaned in kerosene (paraffin) and allowed to drain before reassembling.

* Assemble the inner and outer springs and top and bottom cups over the valve guide, then slide the valve into position having first lubricated the stem with a small amount of graphited oil.

Compress the springs with the Service tool and slide the split cotters into the exposed groove in the valve stem.

When the assembly is completed it is advisable to tap the end of each valve stem with a hide faced mallet to ensure that the cotters are fitted securely.

* Each outer spring has a closed coil (i.e. reduced pitch) at one end. This end carries the colour code identification, and must be fitted towards the cylinder head.

SECTION B14 RENEWING THE VALVE GUIDES

The valve guides can be extracted using service tool 61-6063 as shown in the illustration B16.

The same method may be employed to fit the new guide, except that the replacement portion of the tool is used, to avoid causing damage to the knife edge of the guide.

When re-assembling, lightly grease the valve guide and ensure that the guide is pressed in until the shoulder is flush with the cylinder head.

When new guides have been fitted it is necessary to re-cut the valve seats in the cylinder head and grind in the valves (section B16).

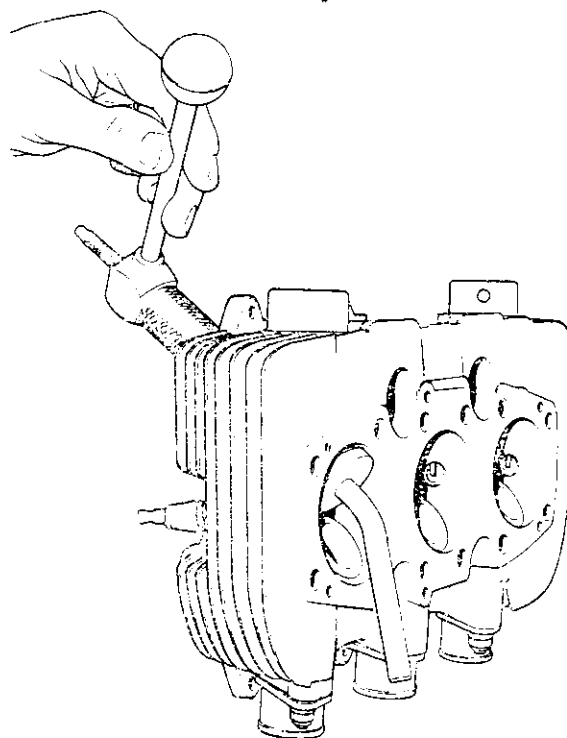


Fig. B16. Using assembly tool to replace valve guide

SECTION B15 DECARBONISING

Decarbonising involves the removal of carbon deposits from the piston crowns, combustion chambers, ports, valve heads, etc.

The presence of carbon, which is one of the products of combustion, is not harmful to the engine providing that it is removed before the deposits

become excessive and therefore likely to cause pre-ignition or other faults which may impair performance.

The usual symptoms, indicating the need for decarbonising are, a tendency to "pink" (metallic knocking sound when under load), a general falling

off of power noticeable mainly on hills, a tendency for the engine to run hotter than usual and an increase in petrol consumption.

When the cylinder head is removed, unscrew the sparking plugs and have them grit-blasted and checked. Before fitting the plugs, check that the gap setting is correct as listed in the owners handbook.

Rotate the engine to bring each piston in turn to the top of the bore, and remove the carbon from the crown, using a suitable scraper such as a stick of tinsmiths solder, flattened on the end to form a scraper.

Do not use a screwdriver or a steel implement of any kind on an aluminium surface.

Leave a narrow ring of carbon round the edge

of the piston crowns and do not remove the ring of carbon at the top of the cylinder bores. An old piston ring placed on top of the piston will assist in this operation.

After cleaning the pistons, again rotate the engine to lower the pistons to the bottom of their bores and wipe all loose carbon from the cylinder walls.

Remove the valves (Section B13) then remove the carbon deposits from the valve stems, combustion chamber and ports of the cylinder head. Remove all traces of carbon dust by means of a jet of compressed air or the vigorous use of a tyre pump, then thoroughly clean the cylinder head and valves in kerosene (paraffin). Finally, check the valves for pitting. If necessary, the valves can be ground-in as shown in Section B16.

SECTION B16

RE-SEATING THE VALVES

Examine the face of the valve to see if it is pitted, burnt or damaged. If necessary, the face can be reground, but excessive re-grinding is not advisable since this adversely affects vapour flow, and hence performance, and will ultimately result in critical pocketing. This, in turn, will require excessive use of the blending cutter.

Where the valve guides have been renewed or the condition of a valve seat is doubtful, it is advisable to re-cut the cylinder head valve seat then grind in the valve, using a fine grade of grinding-in paste.

It is important that the cylinder head valve seat and the valve guide bore should be concentric. For the purpose of re-cutting the valve seats the following service tools are available. (see tools section)

- 60-1833 Inlet seat cutter (45°)
- 60-1832 Exhaust seat cutter (45°)
- 60-1835 Exhaust seat blender
- 60-1863 { Holder—seat cutters
- { Pilot—seat cutters
- { Tommy bar
- { Tommy bar—cutter pilot

The valve seat cutting operation should be carried out with the greatest care, and only a minimum amount of metal should be removed (Fig. B17).

After the seats have been re-cut, use the blending cutter to the seat width to a constant $\frac{3}{32}$ in. (2.4 mm.).

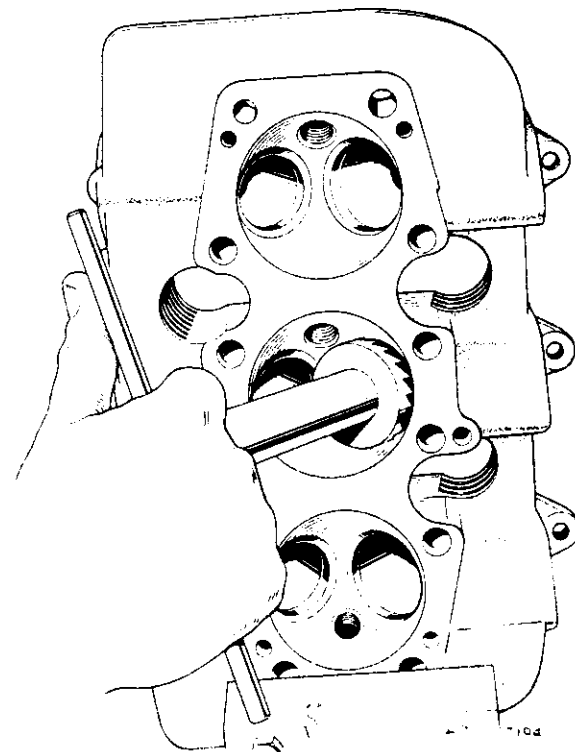


Fig. B17. Cutting a valve seat

To grind in the valve use a fine grade carborundum grinding paste but before returning the valve to its seat, insert a light spring under its head to assist in raising the valve when rotating to a new position see Fig. B18. Place a small amount of paste evenly on the valveseat and replace the valve in its guide with a holding tool attached.

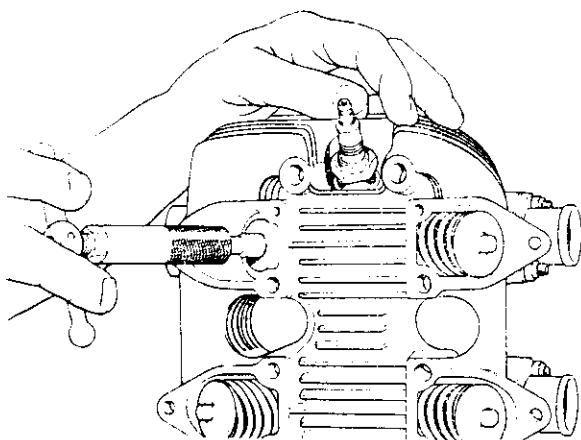


Fig. B18. Valve grinding

Use a semi-rotary motion, occasionally lifting the valve and turning it through 180°. Continue this process until the face and seat show a uniform matt finish all round. Wash the parts in kerosene (paraffin) to remove the grinding paste. Apply a smear of "Engineer's" marking blue to the seat of the valve. Rotate the valve through one revolution and inspect both seats. Successful valve grinding will give an unbroken ring of blue on the valve seat.

Alternatively, assemble the springs and split cotters and pour a small amount of kerosene (paraffin) into the port. It should not penetrate the seating for at least 10 seconds if a good seal has been achieved.

Prior to reassembling the cylinder head, ensure that all traces of "Blue" or grinding paste are removed by thoroughly washing in kerosene (paraffin).

SECTION B17

REMOVING AND REPLACING THE CYLINDER BLOCK AND TAPPETS

Proceed as in Sections B2 and B12, for removal and replacement of the cylinder head and rocker boxes.

Remove the cylinder base nuts, and plain washers. First, release the load on each nut in turn, starting from the outer nuts and working in a diagonal pattern and then remove. Secure the six cam followers using rubber bands or "O" rings so that they will not drop into the crankcase mouth as the block is lifted. The tappet guide blocks will remain in the cylinder block. Gently lift the cylinder block over the three pistons, ensuring that as each piston is released, its connecting rod is protected from being scratched or suffering other possible damage. A scratch could initiate a fatigue failure. Sleeves made of sponge rubber taped together and fitted over the connecting rods will make ideal protectors. (See Fig. B19).

When the cam followers are removed from the tappet guide blocks, ensure that they are stored in their correct order of removal, because they must be replaced in the same order to avoid excessive cam and tappet wear. Wash all parts thoroughly in clean gasolene (petrol).

If it has been decided to fit new piston rings, then the cylinder bores must be lightly honed as described in Section B21.

The joint surfaces of both the cylinder block and crankcase, must be clean. Before replacing the cylinder block, assemble the cam followers into the tappet guides. Make sure that they are fitted in the correct position. It is advisable to use a new gasket.

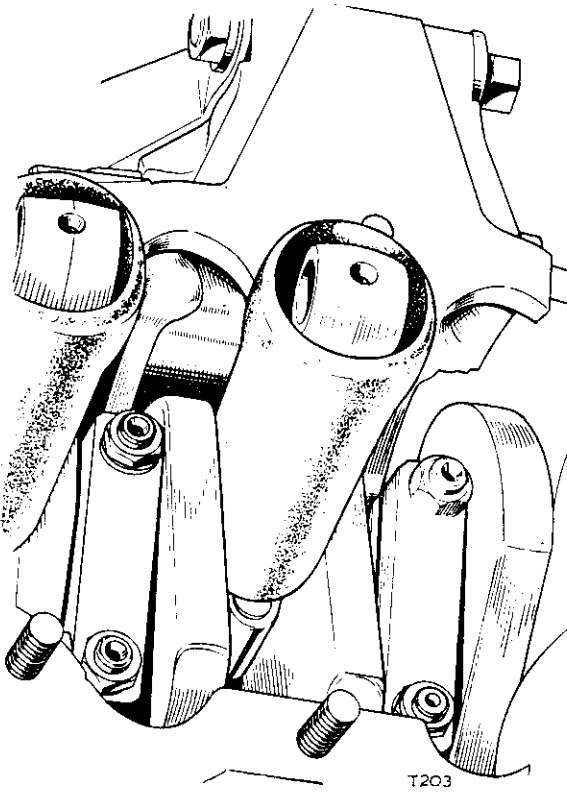


Fig. B19. Protecting the con. rods

RE-ASSEMBLY

Position the crankshaft with the centre piston at bottom dead centre. Support outer pistons at blocks of wood placed across the crankcase mouth to keep them vertical and prevent them from being damaged on the cylinder base studs. Smear the bores and pistons lightly with engine oil. Compress the rings on the outer pistons with the use of toggle

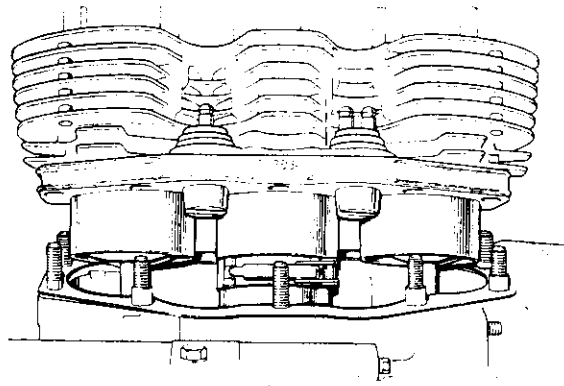


Fig. B20. Refitting cylinder block

type clamps, part No. 61-6052. Retain the rubber rings on the cam followers to avoid the possibility of these falling into the crankcase, and mount the cylinder block on the two outer pistons, ensuring that the square fins of the block are at the front of the engine. Lower the cylinder block over the pistons, and when all six rings have entered the bores, remove both toggle clamps and the wood blocks. While an assistant holds the cylinder block in this position, fit a toggle clamp over the centre piston rings, (see Fig. B20), and lower the cylinder block still further, until these rings also are in the block, and remove the clamp. Slide the cylinder block fully home onto the crankcase studs, and fit the plain washers and special nuts. Tighten down evenly, working from the centre nuts outwards.

SECTION B18

INSPECTING THE CAM FOLLOWERS

The bases of the cam followers are fitted with a "stellite" tip. This material has good wear resisting qualities but the centre of the tips may show signs of

slight indentation. If the width of the indentations exceed $\frac{3}{32}$ in. then the cam follower should be renewed.

SECTION B19

INSPECTING THE TAPPET GUIDE BLOCKS

The guide blocks are pressed into the cylinder block, and are retained by pressed in aluminium alloy pegs.

No attempt should be made by the private owner to remove the guide blocks.

Wear in the guide block can be estimated by rocking

a tappet whilst it is in position. It should be a sliding fit with little sideways movement (see GENERAL DATA for correct clearance).

If the guide blocks are in need of renewal, the cylinder block must be returned to a Triumph dealer.

SECTION B20

REMOVING AND REFITTING THE PISTONS

It is most important that the connecting rod protective rubbers are securely fitted at this stage.

First, thoroughly warm the piston to avoid the risk of damaging the wrist pin hole during extraction of the pin. This is simply accomplished by applying

a heated electric iron for a few moments to the piston crown.

Remove the circlips from the pistons with the aid of a pair of circlip pliers. Withdraw the wrist pins using a proprietary tool (Fig. B21).

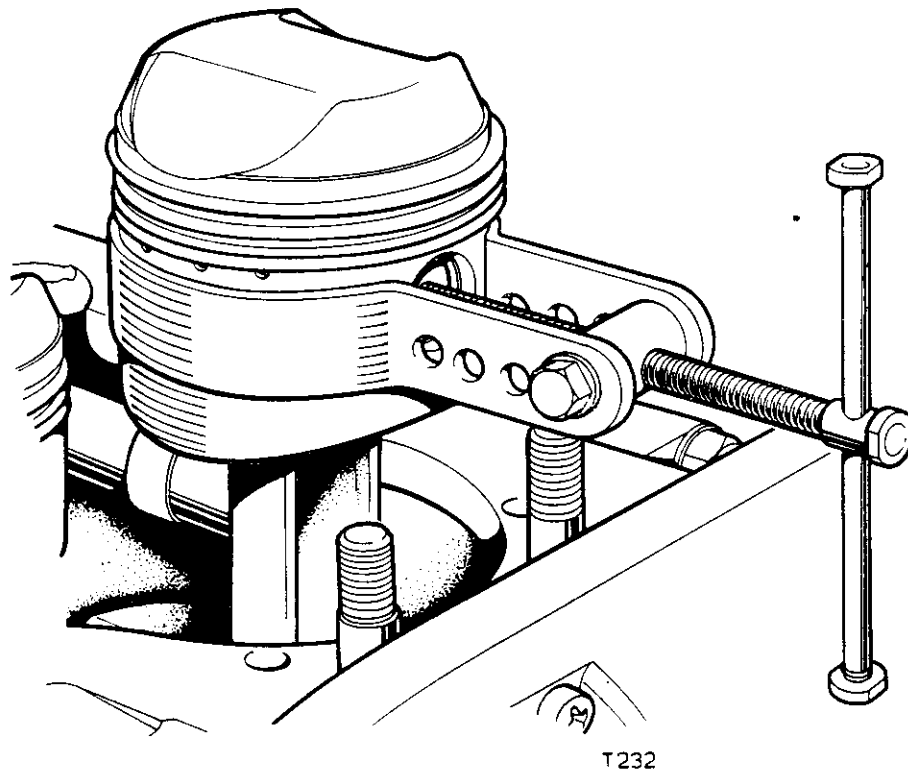


Fig. B21. Removing a piston

Alternatively in the absence of such a tool the pistons may be removed by driving out the wrist pin with a suitable drift after warming the pistons as already described. However, this is not a recommended practice, and may result in a damaged piston or distorted connecting rod. **The need for care cannot be over-stressed when using this method to remove the wrist pin.** When the pistons are removed they should be suitably scribed inside so that they can be refitted in their original positions. Each piston has "FRONT" stamped on the crown.

When refitting the pistons first place the inner circlip in position to act as a stop, then press the wrist pin into position using the proprietary tool.

It is advisable to renew the six circlips; this can be done for negligible cost.

If there is no alternative but to drive the wrist pin into position with a drift, the piston should first be heated to 100 degrees centigrade (boiling water temperature) to assist assembly. Dry thoroughly before use.

Finally, check that all the wrist pin retainer circlips are in position, and are correctly fitted. **This is extremely important.**

SECTION B2I

REMOVING AND REPLACING THE PISTON RINGS

There should be little difficulty in removing piston rings, if the following procedure is adopted. Lift one end of the top piston ring out of the groove and insert a thin steel strip between the ring and piston. Move the strip round the piston, insert a second and then a third strip, as shown in Fig. B22. The rings should always be lifted off and replaced over the top of the piston.

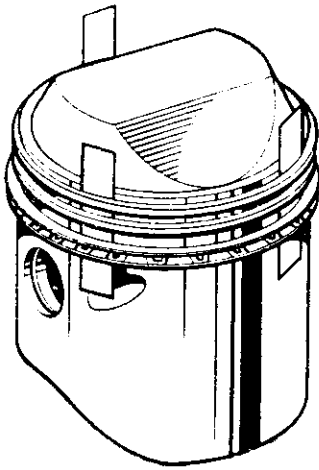


Fig. B22. Piston ring removal

If the piston rings are to be refitted, the carbon deposits on the inside of the rings, and the deposits in the ring grooves, must be removed.

When fitting new piston rings, the bores must be lightly honed with a fine-grade emery cloth so that the new rings can become bedded down properly. The honing should be carried out with a combined oscillatory and reciprocating motion until an even "criss-cross" pattern is achieved. The recommended grade of emery cloth for this purpose is No. 300. Thoroughly wash the bores in kerosene (paraffin) and check that all traces of abrasives are removed.

Pistons and rings are available in .010, .020, and .040 inches (.254, .508 and 1.016 mm) oversizes. When fitting new rings, the gap must be checked in

the lowest part of the cylinder bore. The ring must lie square to the bore for checking purposes, and to ensure this, place the piston crown onto the ring and ease it down the bore. Check the gap with feeler gauges.

Piston rings, when new, should have the following gap clearances:

Compression ring gap: .009-.013 in. (.2286-.3302 mm.)

The gap for the 'APEX' type scraper ring may be quite large without harmful effect (up to approx. .040 in.)

Refitting the piston rings is straight forward, but check that the two compression rings are fitted the right way up.

These two rings are marked "TOP" to ensure correct assembly, and should be fitted with the "TOP" marking towards the cylinder head (see Fig. B23).

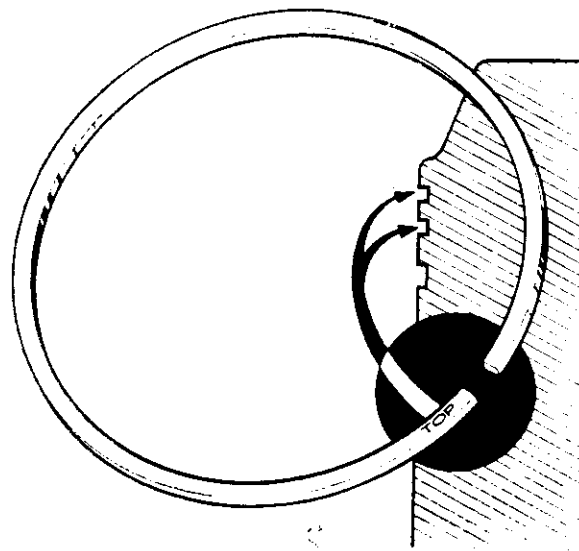


Fig. B23. Refitting a tapered piston ring

SECTION B22

INSPECTING THE PISTONS AND CYLINDER BORES

PISTONS

Check the thrust areas of the piston for signs of seizure or scoring.

High spots, leading seizures, are indicated by bright patches and scoring, following a seizure, is shown by deep scratches and injury to the surface of the piston. High spots may be removed with a few strokes of a fine file. Sometimes, following a seizure, the rings become trapped and again careful action with a file or scraper is required to release them.

The piston skirt is of a special oval form and is designed to have limited working clearance within the bores. The clearances are given in GENERAL DATA, page GD4.

Prior to inspection, ensure that both the cylinder bores and pistons are clean and free from dirt, etc. Any deposits of burnt oil round the piston skirt can be removed by using a gasoline (petrol) soaked cloth.

NOTE: The top lands on pistons have a greater working clearance than that at the

skirt and thus allow the top piston ring to be viewed from above, and the piston to be rocked slightly. However, this is not critical; it is the skirt clearances that are all important.

CYLINDER BORES

The maximum wear usually occurs within the top half inch of the bore, whilst the portion below the piston ring working area remains relatively unworn. Compare the diameters, measured at right angles to the wrist (gudgeon) pin, to obtain an across the thrust faces, i.e. estimate of the wear. A difference between these figures in excess of .005 in. (.13 mm.) indicates that a rebore is necessary. Compare the figures obtained with those given below so that accurate information for the actual wear can be obtained.

An approximate method for determining the wear in a cylinder bore is that of measuring the piston ring gap at various depths in the bore and comparing with the gap when the ring is at the bottom of the cylinders. The difference between the figures obtained, when divided by three (an approximation of π) equals the wear on the diameters. As above, if the difference exceeds .005 in. (.13 mm.), this indicates that a rebore is necessary.

SECTION B23

TABLE OF SUITABLE REBORE SIZES

Piston size ins. (mms.)		Bore ins.	Size mms.
Standard	Max.	2.6366	66.970
	Min.	2.6355	66.942
0.010 (0.254 mm.)		2.6466	67.224
		2.6455	67.196
0.020 (0.508 mm.)		2.6566	67.478
		2.6555	67.450
0.040 (1.016 mm.)		2.6766	69.986
		2.6755	67.958

NOTE: Standard cylinder blocks are marked on the upper fin with the letters H, M or L as a production facility. These symbols should be removed by filing when a block has been re-bored. The recommended piston clearance is given in General Data, page GD4.

SECTION B24

REMOVING AND REPLACING THE CONTACT BREAKER

The contact breaker is housed in the timing cover on the right side of the engine, and is driven by the exhaust camshaft. It consists of three sets of points (one for each cylinder) and a fully automatic centrifugal type spark advance and retard mechanism. The working parts are protected by a circular cover and gasket. A seal is provided in the back of the housing to prevent the ingress of oil from the timing chest. The contact breaker plate is secured by three pillar bolts to the housing and the auto advance mechanism fits into the tapered hole in the end of the exhaust camshaft.

To remove the contact breaker assembly, first disconnect the battery feed terminal at the fuse holder. Remove the three screws and withdraw the chromium plated cover and gasket. Remove the centre bolt and screw in service tool 61-0782 until the auto advance cam is released from its locking taper in the camshaft. A sharp tap on the free end of the wrench will assist in disconnecting the taper joint. Unscrew the tool and remove three pillar bolts and plain washers from the contact breaker plate. Both the plate and auto advance can then be removed.

To detach the contact breaker completely, it will be necessary to disconnect the three leads at the snap connectors terminals behind the styling cover so that the leads can be withdrawn through the grommet in the timing case.

Prior to refitting the spark advance and retard unit it is advisable to add a small amount of oil to the pivot pins. (Refer to Section A11). The unit should be refitted into the camshaft taper, and the bolt refitted without tightening. The base plate should be repositioned so that the set of points with the Red/Black lead is to the rear of the engine. Replace the pillar bolts and plain washers.

Adjust the C.B. points (Section B25).

Reset the spark timing (Section B26).

When the correct setting is achieved for all cylinders ensure that the contact breaker screws are tight, then refit the cover and gasket.

IMPORTANT NOTE: "Run-out" on the contact breaker cam, or misalignment of the secondary backplate centre hole, can result in contact between the cam and backplate. This can result in the auto advance remaining in the retarded position. To check for "run-out", measure the points gap with the contact nylon heel aligned with the cam scribe mark for each set of joints. Should there be a discrepancy greater than 0.003 in., tap the outer edge of the cam with a brass drift (with the cam securing bolt remaining tight). In cases of misalignment of the secondary backplate hole, check the cam clearance in different positions, and elongate the hole only where the backplate rubs the cam.

SECTION B25

ADJUSTING THE CONTACT BREAKER POINTS

The base plate should be assembled with the Red and Black lead (2) to the rear of the engine.

To adjust the contact breaker gaps, turn the engine by means of the starter pedal until the scribe mark on the contact breaker cam aligns with the nylon heel of one set of points. Measure the gap using a 0.015 in. feeler gauge. The gauge should fit well with no apparent clearance, and without forcing the points apart. If the gap requires adjustment, slacken the contact securing screw A and rotate the eccentric screw B (see Fig. B24), as shown for the Red/Black lead

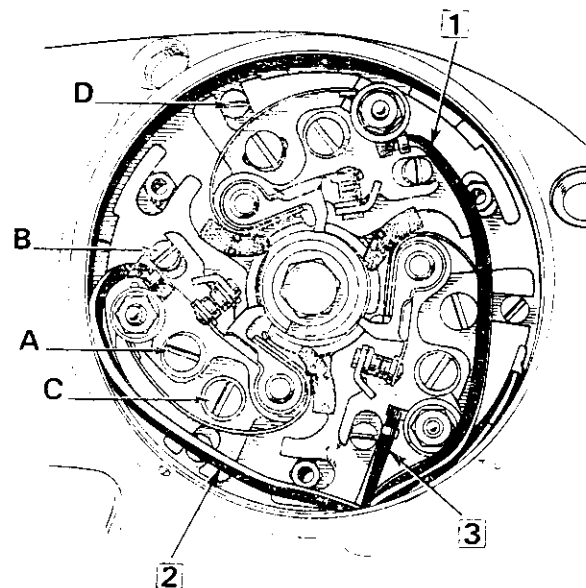


Fig. B24. Contact breaker, 7CA

Retighten the securing screw, and recheck the gap.

Repeat this procedure for the third contact set.

Revolve the motor until the second nylon heel is in line with the scribed mark and proceed as before.

NOTE: Setting the spark timing is fully described in Sections B26 and B27.

SECTION B26

RE-SETTING THE SPARK TIMING

STATIC TIMING

It should be noted that the firing order is cylinder numbers one, three, two. The three leads as shown in Fig. B24 are coloured White and Black for number one cylinder (right side), Yellow and Black for number three cylinder (left side) and red and black for number two cylinder (centre).

Before the spark timing is adjusted, the contact breaker points gap must be checked, and if not within the specified 0.014 in. to 0.016 in., they must be adjusted as described in Section B25.

The blanking plug for the spark timing hole is located at the front of the timing side of the crankcase, at the position shown in Fig. B25. This plug should be removed

(i.e. clearance on both tappets). Screw the service tool into the crankcase, and apply light finger pressure to the plunger. Turn the rear wheel slowly backwards, whereupon the plunger will locate in the hole drilled in the crankshaft web. The piston is now locked at 38° before TDC which is the correct spark timing position. If the auto advance unit has been removed, it should only be assembled loosely. Slacken and remove the auto advance central bolt, and fit an oversized washer A under the bolt (Fig. B26). When the bolt is tightened, the new washer will lock the cam in position. The auto advance unit should be replaced in such a position that number one points (Black and White lead) are just opened (0.0015 ins.) when the auto advance is locked in the full advance, (i.e. full clockwise) position.

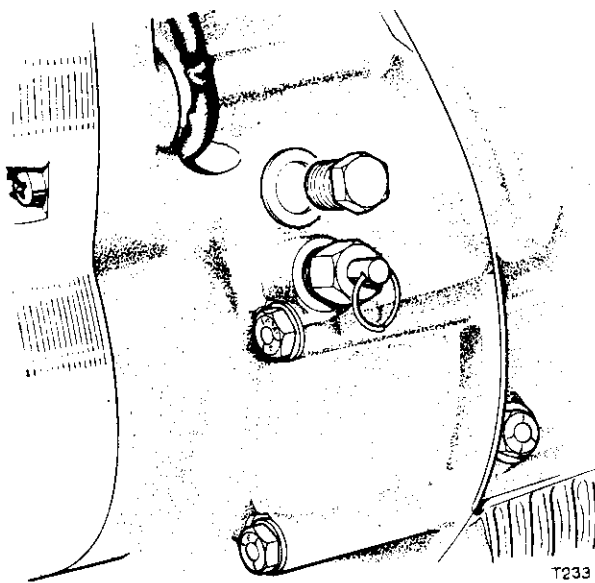


Fig. B25. Showing location tool in use

Remove both rocker covers, three sparking plugs and engage high gear to allow the engine to be rotated with the rear wheel. Rotate the engine forwards until top dead centre (TDC) is located on number one cylinder, with both valves closed

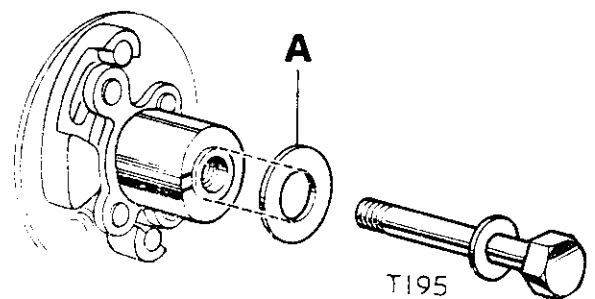


Fig. B26. Locking the auto advance mechanism

Recheck this setting and if found incorrect, the secondary back plate securing screw should be slackened, and the eccentric screw D (Fig. B24) turned to achieve the desired position. Retighten the securing screw, and recheck the point gap. If this is found to be satisfactory, withdraw the timing locating plunger. Establish the TDC position on the compression stroke on number three cylinder (Yellow/Black lead). Rotate the engine backwards until the timing plunger is felt to locate. If the contact points do not commence to open with the auto advance unit still locked in the full advance position slacken the secondary back plate securing screw C, and adjust the points on the eccentric screw D.

Retighten the securing screws, and withdraw the timing plunger. This procedure should be repeated for the centre cylinder (Red and Black lead).

Remove the auto advance unit centre bolt, and remove the oversize washer. Care should be taken to ensure that the auto advance unit is not released. Retighten the bolt.

The spark timing will now be correct on all cylinders. Remove the timing plunger and body, and replace the blanking plug and fibre washer. Refit the sparking plugs and rocker covers, and engage neutral position on the gear lever.

SECTION B27

IGNITION TIMING USING A STROBOSCOPE

Remove two upper screws and slacken the lower screw that secures the patent plate to the timing cover. There are three scribed lines on the rotor at 120° intervals, and the lower patent plate screw also serves as a pointer (Fig. B27).

use the machine's own battery. (A.C. pulses in the low tension wiring can trigger the stroboscope, and give false readings).

Remove the contact breaker cover plate and gasket, and ensure that the contact point gaps are correct (refer to Section B25 if necessary).

Start the motor and direct the stroboscope beam at the pointer and rotor mark. The engine should be run at a speed of not less than 3,500 r.p.m. when the pointer and line marked B should coincide. If these do not coincide, adjustment should be carried out on the Black/White contact point, by slackening the secondary bracket screws and adjusting the eccentric screw (Fig. B24). When an accurate setting has been obtained, retighten the secondary bracket screw.

Reconnect the stroboscope to the central spark plug, restart the motor and again direct the beam at the rotor mark. If adjustment is necessary, the Red/Black secondary bracket screw should be adjusted. Repeat this procedure for the left hand cylinder, and carry out any necessary adjustment on the Yellow/Black secondary bracket screw.

Ensure that all contact breaker screws are tight, replace the gasket and cover, and disconnect the stroboscope.

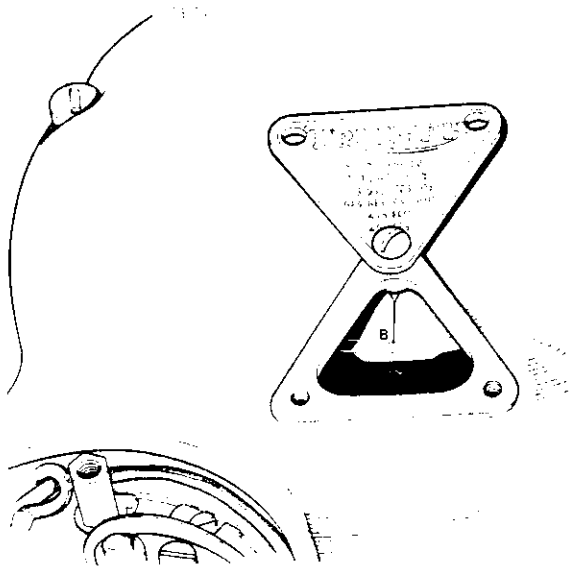


Fig. B27. Timing mark on the rotor

A stroboscope should be connected to the right side sparking plug and a power source.

NOTE: When using a stroboscope powered by a 12 volt battery as an external power source, do not

SECTION B28

REMOVING AND REFITTING THE TIMING COVER

Remove three contact breaker cover screws and the cover. Check that the gasket is in good condition, in which case it can be reused. Remove the contact breaker assembly and auto advance unit as described in Section B24.

Remove nine cross-head screws from the timing cover, and note that three long screws are fitted to the lower holes marked X, Fig. B28. A sharp tap at the edge of the cover will break the joint and the cover can be lifted clear.

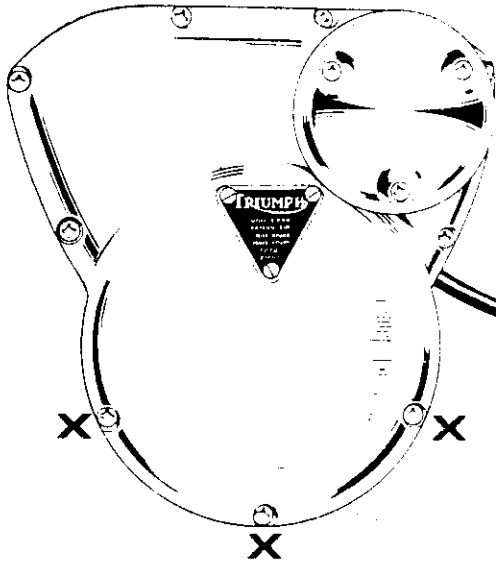


Fig. B28. Position of screws

Before refitting the cover, clean off all traces of old jointing compound from both the timing cover and crankcase faces. Examine the contact breaker housing oil seal for signs of cracks or other damage. If necessary, renew the seal by prising the old one out with a screwdriver, and fitting a new seal with spring side towards the engine. The seal must be tapped home level with the inner surface of the cover.

To refit the timing cover insert the oil seal protector tool 60-7013 into the end of the camshaft. Apply jointing compound to the joint surface of the timing cover, and refit the cover over the protector tool. The long screws are situated at the lower half of the cover. Securely tighten all screws. (See page GD8).

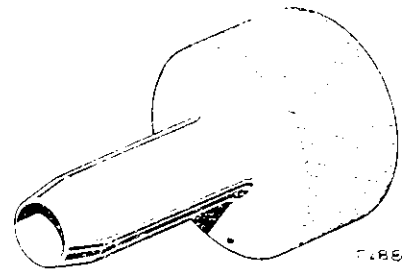


Fig. B29. Oil seal protector 60-1810

Withdraw the tool through the contact breaker housing. Replace the spark advance and retard mechanism, contact breaker, etc. as detailed in Section B24.

Adjust the C.B. points (section B25).

Finally reset the spark timing (Section B26.).

SECTION B29

EXTRACTING AND REFITTING THE VALVE TIMING PINIONS

Before attempting to remove any of the valve timing pinions, it is necessary to release the load on the camshafts, caused by valve spring compression. This can be achieved by prising the old one out with a screwdriver, and fitting a new seal with spring side towards the engine. The seal must be tapped home level with the inner surface of the cover.

Remove the contact breaker (Section B24), the timing cover (Section B28), and the alternator rotor and stator which are retained by three locking nuts and washers and a large nut and tab washer on the crankshaft.

Select low gear and if possible obtain the services of an assistant to apply the rear brake.

Remove the camwheel retaining nuts, bearing in mind that they have LEFT HAND threads, and hence must be turned clockwise to release.

Remove the circlip which retains the intermediate pinion, and withdraw the thrust washer. (Fig. B30).

CAMSHAFT PINIONS

To facilitate extraction of both the inlet and exhaust camshaft pinions tapped holes ($\frac{1}{4}$ in. U.N.F.) are provided for extractor screws. (A protection washer or cap must be placed over the end of the camshaft to prevent damage by the center bolt of the extractor tool). These must be tightened alternately,

by a very small amount at a time, in order to draw the pinions off their shafts as squarely as possible. (See Fig. B30).

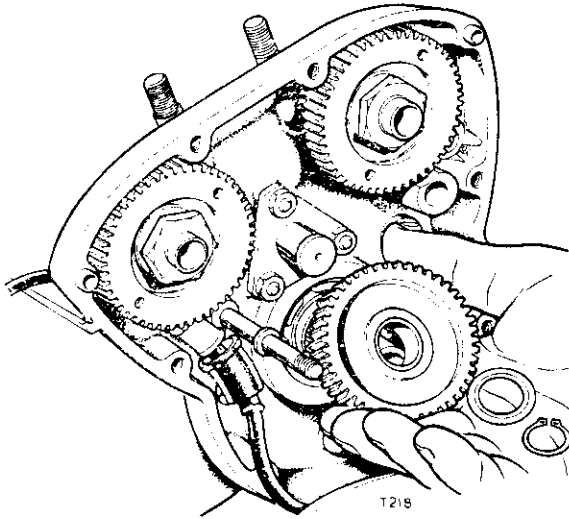


Fig. B30. Showing order of assembly of the intermediate pinion

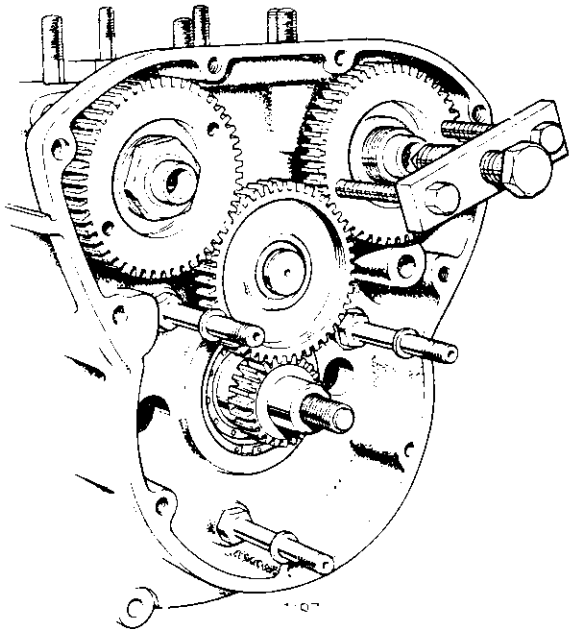


Fig. B31. Extracting camshaft pinion using tool 61-3808

The location keys in each camshaft are a tight fit, and may be left in position if it is not intended to remove the camshafts. The intermediate pinion can now be withdrawn.

When replacing the camshaft pinion, ensure that the keys are correctly located in the shafts. The pinion bore should be lubricated to assist assembly. Align the key to the keyway opposite the appropriate timing mark on the pinion, and gently tap the pinion home with a piece of tubing of suitable dimensions.

Tightening of the securing nuts (counter-clockwise rotation) will be simplified if carried out after the intermediate timing wheel and the crankshaft pinion are in position (i.e. under the same conditions as when dismantling).

CRANKSHAFT PINION

It is not necessary to extract the crankshaft pinion in order to dismantle the engine. Removal of the pinion is facilitated by service tool 61-6019 (see Fig. B32).

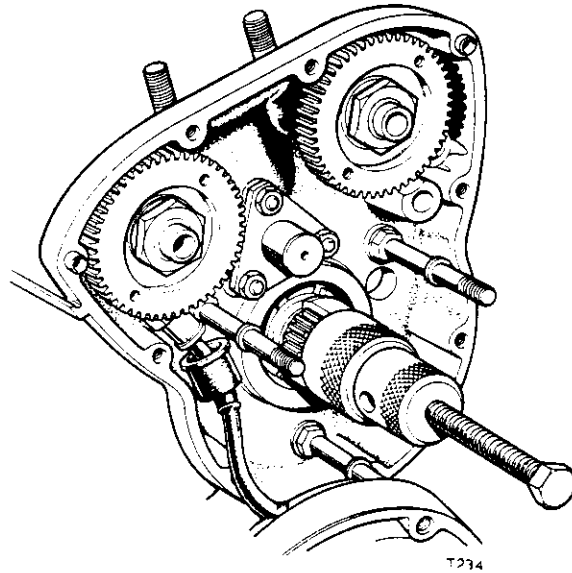


Fig. B32. Extracting the crankshaft pinion

To extract the pinion, unscrew the knurled collar on the extractor, at which point the claws will spread.

Position the extractor, ensuring that the claws are located in the recess behind the pinion, and tighten the collar. Screw in the bolt until the pinion is free.

A spacing washer is fitted behind the pinion, and if removed should be placed in safe-keeping.

RE-ASSEMBLY

Replace the spacing washer and re-fit the key to the shaft.

Fit the pinion with the chamfer and timing dot outwards.

Assembly of the pinion is aided by service tool 61-6024, which consists of a tubular drift and guide, and ensures correct alignment.

Screw the guide onto the crankshaft, and slide the pinion over it, after having greased the pinion bore. Align the key and key way, and drive the pinion onto the crankshaft.

SECTION B30

VALVE TIMING

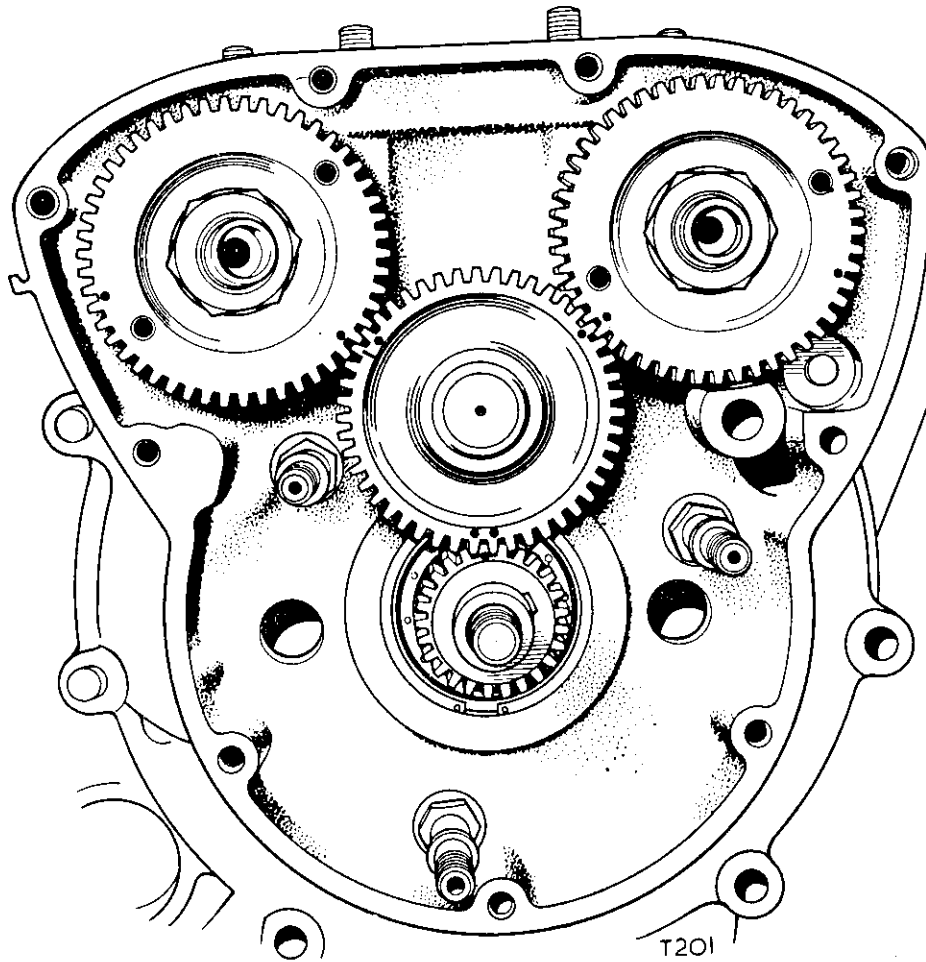


Fig. B33. Valve timing marks

Position the crankshaft and camshaft pinions so that the relevant timing marks are towards the intermediate pinion spindle. Assemble the intermediate wheel so that the timing marks coincide (see Fig. B33).

When checking the valve timing against the figures given in GENERAL DATA, it should be noted that these are relative to a valve rocker clearance of .020 in. for checking only.

Either camshaft can be advanced or retarded in steps of 15 degrees, which is equal to one tooth on the camshaft pinion, or 5 degrees by assembling the pinion on a different keyway.

Re-assembly notes are given in Section B29.

The ignition timing procedure is fully described in Section B26.

NOTE When checking the valve timing after assembly, due to the intermediate wheel having a prime number of teeth, the timing marks will only coincide every 94th revolution, thus there is no cause for alarm if the marks will not readily re-align.

SECTION B31

TO DISMANTLE AND REASSEMBLE THE CRANKCASE

- (1) Remove the engine unit (Section B1).
- (2) Remove the rocker boxes (Section B2).
- (3) Remove the carburetors (Section B8).
- (4) Remove the cylinder head (Section B12).
- (5) Remove the cylinder block (Section B17).

DO NOT FORGET TO PROTECT THE CONNECTING RODS FROM DAMAGE.

- (6) Remove the pistons (Section B20).
- (7) Remove the primary chain, engine sprocket, shock absorber, and gearshift cross-shaft. (Section C5-C7).
- (8) Remove the clutch and housing (Section C7).
- (9) Remove the oil pump (Section A7).
- (10) Remove the transmission (gearbox) outer cover (Section D2).
- (11) Remove the transmission (gearbox) inner cover and gear cluster (Section D7).
- (12) Remove the timing cover (Section B28).
- (13) Remove the rotor and stator.

To remove the right side crankcase section it is not necessary to remove the timing pinion and distance piece. If for any reason the pinion is removed, note that this is keyed to the crankshaft and will need the use of an extractor. The intermediate timing gear with its retaining circlip and thrustwasher must be removed next. For valve timing purposes on re-assembly, refer to Section B30. The right side case is located by dowels to the centre crankcase section, and after removal of two stud nuts and plain washers, five bolts with plain washers, and two socket head screws, one inside, and the other outside the timing case (See Fig. B34). The crankcase section can be with drawn with the aid of a light tap to break the sealed joint. To avoid any fouling caused by the cam lobes, the camshafts should be positioned so that the single lobes (i.e. those at the left end of the camshaft) point inwards.

Remove eight bolts and plain washers securing the left side crankcase section, and lightly tap the section to break the sealed joint (see Fig. B35).

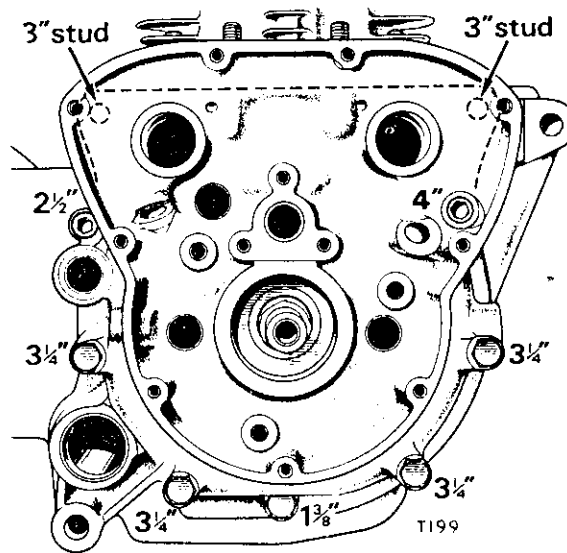


Fig. B34. Location of right side crankcase section

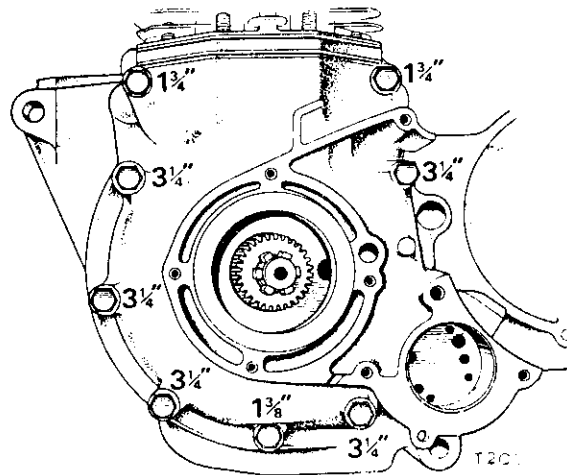


Fig. B35. Location of left side crankcase section

Separation of the left and right crankcase sections will expose the two housings carrying the cross-shaft oil seals, both of which should be removed for examination.

It is advisable at this stage to remove the oil pressure release valve (Section A6). The tachometer drive can now be removed from the crankcase (Section B36).

Remove four self locking nuts and washers from the main bearing caps, and as the caps are located on waisted studs, the crank should be lifted to free them. **Under no circumstances should the caps be prised off.** After removing the crankshaft the connecting rods and big end shells can be removed. The caps are retained by self locking nuts, and after removal of the connecting rods the caps should be refitted to them to ensure that they are reassembled to the corresponding connecting rods.

The gearbox sprocket and high gear should be removed (Sections D7, D11) in order to check the condition of the high gear bearing and oil seal. If these parts are worn they should be replaced. Do not attempt to use a seal which has shown signs of leakage. Remove six nuts and plain washers securing the sump plate to the centre crankcase section, and then the plate, two gaskets and the metal gauze filter. This filter should be cleaned thoroughly in gasolene (petrol). It is advisable, at this stage, to remove the anti-drain valve (Section A10), and also the two main bearing oil way plugs, which are situated at the front of the centre crankcase, above the finned base. These oil ways should be cleared with compressed air line (See Fig. B36).

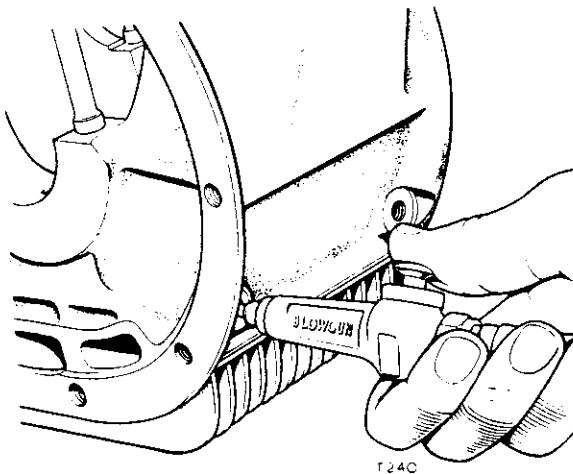


Fig. B36. Cleaning the crankcase oilways

CRANKCASE RE-ASSEMBLY

Prior to reassembly, all parts should be thoroughly washed in kerosene (paraffin) and should be scrupulously clean. All traces of old jointing

compound should be removed from the crankcase joint faces.

Replace the gearbox high gear and gearbox sprocket (Sections D7, D11), and the assembled tachometer drive unit (Section B36).

Assemble the lower main bearing shells into the crankcase, ensuring that the locking tab is to the rear on both shells. The top shell should be fitted into the main bearing caps, again ensuring that the locking tabs are to the rear of each shell.

When fitting the crankshaft to the centre crankcase, the connecting rods must be assembled to the crankshaft, and suitably protected from damage. See Fig. B19. The crankshaft should be fitted with the large diameter threaded end to the left hand side. Refit the main bearing caps complete with shells, and ensure that they are fitted in the same order as they were removed. Replace two plain washers and two self locking nuts on each cap, and tighten down to the torque figure given in GENERAL DATA page GD8. Check that the crankshaft rotates freely.

Replace the oil pressure release valve (Section A6), the anti-drain valve (Section A10), and two oil way blanking plugs and fibre washers. Any suspect fibre washers should be renewed.

Assemble the sump plate, ensuring that two new gaskets are fitted, one above the gauze filter, and one below. The sump plate is fitted with the pocketed end towards the rear of the engine.

During the remainder of the assembly, observe the following procedures.

Ring seals are fitted in the recesses at either side of the oil filter housing on the centre crankcase section. If the seals appear damaged in any way they should be renewed.

The housings for the cross shaft seals were themselves sealed on assembly, with loctite sealant (grade 542) which should again be applied to the longer outer diameter and the adjacent face i.e. the portion which fits into the outer case sections. Examine the seals carefully and renew these if showing any imperfections.

Apply jointing compound to the joint surface of the left side crankcase section, lubricate the main

bearing and camshaft supports and refit the section to the centre crankcase. Replace eight bolts and plain washers (see Fig. B35).

“O” ring seals are fitted at the opening of the oil pump housing and in the chaincase. If these seals appear damaged in any way they must be renewed.

Apply jointing compound to the joint surface of the right side crankcase, position the camshafts so that the left end lobes point inwards, and lubricate the camshaft journals and roller main bearing. Refit the crankcase section, and replace two nuts and plain washers, five bolts and plain washers and two socket head screws (see Fig. B34).

SECTION B32

SERVICING THE CRANKSHAFT

Three screwed plugs should be removed from the crankshaft webs, (Fig. B37) to enable the crankshaft oilways to be blown clear. Removal of the right hand plug will enable the right big end journal and right centre main bearing to be cleared, and the centre and left hand plug enable the centre and left hand big end journal and also the left hand centre main bearing to be cleared.

The crankshaft assembly should be thoroughly washed in kerosene (paraffin) and any deposits on

the webbs removed with a wire brush. The complete assembly should be blown dry with an air line or vigorous use of a type pump, and the three oilway plugs replaced. These plugs should be secured with the aid of Loctite.

All crankshafts are dynamically balanced at the factory and no further balancing is required, even when oversize pistons are installed.

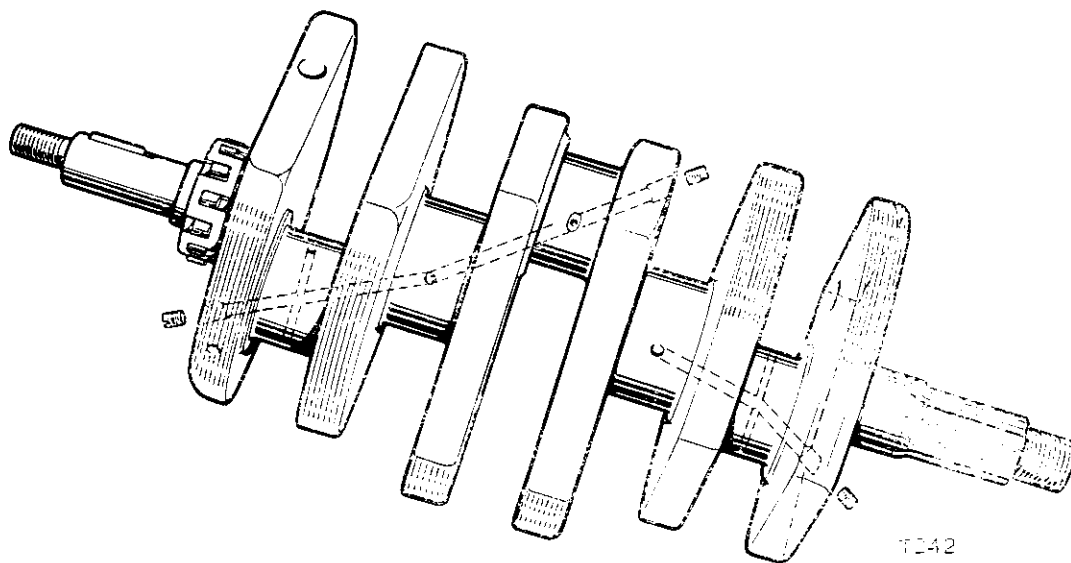


Fig. B37. Crankshaft oilways

SECTION B33

REFITTING THE CONNECTING RODS

First, ensure that the connecting rod and cap and both the front and rear of the bearings shells are scrupulously clean, then assemble the shells to the rod and cap and locating the shell tabs into their respective slots. Smear the bearing surfaces with engine oil and refit the rod and cap to their original

journals, ensuring that the tab location slots are adjacent to each other (see Fig. B38).

Replace the caps on the connecting rods with their center-punch marks on the same side.

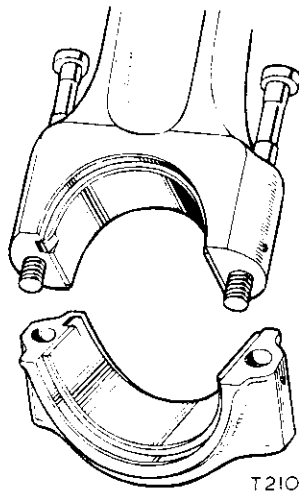


Fig. B38. Refitting a connecting rod

Refit the bolts and screw on the nuts, a turn at a time, and tighten the nuts to the torque figure given on page GD7, or in the absence of a torque wrench to the bolt extension figure given (see Fig. B39).

CONNECTING ROD
BOLT STRETCH
·003-·004 in.
[·0762-·1016mm]

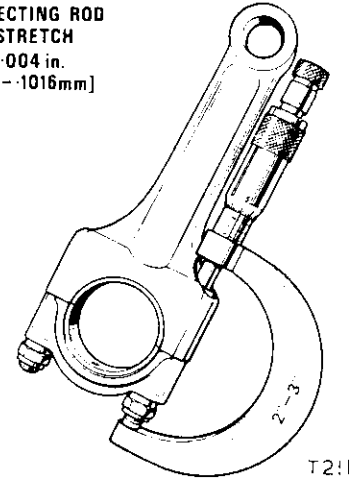


Fig. B39. Checking the bolt extension

SECTION B34

INSPECTING THE CRANKCASE COMPONENTS

In preparation for inspection, thoroughly clean the crankcase, main bearings, crankshaft and connecting rods, etc., in kerosene (paraffin) and allow them to drain. If there is an air pump accessible, then dry the components with a jet of compressed air and examine them as follows:—

(1) BIG-END & CENTER MAIN BEARINGS

The extent of wear to the bearing journals can be determined by inspecting the bearing surfaces for scoring, and by measuring the diameter of the journals with a micrometer. Light score marks can be reduced with smooth emery cloth, but ensure that all parts are carefully washed after this operation.

Where a journal has been only lightly scored, the shell bearings should be renewed. If the scoring and wear is extensive, the journals should be reground to a suitable size, as given below.

NOTE: The replaceable white metal shell bearings are pre-finished to give the correct diametral clearance. Under no circumstances should the bearings be scraped or the end cap joint faces filed.

BIG-END BEARINGS

Shell bearing marking	Suitable crankshaft size	
	in.	mm.
Standard:—	1·6235	41·237
	1·6240	41·250
Undersize:— —·010	1·6135	40·983
	1·6140	40·996
—·020	1·6035	40·729
	1·6040	40·742
—·030	1·5935	40·475
	1·5940	40·488
—·040	1·5835	40·221
	1·5840	40·234

CENTRE MAIN BEARINGS

Shell bearing marking	Suitable crankshaft size	
	in.	mm.
Standard:—	1.9170	48.692
	1.9175	48.705
Undersize: —010	1.9070	48.438
	1.9075	48.451
—020	1.8970	48.184
	1.8975	48.197
—030	1.8870	47.930
	1.8875	47.943
—040	1.8770	47.676
	1.8775	47.689

(2) MAIN BEARINGS

Clean the bearings thoroughly in kerosene (paraffin), then dry them with a jet of compressed air. Test the bearings for roughness by spinning. Check the center race for side-play and inspect the balls or rollers and tracks, for any signs of indentation and pooketing. Examine the main bearing diameters on the crankshaft, for wear. The bearings should be a tight push fit on the crankshaft and a press fit in the crankcase. A loose fitting bearing would

tend to cause crankcase "rumble". The correct diameters of the main bearing journals are given in "General Data", page GD2.

(3) CAMSHAFTS

The camshaft journals normally show very little sign of wear. If however the journals are suspect, they should be measured with a micrometer and compared with the dimensions given in GENERAL DATA, page GD3.

Wear on the cam form will be mainly centered on the opening flank of the cam and on the lobe of the cam. Particular attention should be given to these areas when examining the cam form for grooving. In a case where there is severe grooving, the camshaft and tappet followers should be renewed.

A method of estimating the extent of wear on the cam form is that of measuring the over-all height of the cam and the base-circle diameter, see page GD4. The difference is the cam lift. If all other aspects of the camshaft are satisfactory and the wear on the cam form does not exceed 0.010 in., then the camshaft may be used for further service.

(4) CRANKCASE FACES AND DOWLS

Ensure that all faces are clean, free from burrs and traces of jointing compound, or gasket. Any small scratches etc. can be removed with a fine file. Ensure that all dowels are in position and undamaged. Any suspect dowel should be replaced.

SECTION B35

RENEWING THE MAIN BEARINGS

To remove the left side ball bearing, remove both retaining circlips with the aid of a pair of circlip pliers. Heat the crankcase section to approximately 100°C. (boiling water) and drive the bearing out using service tool 61-6021. See Figs. B40 and B41.

To assemble the new bearing, ensure that the bearing housing is clean and grease free, and that

the outside of the bearing is also grease free. Reheat the crankcase, and apply a small amount of Triumph Loctite to the bearing. Refit either one of the retaining circlips, and drive the bearing in from the opposite side, ensuring that it enters squarely. If possible, use a press for this operation. When the bearing is correctly positioned, replace the second circlip.

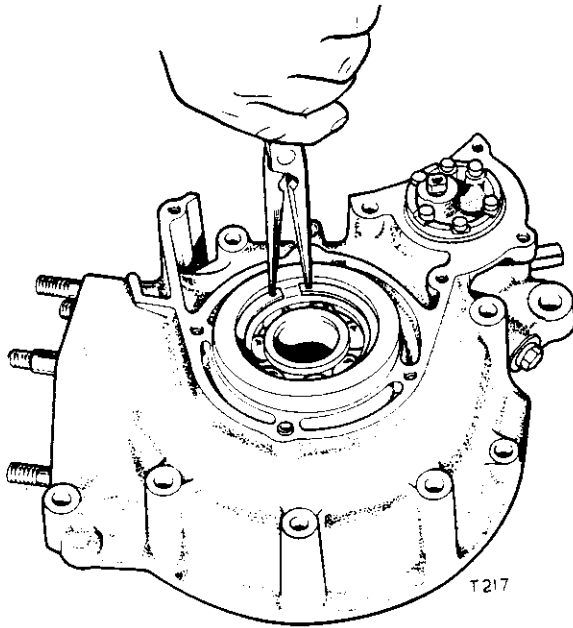


Fig. B40. Removing a circlip

The right side bearing is a roller type, and the inner portion is withdrawn with the crankshaft.

To remove and replace the outer race, employ the procedure previously described for the left bearing, but using service tool 61-6020.

The inner portion should be extracted from the crankshaft with the aid of service tool No. 60-3677. See Fig. B42 and replaced with a hollow drift. A small amount of Triumph Loctite should be applied to the crankshaft before refitting the inner portion.

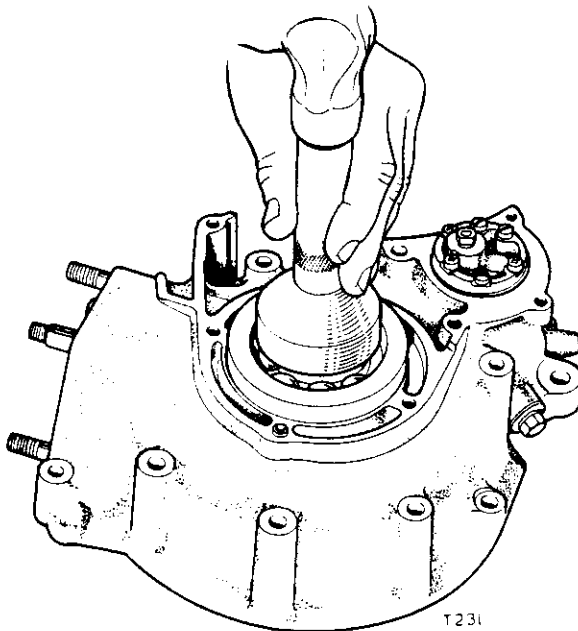


Fig. B41. Replacing a bearing

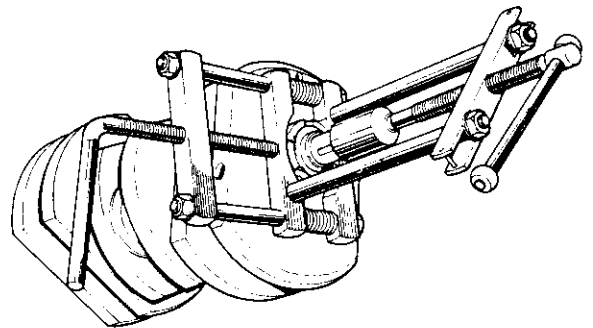


Fig. B42. Extracting right side bearing inner spool

To replace the centre bearing shells, they should be gently lifted away from either the bearing caps or crankcase supports. Use a small screwdriver, and lift each shell from beneath the locating tab. Ensure that each cap and support is clean, and refit the new shells, taking care to ensure that the tabs are located correctly in the machined slots.

SECTION B36

REMOVING AND REPLACING THE TACHOMETER DRIVE

The tachometer gearbox (which transmits the drive to the instrument through 90°) is mounted on the left side crankcase. The gears are driven by the

exhaust camshaft, a tongue on the driving gear locating in a slot at the end of the camshaft.

To dismantle, first disconnect the cable drive above the gearbox. Note that this cable has a tongued end which registers in the slotted end of the driven gear.

Remove the end cap A (Fig. B43) with its sealing ring, and extract the driving gear with the aid of a pair of thin-nosed pliers.

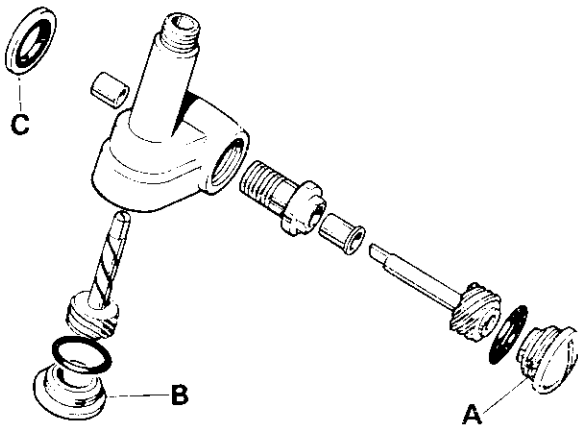


Fig. 43. Tachometer order of assembly

Now remove the end cap B together with its seal, and withdraw the driven gear.

If the main body is to be removed, insert a thin-walled 7/16 in. A/F tubular wrench through the driving gear aperture and unscrew the securing sleeve. **This has a left hand thread** and unscrews

by turning clockwise. The oil seal C between the gearbox and the crankcase will also be released.

Check all these seals for damage, renewing as necessary.

Wash all parts thoroughly in kerosene (paraffin) and examine the gear teeth for excessive wear, and the tongue or slot on the gear shafts for damage.

The bushes in the securing sleeve should be checked for wear in accordance with the dimensions given on page GD3.

If they are to be renewed, note that one bush has a 'head', and hence the bushes must be driven out from the opposite end. A shouldered drift is advisable for re-assembly.

The driven gear (i.e. the one attached to the cable) runs direct in the gearbox body. Wear, indicated by an excessive amount of sideways movement, can be rectified only by renewal of either, or both, components.

When re-assembling, place the oil seal in position between the gearbox and the crankcase, and tighten the securing sleeve (remember that it has a left hand thread), at the same time aligning the driven gear shaft with the cable. Insert the driving gear and make sure that its tongued end is properly engaged with the slot in the camshaft.

Replace the end-cap and oil seal. The driven gear, with its end-cap and seal is replaced next. Note that its shaft will be seen to rotate slightly as the two gears engage.

When connecting the cable, make sure that its tongue is properly located in the driven gear shaft before tightening its securing nut.

Both gears and the interior of the gearbox housing should be liberally coated with grease before assembly. Recommended lubricants are given on page A5.

SECTION C

PRIMARY DRIVE

DESCRIPTION	Section
DESCRIPTION OF PRIMARY DRIVE	C1
CLUTCH	C2
ADJUSTING CLUTCH OPERATING MECHANISM	C3
ADJUSTING PRIMARY CHAIN	C4
REMOVING AND REPLACING THE OUTER PRIMARY CHAINCASE COVER	C5
REFITTING THE CLUTCH COVER	C6
STRIPPING PRIMARY DRIVE	C7
REASSEMBLING PRIMARY DRIVE	C8
PRIMARY CHAIN SPROCKET ALIGNMENT	C9
REFITTING THE INNER PRIMARY CHAINCASE	C10
RENEWING SHOCK ABSORBER RUBBERS	C11
REMOVING AND REPLACING THE CHAINWHEEL AND ENGINE SPROCKET	C12
INSPECTION OF PRIMARY DRIVE COMPONENTS	C13
REAR CHAIN ALTERATIONS AND REPAIRS	C14

SECTION C1

PRIMARY DRIVE

The engine unit transmits its power output from the crankshaft sprocket by a duplex chain to the clutch chainwheel, via a vane type shock absorber, to a single-plate, diaphragm-spring clutch. Hence the power is delivered through the transmission to the final drive sprocket and, in turn, by a heavy duty

chain to the rear sprocket and wheel. The purpose of the clutch is to provide the means of disconnecting the flow of power from the engine to the rear wheel. It is not necessary to remove the engine unit to carry out work on the primary drive.

SECTION C2

CLUTCH

CLUTCH DESCRIPTION

A cast iron drive ring bolted to a pressed steel cover encloses a driven plate, a cast iron pressure plate, and a diaphragm spring. The latter applies the clamping load to the pressure plate. The drive ring also carries the starter ring gear.

The clutch is released by a pull rod, acting on a ball bearing in the centre of the pressure plate. This separates the two friction surfaces, and allows the driven plate to revolve freely between them. There is no need to "free" the clutch before starting the engine.

MAINTENANCE

The only maintenance necessary is adjustment of the clutch pull rod, (Section C3). Whenever the

primary chain is removed, (see sections C7, C8) it may be advantageous to examine the clutch facings at the same time, to ensure that undue wear has not occurred, because considerable work is otherwise entailed in gaining access to these parts. No attempt should be made to lubricate any part of the clutch unless it is completely dismantled, since there would be a risk of oil contaminating the facings. If clutch slip or drag is noticed, first check that the pull rod is not binding. If this is satisfactory, it will be necessary to strip the clutch and make replacements.

Note:-

Should the motorcycle be driven under conditions of continued slip, the heat generated could cause considerable damage to the clutch unit.

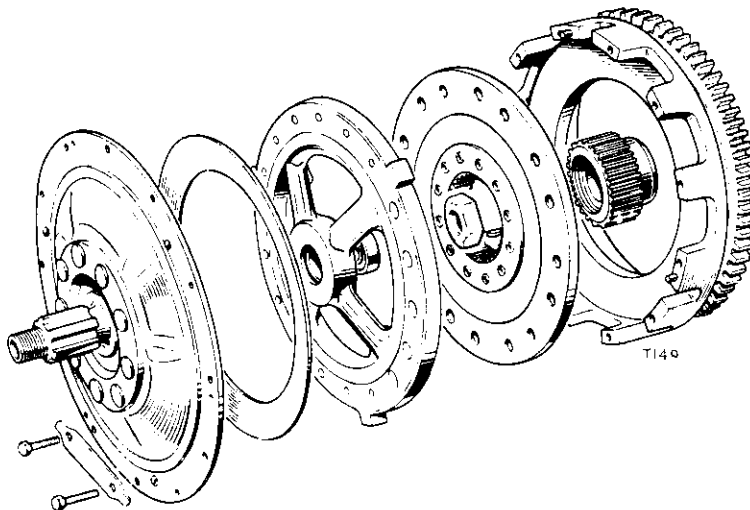


Fig. C1. Exploded view of clutch

SECTION C3

ADJUSTING THE CLUTCH OPERATING MECHANISM

Remove the inspection plate and gasket from the outer primary chaincase, to allow access to the clutch operating mechanism.

Very little movement is required in the clutch pull rod to disengage the friction plate; there must be a clearance of approx. 0.002 in. between the rear face of the large adjuster nut and the ball bearing in the actuating plate. If too much clearance is allowed, then it may be found impossible to disengage the clutch. On the other hand, if excessive clearance is present, the clutch friction plate will constantly slip, and will eventually burn out.

ADJUSTMENT

Withdrawal of the footrest rubber simplifies removal of the inspection cover 'A' Fig. C3, which provides access to the clutch operating mechanism. Completely slacken off the cable adjuster at the handlebar and also at the chaincase at 'A' Fig. C2. Extract the cable from the handlebar lever.

Hold the sleeve nut M and release the small locknut R. Still holding the nut M stationary, unscrew the operating rod P with a screw-driver until the clearance between the rear-face of the sleeve nut and the thrust bearing (behind the nut) is only just taken up, i.e. the rod P has no end-play.

Re-assemble the cable, which must then have all slackness removed by means of adjuster A. (Fine adjustment only, is provided at the handlebar). Now screw-in the rod P just sufficiently to give a

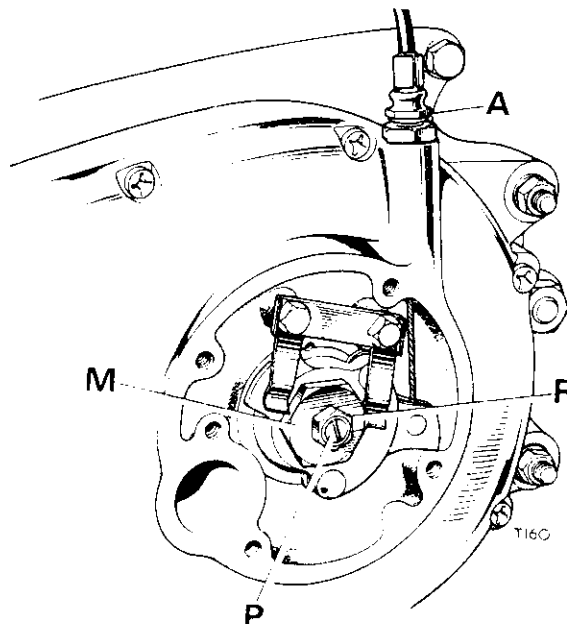


Fig. C2. Showing clutch adjustment

trace of end play (0.002 in.) (0.012 mm) and tighten locknut R. This end-play is essential and will give the correct amount of cable slackness at the handlebar.

Adjustment of the clutch operation must not be made by means of the cable only. The above sequence of instructions must always be followed. Take the greatest care during any minor cable adjustment at the handlebar, that in the process, the clutch is not partially freed.

SECTION C4

ADJUSTING THE PRIMARY CHAIN

The primary chain is of the duplex type, and is non-adjustable, since the centres of the engine mainshaft and transmission mainshaft are fixed. Provision for take-up of wear in the chain is made by means of a rubber faced slipper blade, pivoted below the lower run of the chain. The free movement in the chain can be felt with the finger, after removing the slotted inspection plug from the chaincase, with the ENGINE STOPPED.

To adjust, first apply pressure to the starter pedal by hand, to remove all slackness from the bottom run of the chain, when there should be approx. $\frac{3}{16}$ in. (5 mm) of free play in the top run. Fig. C3.

To reduce excessive slackness, remove the sealing cover A, release the locknut B, and screw the

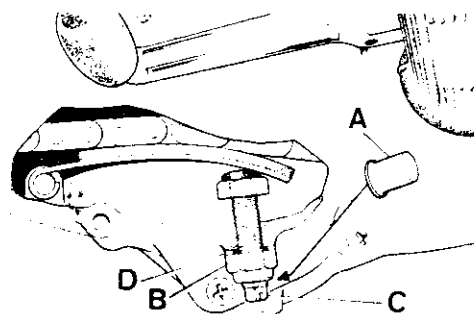


Fig. C3. Primary chain adjustment

adjuster C inwards until the correct chain slackness is obtained. Re-tighten the self-locking nut B. Note that the washer D incorporates a special oil seal which must be renewed in the event of leakage.

It is most important that the chain should not be tight.

When adjustment is completed, replace the slotted inspection plug.

SECTION C5

TO REMOVE AND REPLACE THE OUTER PRIMARY CHAINCASE COVER

Position a suitable receptacle beneath the centre of the outer chaincase, and drain the case by removal of the plug (lower centre of the inner chaincase). Take off the left footrest by removing the large bolt and washer from behind the left side rear engine plate. Slacken the primary chain adjuster, to release any pressure from the lower run of the chain (See Section C4).

Remove five cross head screws from the clutch operating mechanism inspection cover, and take off the cover complete with gasket. Remove the clutch pull rod adjuster locknut, followed by the large nut. It will be necessary to hold the latter with a suitable wrench, before the locknut can be released.

Slacken the clutch cable adjustment at both the handlebar and chaincase ends, and release the lower nipple from the operating mechanism. Unscrew the cable adjuster from the chaincase, and lift clear.

Removing the Clutch Operating Mechanism

Straighten the tab washer from the two retaining bolts for the spring blades, remove both bolts, and collect the tab washer, springs, and spacers. Lift the clutch lever assembly clear, collecting the three ball bearings. The thrust plate is now free to be removed.

Examine the balls and tracks for pitting and corrosion, also check the release bearing for wear, renewing parts as necessary.

To re-assemble, place the thrust plate in position on the chaincase, noting that the notch must fit over the locating peg. Smear grease in the ball grooves, and use this to secure the balls in position whilst the operating lever (complete with bearing) is placed in position, with the cable arm in the horizontal position. Using a new tab washer, refit the spring blades and spacers, and fit and secure the bolts.

THE OUTER CHAINCASE

To take off this item, it will be necessary to remove the clutch operating mechanism, as described earlier in this Section. Remove nine cross head screws, and three countersunk screws from the chaincase, (See Fig. C4).

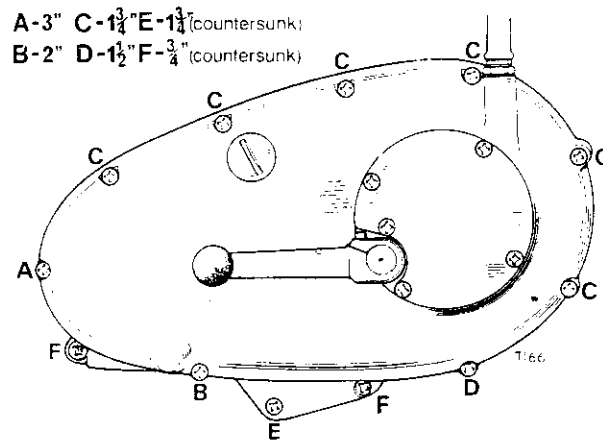


Fig. C4. Showing outer chaincase screw location

The cover is now free to be removed, although it may require a light tap with a hide mallet to break the joint. The gear shift lever assembly will remain with the cover as it is withdrawn i.e. in neutral position. Prepare the chaincase for refitting by removing all traces of the joint washer, and ensure that both faces are clean and free from burrs. Ensure that both tubular locating dowels are fitted into the two counter-bored screw holes on the inner chaincase, grease the joint surface, and position the gasket. Assemble the cover, with care, over the oil pump idler spindle, clutch pull rod, and locating dowels. Make sure that the quadrants on the gearshift spindle and the cross shaft are correctly engaged with gear pedal still in neutral position, otherwise the gearshift sequence will be incorrect.

Refit the remaining screws (See Fig. C4 for correct positions). Tighten the screws in a diagonal pattern to avoid distorting the chaincase. Turn the clutch operating lever clockwise, until its arm contacts its "stop" boss in the housing, then, for correct adjustment of the mechanism, refer to Section C3. Refer to Section C4 for adjusting the primary chain.

Refit the footrest, securing firmly with the large washer and bolt. Finally add $\frac{3}{4}$ U.S. pint of the recommended grade of lubricant (See Section A2).

SECTION C6

REFITTING THE CLUTCH COVER

(For removal, see Section C7)

Check that the oil seal in the centre of the cover is not cut, or otherwise damaged. If it is necessary to renew the seal, drive it out using a shouldered drift, and tap the new seal into position, lip towards the gearbox, and level with the outer boss of the cover.

Ensure that the joint surfaces are clean, and tap the clutch gently home to the crankcase with a hide hammer, until the spigot on the cover locates in the crankcase recess. Fit and tighten up the three screws.

SECTION C7

DISMANTLING THE PRIMARY DRIVE

(To gain access to the clutch)

Before commencing operations, engage a gear as an aid to releasing various nuts. Remove the outer primary chainscase and associated fittings (See Section C5) and collect the needle roller thrust bearing from the centre of the chainwheel. Note the order of bearings and washers. Remove the gearshift quadrant from the crossshaft, following release of the self locking nut. Straighten the washer which secures the engine sprocket nut, and remove this, using a tabular wrench, tommy bar and hammer. There is no tab washer under the chainwheel nut, but before attempting removal, cover the threads of the clutch pull rod with a strip of sellotape, to prevent damage to the oil seal on removal. Both sprockets are then ready for withdrawal. Note that the sprockets and primary chain must be removed as a set, because the chain is "endless" i.e. it is not fitted with a connecting link, and hence cannot be removed independently (See Section C12). Carefully preserve the shims removed from behind the engine sprocket.

Straighten the tab washer and remove the nut holding the oil pump drive gear to the pump spindle. Take off the gear which is located on a taper diameter, and will require the use of universal extractor set 61-3808. The outrigger bearing for the cross shaft must next be dismantled. Straighten the tab washer and unscrew the two set pins which will release the bearing, spacing sleeve, and locating plate, all of which can be then withdrawn. Do not disturb the pinion on the crankshaft, but draw the intermediate idler gear off its spindle.

Remove the long bolts securing the inner chain case to the crankcase, together with all the screws, when the chaincase is free to be removed. The clutch is now exposed. This is a sliding fit on the splines of the clutch hub, and can be withdrawn complete with pull rod.

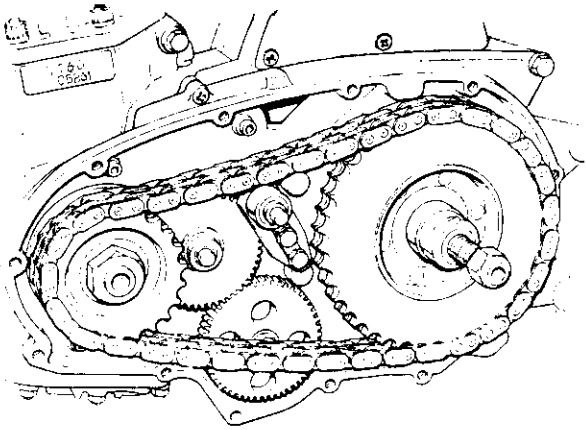


Fig. C5. Removing clutch shock absorber

The clutch hub nut then requires removal with a tubular wrench, tommy bar, and hammer. The clutch hub is keyed and tapered to the transmission mainshaft, and can only be removed using extractor 60-860 which screws into the end of the splined hub. The clutch cover is secured by three screws only, after removal of which, it can be lifted clear. The breather duct cover and gasket are secured to the clutch-cover with four screws.

SECTION C8

REASSEMBLING THE PRIMARY DRIVE

Refit the clutch cover (See Section C6). Fit the oil pump drive gear onto the crankshaft, shouldered side inwards, and, if necessary, tap home as far as the main bearing inner race.

Fit the clutch splined hub (shouldered side inwards) onto the mainshaft, add, and securely tighten, the nut, using a torque wrench (See page GD8). To prevent the shaft turning, engage a gear (preferably bottom) and hold the rear brake fully on. Grease the splines lightly with Shell grease SP2628, and replace the clutch assembly, complete with pull rod. The clutch must be free to move to and fro on the splines.

Replace the inner primary chaincase (See Section C10). Fit the oil pump gear to the taper on the pump spindle, and tighten the nut securing afterwards with the tab washer. Lubricate and place the idler gear (boss outwards) over the spindle, meshing with the crankshaft and oil pump gears.

Replace the chainwheel assembly on the clutch shaft, and the engine sprocket on the crankshaft, without the chain, if necessary using a hammer and hollow drift to drive both fully home on the

splines. Now align the sprockets as described in Section C9.

When alignment is correct, remove the sprockets with the appropriate extractor, leaving any shims in position, and fit both sprockets into the primary chain. Assemble the sprockets and primary chain as a unit to the shafts, driving the sprockets home on the splines if necessary. Fit a new engine sprocket tab washer, locating the internal tab into one of the sprocket splines. Add the nut, and tighten securely using a torque wrench (See page GD8), and lastly, peen the locking tab onto the nut.

At the chainwheel, the centre nut is fitted with a small garter oil seal, which will be damaged unless extreme care is taken. Before fitting the nut and seal over the clutch pull rod, ensure that the thread of the pull rod is protected by a strip of sellotape, and as the nut is pushed and screwed home the seal will not be damaged. Secure the centre nut. Oil lightly, and fit the needle roller thrust bearing over the chainwheel centre boss.

Replace the gearshift outrigger bearing and the quadrant on the cross-shaft. Take care to fit the quadrant the correct way round, (See fig. C5) and ensure that the gear is in the neutral position. Retain the set screws with their tab washer.

SECTION C9

PRIMARY CHAIN SPROCKET ALIGNMENT

It is essential that the primary chain misalignment does not exceed 0.010 in.

Owing to the design of the primary transmission, the engine and shock absorber sprockets cannot be accurately aligned with the customary use of a straight edge, unless used in conjunction with a cutaway primary outer cover (Fig. C6).

Normal manufacturing tolerances, which apply to the inner and outer primary covers, and all other components from which the shock absorber is constructed, create a variation in the amount of shock absorber end-float. Since operation of the clutch presses the shock absorber assembly against its thrust bearing, the end float present in each particular engine unit must be eliminated before checking the alignment.

If either of the primary covers, or any component part of the shock absorber, is changed for any reason, the amount of end-float will almost certainly alter. It is also necessary to account for variations in the thickness of the primary cover gasket.

Sprocket alignment must be checked without the chain in position.

Replace the engine sprocket, together with any shims formerly fitted between the sprocket and the oil pump drive gear behind it. Drive the sprocket home with a tubular drift.

Carefully clean the joint face of the inner cover and add the gasket.

Replace the chainwheel assembly onto the clutch shaft splines and then fit the needle roller thrust bearing to the inner face of the chainwheel.

At this stage, the cutaway outer primary chaincase is necessary. As shown in Fig. C6 the cover requires only three equally spaced fixing holes and the needle roller bearing and thrust washer in situ. The remainder of the cover can be cut away.

Pull the shock absorber chainwheel to abut to the cutaway chaincase and hold in this position.

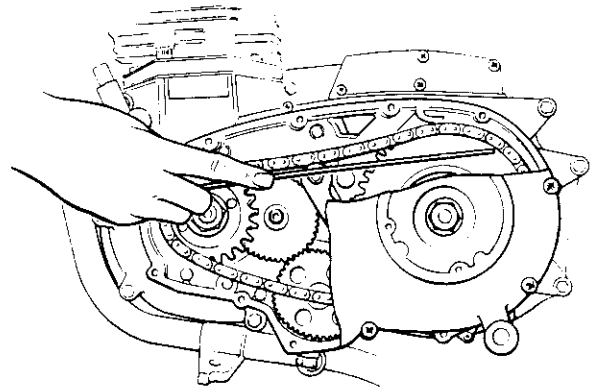


Fig. C6. Cutaway outer primary cover

Lay a steel straight edge, about 12 inches long, across the face of the chainwheel (**not** across the central boss) and check against the face of the engine sprocket. If re-alignment is necessary, remove the engine sprocket with the Service tool as shown in illustration Fig. C7, and add (or extract) shims of appropriate thicknesses behind the sprocket. Again, drive the sprocket home and make a final check of the alignment.

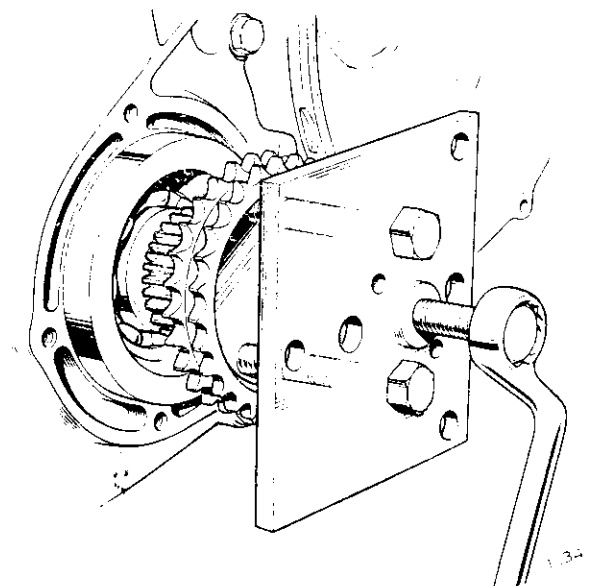


Fig. C7. Extracting the engine sprocket

Remove the cutaway cover, withdraw the chain-wheel assembly, and take off the engine sprocket (Fig. C7).

Assemble the primary chain to both sprockets and replace as a unit. It is essential that the two sprockets are fitted simultaneously and that the chain is kept straight during the whole operation.

Tighten the engine sprocket securing nut, using a new locking washer.

Replace the spacer on the clutch mainshaft, and then the securing nut, having first verified that the oil seal is in good condition. Ensure that the seal is not damaged by the thread on the pull rod. A strip of sellotape should be used, as previously mentioned in Section C7.

For torque settings for both engine sprocket and clutch mainshaft see page GD 8.

SECTION C10

REFITTING THE INNER PRIMARY CHAINCASE

Removing the inner primary chaincase is covered in Section C7, but the additional following information is required during reassembly.

Clean all traces of old joint washer and jointing compound from both joint surfaces. Next examine the clutch shaft oil seal for cuts or other damage. The old seal can be prised out with a screwdriver—this, of course, destroys the seal. A new seal should then be fitted, with the spring side inserted first. Tap in evenly as far as possible, a little at a time with a light hammer.

If the needle race needs replacing, use a shouldered drift to knock out both the race and seal together. Fit the new race flush with the outer surface, and tap in the seal from the back.

Check the condition of the gearshift cross shaft bearing (needle roller) and of the oil seal adjacent to it. These are mounted in a common housing. A new seal should be fitted with its lip outwards.

Examine the 'O' ring surrounding the oil pump (fitted in the chaincase aperture), renewing as necessary.

When the inner primary case is replaced, fit a new gasket over the crankcase joint surface, greasing this lightly to retain it.

Tap the cover home with a hide hammer, until the spigot on the clutch cover locates to the back of the case. Take great care not to trap the pump O' ring, otherwise the cover must be removed again and the seal renewed.

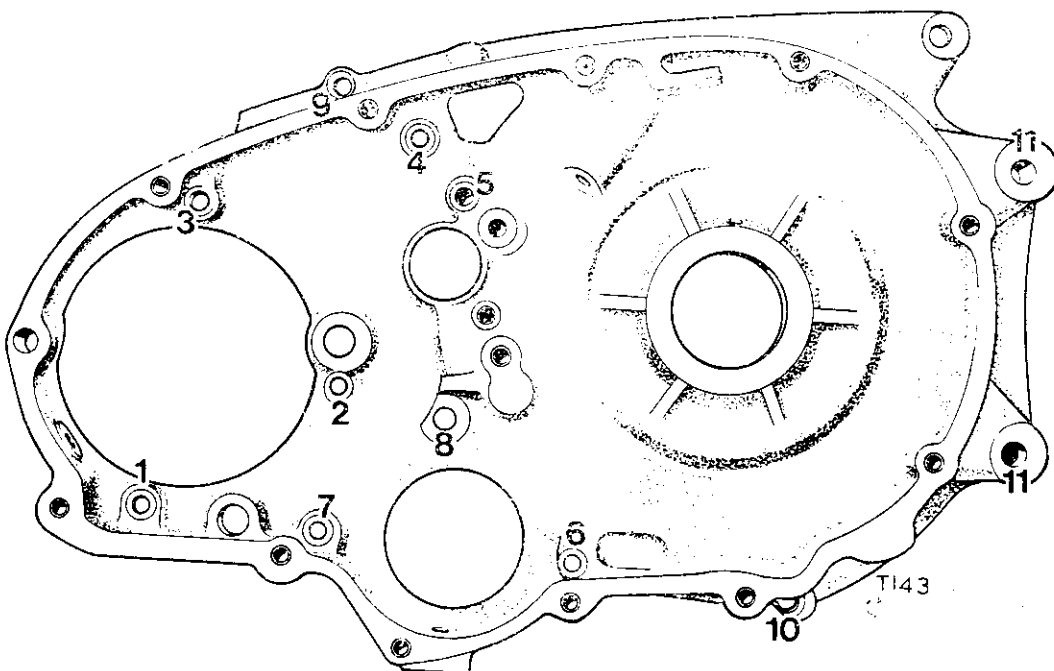


Fig. C8. Items 1-7 socket head screws, 8—hexagon headed bolt ($4\frac{1}{2}$ in. UH), 9 and 10 cross-headed screws, 11—bolts to engine plate, 12—hexagon headed bolt ($4\frac{1}{2}$ in. UH)

Straighten the tabs of the locking plates and remove the six bolts retaining the outer plate. After the screws are removed, the plate can be lifted off and the rubber segments exposed. At this stage, the hexagon portion of the leverage bar should be placed in the splines of the shock absorber spider. A strong pull on the bar will then rotate the spider, and compress one set of rubbers. The bar will be held in this position by inserting a screwdriver blade or a tommy bar through the hole in the bar to engage with the sprocket teeth. The first set of rubbers can then be lifted out. Carefully restrain the bar whilst the screwdriver blade is withdrawn. At this stage the remaining sets of rubbers will be free for removal, and the spider can be lifted out.

One type of rubber is used for both drive and rebound. Fit the new rubbers into place, using the mounting jig and bar. Then fit the retaining plate, followed by the locking plates and the bolts, securing these with the tabs of the locking plates.

When the assembly is completed, the shock absorber unit should be tested as follows:-

Apply a counter-clockwise torque to the chainwheel, while the inner splines of the spider assembly are held stationary. Angular deflection should be in accordance with the figures in the table.

Torque	Deflection
40 lb. ft.	2—4
70 lb. ft.	3½—6
100 lb. ft.	4½—6
130 lb. ft.	5—8½

SECTION C12

REMOVING AND REPLACING THE CHAINWHEEL AND ENGINE SPROCKET

Remove the outer primary chaincase as described in Section C5. The gear shift quadrant must be taken off the cross shaft on which it is located by two 'flats', and retained by a self locking nut and washer. Straighten the engine sprocket nut tab washer, and remove the nut (a tubular wrench a tommy bar, and hammer, will be needed). Renew the tab washer when reassembling.

Using sellotape to protect the clutch pull rod thread, remove the retaining nut and plate washer from the centre of the chainwheel. It is preferable to leave the sellotape in position, because this will facilitate replacement.

It will be necessary to withdraw the chainwheel, chain and engine sprocket simultaneously from their splined shafts, using extractor 61-6046 for the engine sprocket, as shown in Fig. C7.

Assemble the engine sprocket extractor 61-6046, and screw in the centre bolt to extract the engine sprocket.

The sprockets complete with the chain can then be lifted clear as a unit, and the sprockets separated from the chain. Thoroughly clean all the parts in kerosene (paraffin) and inspect them for wear or fatigue.

To reassemble, note that the engine sprocket fits with the boss towards the main bearing. It will be necessary to fit the chainwheel, engine sprocket and primary chain as a set, aligning the splines so that the set can be pushed home. If necessary, tap the sprockets home with a hide mallet and then fit the tab washer and nut at the engine sprocket, tapping the tab carefully into position after securing the nut.

Refit the washer and nut to the chainwheel tighten the securing nut fully.

Oil lightly and fit the thrust needle roller bearing. The outer primary chaincase should now be fitted as in Section C5, and the clutch adjusted (See Section C3).

SECTION C13

INSPECTION OF PRIMARY DRIVE COMPONENTS

- (1) Inspect the primary chain for excessive wear of the rollers and pivot pins, and check that the elongation does not exceed $1\frac{1}{2}\%$. To do this, first scribe two marks on a flat surface exactly 14 in. (35.5 cm.) apart, then after degreasing or washing the chain in kerosene (paraffin), place the chain opposite the two marks. When the chain is compressed to its minimum free length the marks should coincide with the centres of two pivot pins 32 links apart. When the chain is stretched to its maximum free length the extension should not exceed 0.2 ins. (6.25 mm.).

Inspect the condition of the sprocket teeth for signs of hooking and pitting.

A very good method of indicating whether the chain is badly worn or not is to wrap it round the chainwheel and attempt to lift the chain from its seating at various points around the sprocket. Little or no lift indicates that both the sprocket and chain are in good condition.

If the engine sprocket is a tight fit on the crankshaft, there is no cause for concern, as such a fit is to the best advantage.

- (2) Check the fit between the shock absorber spider and the clutch shaft splines. The spider should be a push fit onto the splines and there should not be any rotary movement.

Similarly check the fit of the engine sprocket splines on the crankshaft. Again there should not be any rotary movement.

- (3) Check that the shock absorber spider is a good working fit in the inner and outer retaining plate and that the arms of the spider have not caused excessive score marks on the inner face of the housing. Check the working clearance by assembling the shock absorber unit without the rubbers.

SECTION C14

REAR CHAIN ALTERATIONS AND REPAIRS

If the chains have been correctly serviced, very few repairs will be necessary. Should the occasion arise to repair, lengthen or shorten the chain, a rivet extractor, as shown in Fig. C12, and a few spare parts will cover all requirements.

replace by a single connecting link and inner link as shown in (4).



To shorten a chain containing an even number of pitches, remove the dark parts shown in (1) and replace by crank double link and single connecting link as shown in (2).



To repair a chain with a broken roller or inside link, remove the dark parts shown in (5) and replace by two single connecting links and one inner link as shown in (6).



To shorten a chain containing an odd number of pitches remove the dark parts shown in (3) and

Fig. C11. Rear chain alterations

The rivet extractor Fig. C12, can be used on all motorcycle chains up to $\frac{3}{4}$ in. pitch whether the chains are on or off the chain-wheels.

When using the extractor:—

- (1) Turn screw anti-clockwise to permit the punch end to clear the chain rivet.
- (2) Open the jaws by pressing down the lever (see below).
- (3) Pass jaws over chain and release the lever. Jaws should rest on a chain roller free of chain link plates (see below).
- (4) Turn the screw clockwise until the punch contacts and pushes out the rivet end through the chain outer link plate. Unscrew the punch, withdraw the extractor and repeat the complete operation on the adjacent rivet in the same chain outer link plate. The outer plate is then free and the two rivets can be withdrawn from opposite sides with the opposite plate in position. Do not use the removed part again.

When the alterations are finished the chain should be lubricated as shown in Section A2.

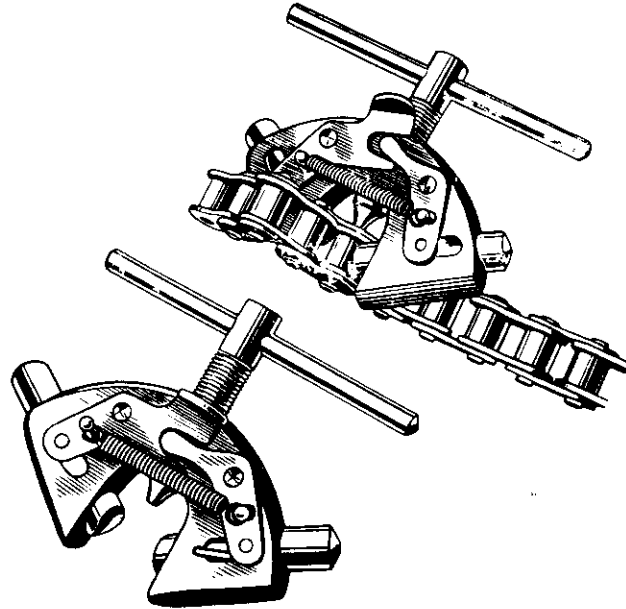
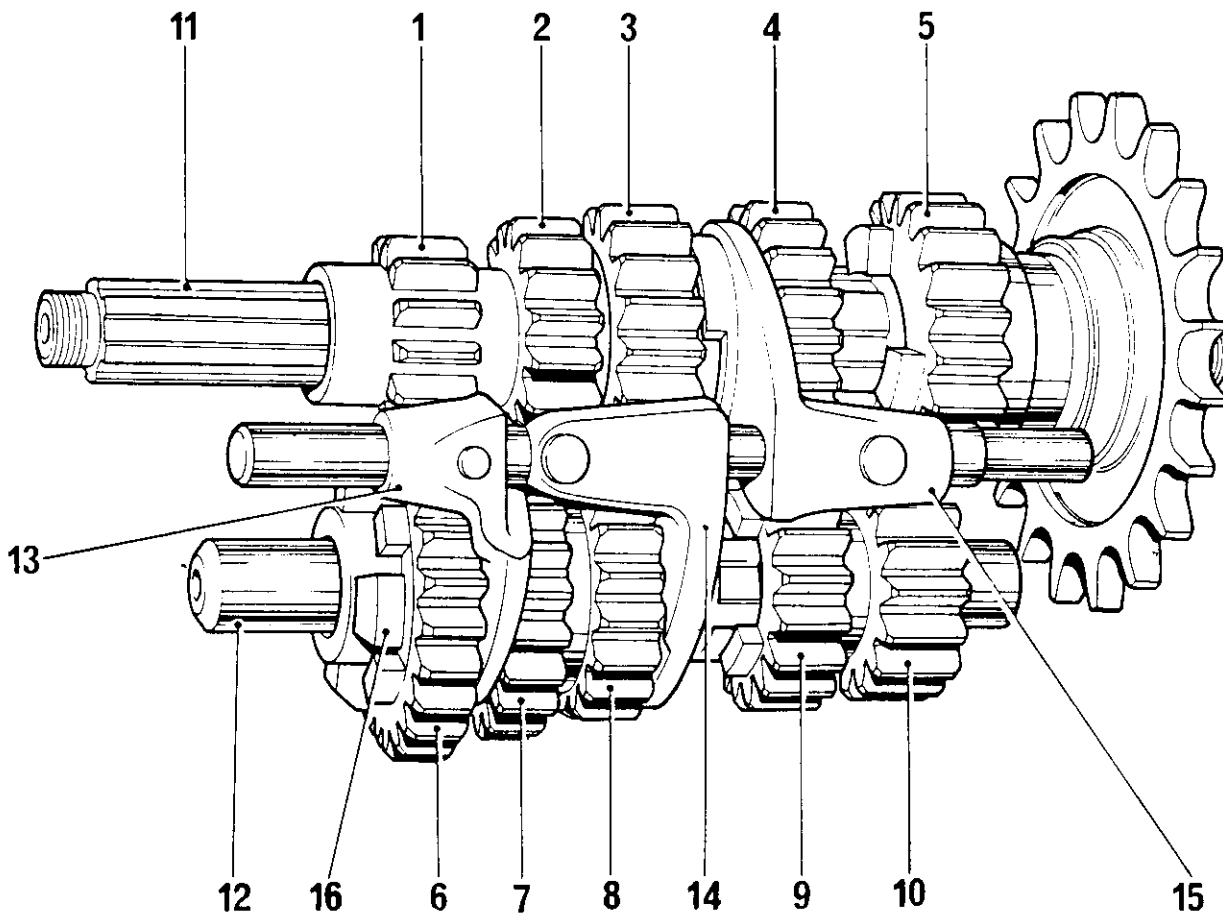


Fig. C12. Chain link rivet extractor,

SECTION D

TRANSMISSION (GEARBOX)

DESCRIPTION	Section
SEQUENCE OF GEAR SHIFTING	D1
REMOVING AND REPLACING THE OUTER COVER ASSEMBLY	D2
DISMANTLING AND REASSEMBLING THE KICKSTART MECHANISM	D3
DISMANTLING AND REASSEMBLING THE GEAR SHIFT MECHANISM	D4
DISMANTLING AND REASSEMBLING THE GEAR SHIFT CROSS SHAFT	D5
INSPECTING THE GEAR SHIFT AND KICKSTART COMPONENTS	D6
RENEWING KICKSTART AND GEAR SHIFT SPINDLE BUSHES	D7
DISMANTLING THE TRANSMISSION (GEARBOX)	D8
INSPECTION OF THE TRANSMISSION (GEARBOX) COMPONENTS	D9
RENEWING MAINSHAFT AND LAYSHAFT BEARINGS	D10
REASSEMBLING THE TRANSMISSION (GEARBOX)	D11
CHANGING THE TRANSMISSION (GEARBOX) SPROCKET	D12



- | | |
|----------------|---------------------------------------|
| 1. LOW GEAR | 9. FOURTH GEAR |
| 2. SECOND GEAR | 10. FIFTH GEAR |
| 3. THIRD GEAR | 11. MAINSHIFT |
| 4. FOURTH GEAR | 12. LAYSHIFT |
| 5. FIFTH GEAR | 13. FIRST GEAR LAYSHAFT SELECTOR FORK |
| 6. LOW GEAR | 14. THIRD GEAR LAYSHAFT SELECTOR FORK |
| 7. SECOND GEAR | 15. MAINSHAFT SELECTOR FORK |
| 8. THIRD GEAR | 16. LAYSHIFT ENGAGING DOG |

Fig. D1. Plan of Gear components

SECTION DI

SEQUENCE OF GEARSHIFTING

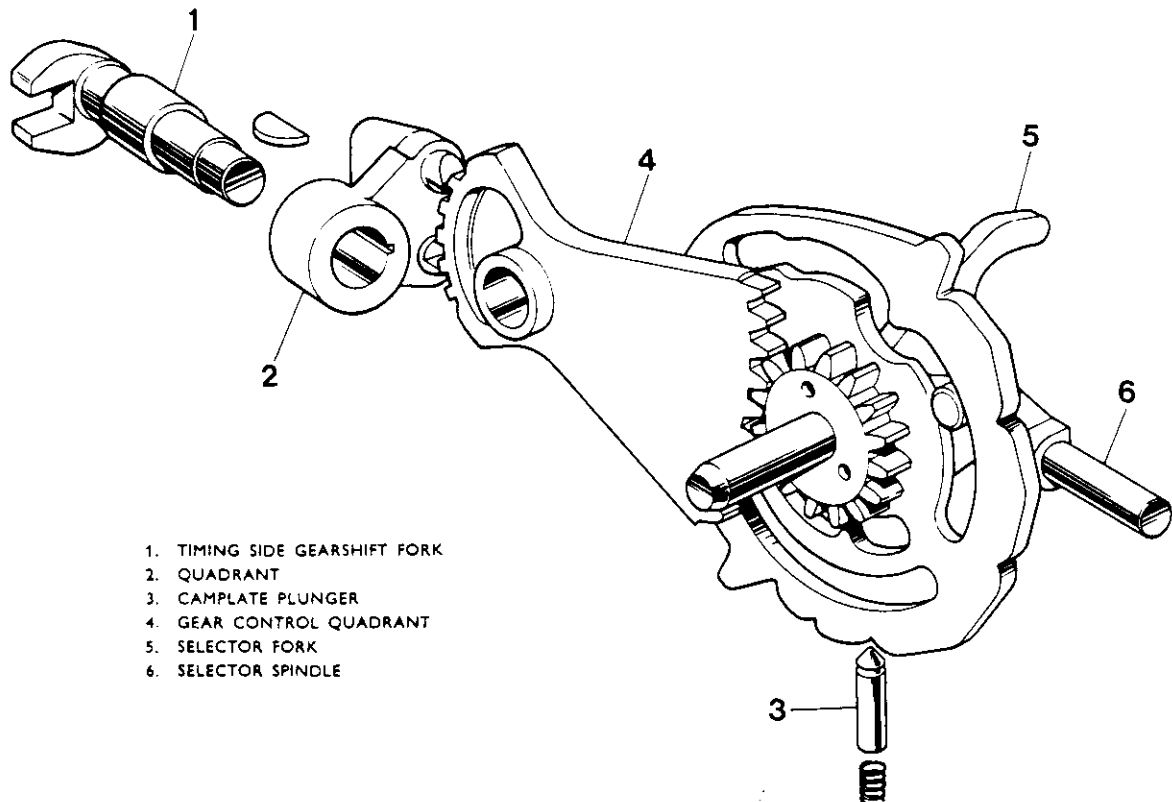
The gearshift is operated by the pedal on the left side of the machine, the pedal being splined to the gearshift spindle, with which is combined the plunger housing. The two spring loaded plungers project from the housing, so that, as the gear pedal is moved up and down, the plungers locate in the teeth at the outer end of the quadrant. This is pivoted in the centre and the inner teeth engage with the captive pinion on the camplate. See Fig. D2.

Figs. D3(i) to D3(vi) illustrate the camplate with its plunger, and the engaging pins of the selector forks which can be seen in the camplate tracks. The three sliding pinions are moved along the mainshaft and layshaft by the selector forks. The neutral positions of the camplate and gears are shown in Fig. D3(ii).

When the pedal is depressed to engage low gear (first), the camplate is turned anti-clockwise, moving the layshaft selector fork to mesh the sliding first gear with the dog-lock on the end of the layshaft. (The dog-lock is illustrated in Fig. D1).

As second gear is selected by lifting the pedal, the second layshaft selector fork brings the sliding third gear into mesh with the layshaft second gear, while the previous selector fork disengages first gear from the dog-lock.

Movement of the gear lever in the same direction will select third gear by moving the mainshaft sliding gear into mesh with the mainshaft third gear. At the same time the second layshaft selector disengages second gear.



1. TIMING SIDE GEARSHIFT FORK
2. QUADRANT
3. CAMPLATE PLUNGER
4. GEAR CONTROL QUADRANT
5. SELECTOR FORK
6. SELECTOR SPINDLE

Fig. D2. Gear selection components

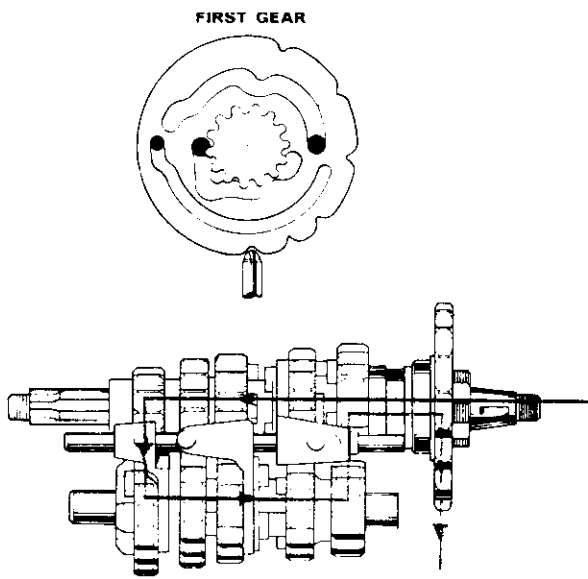
D**TRANSMISSION (GEARBOX)**

Fig. D3(i)
First gear selected (Note arrowed line showing power being transmitted through the gear cluster)

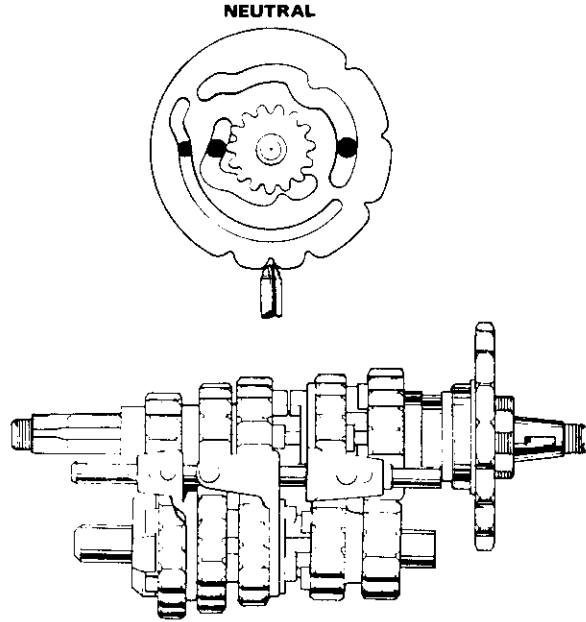


Fig. D3(ii)

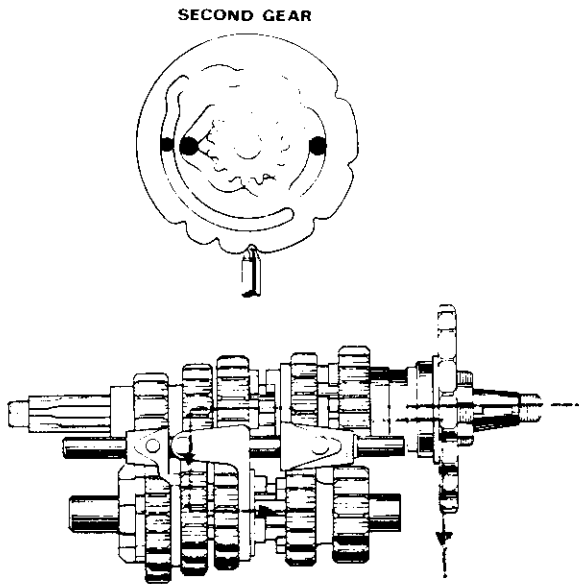


Fig. D3(iii).

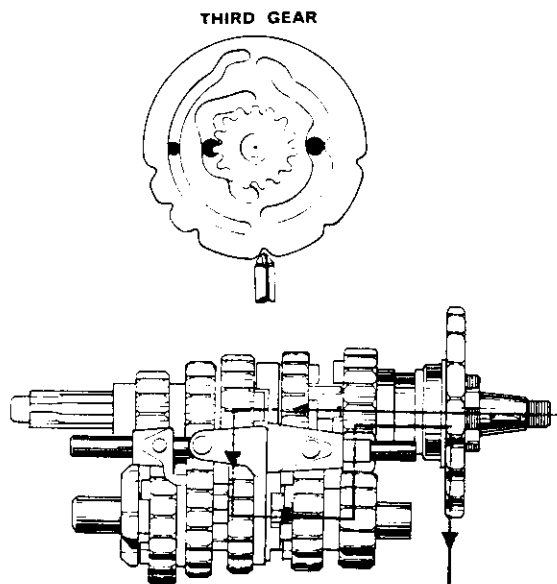


Fig. D3(iv)

Further movement of the gear lever will select fourth gear, by moving the sliding layshaft third gear into mesh with the mainshaft fifth gear, while the mainshaft fourth gear is moved into a neutral position.

Finally, fifth gear is obtained by a final movement of the lever in the same direction. The mainshaft

selector fork will bring the mainshaft sliding gear (fourth gear) into mesh with the mainshaft fifth gear. At the same time the second layshaft sliding gear (third gear) is moved into a neutral position.

It should be noted that throughout the range of gear pedal movements the gear pedal returns to the original position, ready for the next selection.

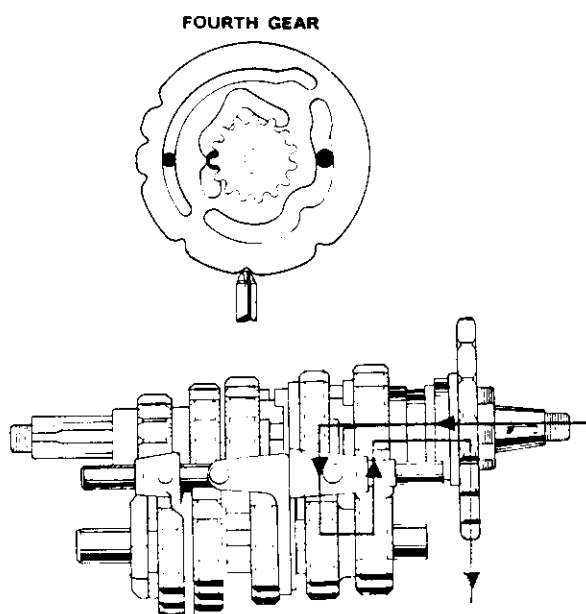


Fig. D3(v)

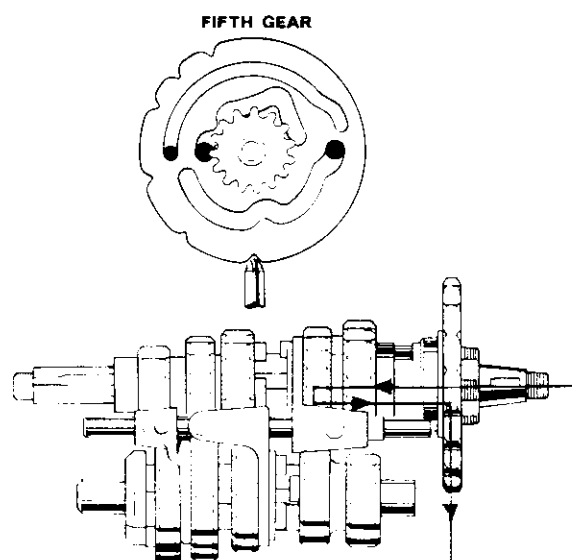


Fig. D3(vi)

SECTION D2

REMOVING AND REPLACING THE TRANSMISSION OUTER COVER ASSEMBLY

Remove the right side footrest. Place a drip tray underneath the transmission (gearbox), and unscrew the filler plug and drain plug ('S' and 'T' Fig. D4).

Engage top gear. This will allow several otherwise difficult nuts to be unscrewed more easily, by subsequently applying the rear brake when required.

Unscrew the three screws (two long and one short) which secure the round inspection cover. Take off the cover. Remove the self-locking nut on the end of the cross shaft, and take off the washer.

Take out the screws around the periphery of the outer cover, and also the retaining nuts. Depress the kickstart lever, until the first tooth of the quadrant engages. Strike the lever downwards with the palm of the hand. This should free the cover.

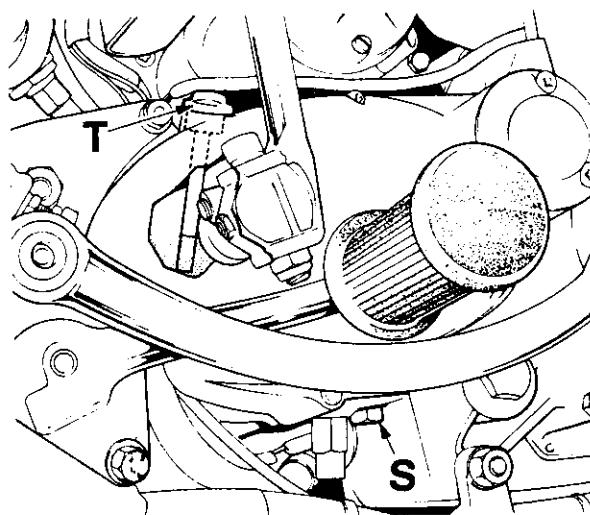


Fig. D4
Draining the transmission

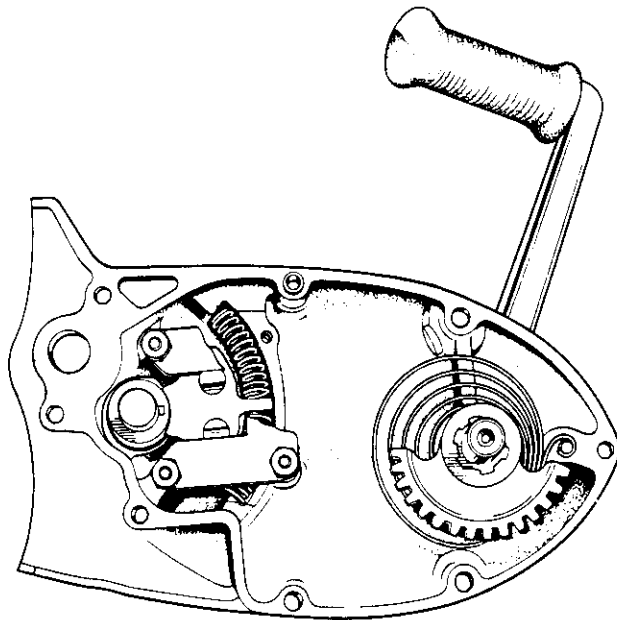


Fig. D5. Transmission outer cover, showing kickstart quadrant and gearchange mechanism

When the cover is removed, the gearchange mechanism and kickstart mechanism will be accessible.

Prior to refitting the outer cover, ensure that the assembly is clean. If necessary, thoroughly cleanse it in kerosene (paraffin). Ensure that the location dowels are in position, and that the gasket is in good order. A new gasket should be fitted if any doubt exists.

Turn the kickstart pedal until it is half way down its operational stroke, and offer the cover to the

gearbox, positioning the cross shaft link ready for it to engage in the splines on the end of the cross shaft.

When the cover is fully home, check that the kickstart pedal returns to its normal fully returned position. Re-assembly then continues as a reversal of the foregoing instructions.

Finally, refill the transmission (gearbox) to the correct level with the recommended grade of oil (See Section A2).

SECTION D3

DISMANTLING AND REASSEMBLING THE KICKSTART MECHANISM

Slacken the kickstarter crank cotter pin nut about two or three turns and release the cotter pin from its locking taper by using a hammer and a soft metal drift. Remove the cotter. Slide the pedal off the shaft and withdraw the quadrant and spring assembly.

Engage a gear, and apply the rear brake. Bend back the tab on the lock washer, and unscrew the kickstart ratchet pinion securing nut from the mainshaft. Withdraw the pinion, ratchet, spring

and sleeve, then thoroughly clean all parts in kerosene (paraffin) and inspect them for wear etc., as shown in Section D5.

If the kickstarter quadrant is to be renewed, the spindle should be driven out using a hammer, or preferably an arbor press, and the gear quadrant pressed onto the spindle, so that the kickstart crank location flat is positioned correctly relative to the quadrant (see Fig. D5).

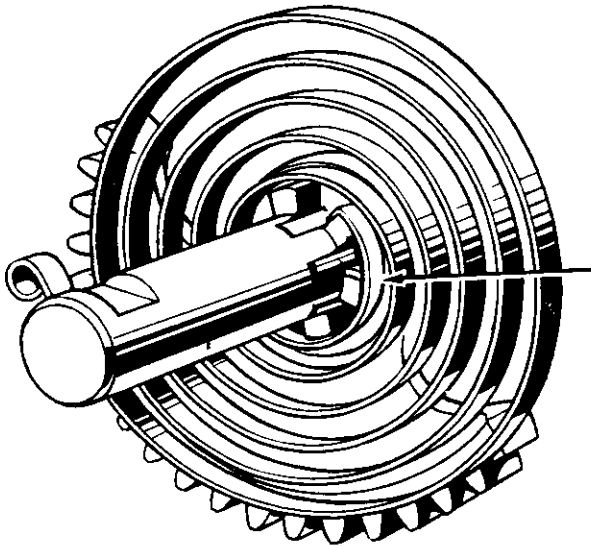


Fig. D6. Kickstart quadrant and spring. Arrow indicates correct spring location.

To reassemble the mechanism, first refit the sleeve, spring, pinion and ratchet to the transmission mainshaft, and reassemble the tab washer. Then screw on the retaining nut to the torque figure given in "General Data". **Do not over-tighten the retaining nut as this may result in failure of the inner steel sleeve.**

Fit the return spring to the kickstart quadrant as shown in Fig. D6. Assemble the spindle into the kick start bush, and locate the return spring onto the anchor peg at the rear of the cover. Fit the oil seal over the spindle, and assemble the kickstart crank, locking it into position with the cotter pin from the rear. Refit the outer cover as shown in Section D2. Do not forget to refit the oil seal. Refill the gearbox with the correct grade of lubricant (Section A2).

SECTION D4

DISMANTLING AND REASSEMBLING THE GEARSHIFT MECHANISM

Remove the four nuts and locking washers securing the guide plate. Withdraw the plate, curved return springs, and plungers and springs. Thoroughly clean the parts in kerosene (paraffin) and inspect them for wear etc., as shown in Section D6.

Use a smear of oil to assist re-assembly. When refitting the retainer plate, remember that a locking washer fits under each of the four nuts.

Refit the springs and plungers, taking care that they are not suddenly ejected from their seats during assembly.

It is unlikely that the gearshift fork will need to be removed, but if, for any reason, it does, it should be remembered that it is keyed in the quadrant. It will therefore be necessary to use a drift or an arbor press to part these items, and a similar procedure will be required to reassemble them.

SECTION D5

DISMANTLING AND REASSEMBLING THE GEARSHIFT CROSS SHAFT

Remove the Left side footrest, and also the primary drive outer cover, after draining the oil from the primary drive assembly. Remove the nut and washer from the end of the cross over shaft. Note the position in which the cross shaft quadrant is fitted, and remove the quadrant from the shaft.

Take off the transmission outer cover on the right side of the machine, as described in Section D2. The cross-over shaft can then be withdrawn from the right side. Note that the splined end of the shaft is to the right side of the machine.

Reassembly is mainly a reversal of the dismantling

procedure. The cross-shaft quadrant on the drive side should be fitted in the position from which it was removed (See Fig. D7).

Next, refit the transmission outer cover, taking care to position the cross shaft link lever ready for fitting onto the splines of the cross shaft as the cover is tapped home. The refitting procedure is detailed in Section D2.

On the primary drive side, check that the gasket is in good condition. If any doubt exists, it should be replaced. Use a smear of grease when locating it on the joint face.

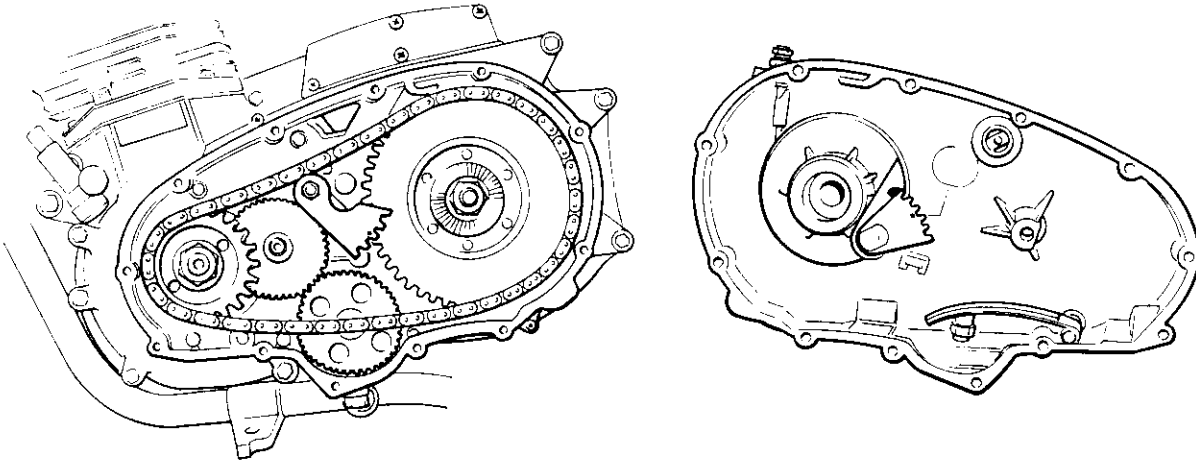


Fig. D7

Take care when offering up the primary outer cover, as it is important to locate the chain tensioner correctly on the bottom run of the chain without moving the gasket. The foot operated gearshift lever should also be in a horizontal position, to enable the quadrant on the gearshift pedal spindle to locate correctly with the quadrant on the cross over shaft (See Fig. D7).

Before finally pushing home the cover, check to ensure that the gasket is still in position and is undamaged. Push home the cover, replacing the securing screws. Check that all the gears engage,

by moving the rear wheel. If all is correct, fully tighten the cover screws.

Connect up the clutch operating cable, and check the clutch adjustment, (See Section C3).

Check the gasket of the clutch adjustment inspection cover, and replace the cover. Replace the left side footrest.

Finally, refill the primary drive case with the appropriate amount and grade of lubricant (Section A2).

SECTION D6

INSPECTING THE GEARSHIFT AND KICKSTART MECHANISM

GEARSHIFT

- (1) Inspect the gearshift plungers for wear, and ensure that they are a clearance fit in the quadrant. Check the plunger springs by comparing their lengths with the figures given in "General Data".
- (2) Examine the plunger guide plate for wear and grooving on the taper guide surfaces. Renew the plate if grooving has occurred.
- (3) Inspect the pedal return springs for fatigue, and if they show signs of corrosion, due to condensation, they should be renewed.

- (4) Examine the quadrant bush for wear and possible ovality by inserting the quadrant into the bush and feeling the amount of play.

- (5) Check the tips of the plungers and the teeth of the camplate operating quadrant for chipping and wear. To remove the camplate quadrant, first remove the inner cover as shown in Section D8, then remove the two split pins and withdraw the spindle.

KICKSTART:

- (1) Examine the kickstart quadrant for chipped or broken teeth, or looseness on the spindle, and

- the kickstart return spring for fatigue cracks and signs of wear, particularly at the centre where it engages on the splines of the spindle.
- (2) Examine the kickstart spindle bush for wear. If the required measuring instruments are not available, use the spindle as a gauge and feel the amount of play.
 - (3) Examine the kickstart ratchet mechanism for

- wear, paying particular attention to the ratchet teeth, ensuring that they have not become chipped or rounded. Check that the thin steel bush is a clearance fit in the kickstart pinion, and that the spring is not badly worn.
- (4) Finally, check that the kickstart stop peg is firmly pressed into the inner cover, and is not distorted.

SECTION D7

RENEWING KICKSTART AND GEARSHIFT SPINDLE BUSHES

If it is found necessary to renew the kickstart spindle bush, this should be done by completely stripping the outer cover of its assembly parts and heating it to 100°C. (boiling water temperature), then driving the bush out using a suitable shouldered drift. Press in the new bush while the cover is still hot.

Adopt a similar procedure for removal of the outer cover gearshift spindle bush. The inner cover bush does not usually wear much, even after great mileage has been covered. However, if it is required to renew the bush, the inner cover should be

removed (Section D8), and the camplate operating quadrant disconnected.

Using a suitable tap (e.g. $\frac{3}{4}$ in. dia. \times 10 Whit.), cut a thread in the bush to a depth of $\frac{3}{4}$ in.; heat the cover to 100°C., then reinsert the tap, or, preferably, a suitable bolt. Grip the bolt (or tap) firmly in a vice, then drive the cover away, using a hide mallet, until the bush is free.

A press or suitably shouldered drift is required to drive in the new bush, which should be done whilst the cover is still hot.

SECTION D8

DISMANTLING THE TRANSMISSION (GEARBOX)

Remove the outer cover as shown in Section D2, leaving the transmission with 5th (top) gear selected.

Remove the rear right engine mounting plate, together with the rear brake pedal (See Section B1 page B5).

Straighten the tags on the lock washer, and unscrew the kickstart pinion ratchet retainer nut from the end of the mainshaft. This should be easily achieved with 5th (top) gear selected and the rear brake applied.

Remove the outer primary cover, and dismantle the drive, shown in Section C, not forgetting, finally, to remove the key from the transmission mainshaft.

The gearbox inner cover is retained by a socket screw, two cross head screws, and a bolt (See Fig. D8). When these are removed, the cover can be released by tapping it outwards with a hide mallet.

Withdraw the engaging dog from the layshaft (See Fig. D9). Then remove the circlip from the end of the layshaft with a pair of circlip pliers. Pull the selector rod out and then remove the layshaft first gear with its selector fork. Withdraw the second gear from the layshaft and then remove the mainshaft complete with first, second, and third gears in position. Remove the mainshaft fourth and layshaft third gears with their selector forks, and then withdraw the layshaft with the fifth and fourth gears in position. Detach the two brass thrust washers which locate over the needle roller bearings. Before removal of the camplate, the mainshaft high gear will have to be detached from the gearbox sprocket, and withdrawn from the crankcase. This can be done by removing the circular plate from the primary inner cover at the rear of the clutch, tapping back the bent-over portion of the locking plate, and unscrewing the large hexagonal gearbox sprocket nut (1.875" across the flats). To facilitate removal of the nut, Workshop Tool number 60-6125

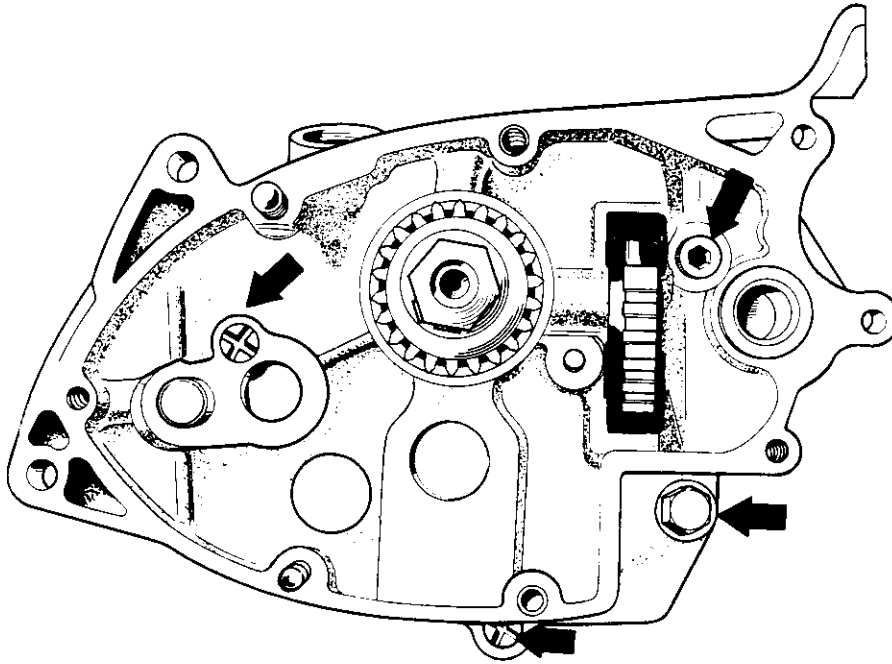


Fig. D8. Transmission inner cover retaining screws

is available. When the nut has been removed, tap the high gear into the gearbox, using a hide mallet or a soft metal drift. It is now possible to remove the camplate from its housing in the crankcase. To remove the gearbox sprocket, disconnect the rear chain and remove it from around the sprocket which

can now be easily withdrawn through the aperture. The oil is prevented from leaving the gearbox through the main bearing by an oil seal which runs on a ground boss on the gearbox sprocket. Check the oil seal for cracking and wear (see Section D9 for bearing and oil seal removal details).

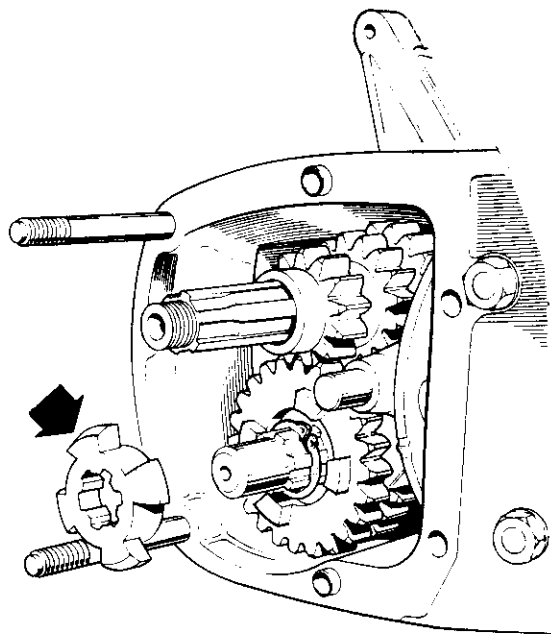


Fig. D9. Showing removal of engaging dog

SECTION D9

INSPECTION OF THE TRANSMISSION (GEARBOX) COMPONENTS

Thoroughly clean all parts in kerosene (paraffin) and check them for wear and fatigue, as follows:—

- (1) Inspect the housing and inner cover for signs of cracking and damage to the joint faces. Check that the location dowels are in their correct positions in the gearbox and inner cover (2 dowels each). In preparation for re-assembly, clean all the joint faces.
- (2) Examine both the mainshaft and layshaft for signs of fatigue, damaged threads, and badly worn splines. Check the extent of wear to the bearing diameters of both shafts by comparing them with the figures given in "General Data". Examine the shafts carefully for signs of seizure. Excessive frictional resistance and seizure will be indicated by local coloring on the shaft.
- (3) Check the layshaft needle roller bearing by inserting the layshaft and feeling the amount of play.
- (4) Inspect the mainshaft bearings for roughness due to pitting or indentation of the ball/roller tracks. Note that the high gear bearing operates directly in a roller bearing pressed into the left side crankcase half. If wear is apparent at the high gear bearings (check general data for high gear spigot dimensions), it will be necessary to replace the roller bearing *and* the high gear. **Under no circumstances should the bearing or the high gear be replaced independently.** Check the inner cover bearing by feeling the amount of side play of the centre track. It should not be possible to detect any movement by hand if the bearing is in good condition. The mainshaft should be a push fit in the inner cover bearing.
- (5) Examine the gears thoroughly, for chipped, fractured or worn teeth. Check the internal splines, dogs and bushes. Make sure that the splines are free on their respective shafts without any tendency to bind, and that the bushes in the mainshaft third gear, layshaft second gear, and layshaft first gear, are not loose, or excessively worn. Again, reference should be made to the dimensions given in "General Data".
- (6) Check that the selector fork rod is not grooved, and that it is a good fit in the casing and the inner cover. Inspect the selector fork running faces for wear. This will have occurred only if the gearbox is being continually used with a badly worn mainshaft bearing.
- (7) The gear selector camplate should be inspected for signs of wear in the selector tracks. Excessive wear will occur if the mainshaft bearing has worn badly. Check the fit of the camplate spindle in its housing. Examine the camplate gear wheel for excessive wear. Difficulty will be encountered in gear selection if this gear is badly worn, causing subsequent damage to the gears.
- (8) Inspect the mainshaft high gear needle roller bearings for roughness or fracture. Check the mainshaft diameter with the "General Data", and check for surface pitting or damage due to scoring.

SECTION D10

RENEWING MAINSHAFT AND LAYSHAFT BEARINGS

MAINSHAFT

The bearings are a press fit in their respective housings and that on the right side is retained by a spring circlip to prevent sideways movement due to end thrust. To remove this bearing, first lever out the circlip, then heat the cover to approximately 100°C. (boiling water), and drive out the bearing, using a suitably shouldered drift. The new bearing

should be pressed or drifted in whilst the cover is still hot, using a suitable tubular drift onto the outer race. Do not forget to refit the circlip.

To remove the high gear bearing on the left of the machine, first remove the screws and oil seal holder. Carefully heat the casing locally to approximately 100°C., then drive out the bearing from the inside of

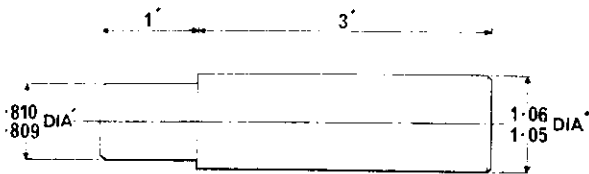


Fig. D10. Drift dimensions.

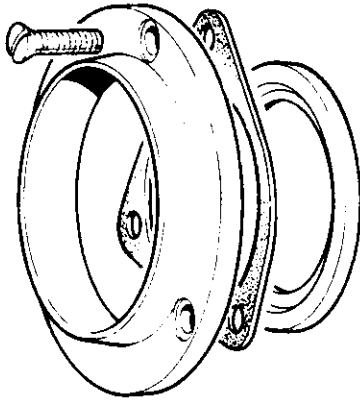


Fig. D11. High gear bearing oil seal and housing

the casing, by means of a suitably shouldered drift. Whilst the casing is still hot, drive in the new bearing, using a suitable tubular drift on to the outer race, and press in the new oil seal into the holder.

Note: The drift will, of necessity, be located against the roller end faces, and thus it is not advisable to disturb this bearing unless it is to be replaced by a new one (See Section D8 para.4).

MAINSHAFT HIGH GEAR BEARINGS

Two caged needle bearings are fitted into each end of the high gear and they can be both pressed out together using a drift to the dimensions given in Fig. D9.

LAYSHAFT

The right needle roller bearings should be removed by heating the cover to approximately 100°C., then pressing or drifting out the bearing using a tool similar to that shown in Fig. D 12. Put aside the thrust washer and note its location.

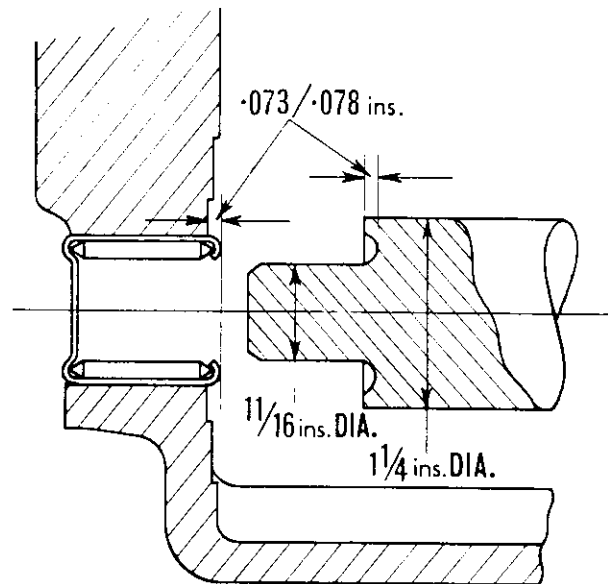


Fig. D12. Sketch of needle roller and drift

The new bearing should be pressed in whilst the cover is still hot, from the inside of the cover, until .073/.078 in. of the bearing protrudes above the cover face (see Fig. D 12).

The left needle roller bearing is of the closed-end type and is accessible from the left, through the sprocket cover plate aperture. The casing should be heated to approximately 100°C. and the bearing driven through into the casing using a soft metal drift, taking care not to damage the bore into which the bearings fits. Put aside the thrust washer, and note its location.

The new bearing must be carefully pressed in the casing is hot, until .073/.078 in. protrudes above the machined face inside the case. Do not use excessive force or the needle roller outer case may become damaged, resulting in the rollers seizing, or breaking up.

Finally, the outer portion of the bore into which the bearings fits, should be sealed with a suitable proprietary sealant.

SECTION DII

REASSEMBLING THE TRANSMISSION (GEARBOX)

Lubricate the camplate and spindle and offer it into the spindle housing within the case.

Fit the high gear bearing oil seal in its circular housing, the closed side flush with the outer face. (See

Fig. D11). Assemble the high gear in the bearing. Lubricate the ground boss, of the sprocket with oil, and slide it through the seal and onto the high gear. Screw on the securing nut, finger tight.

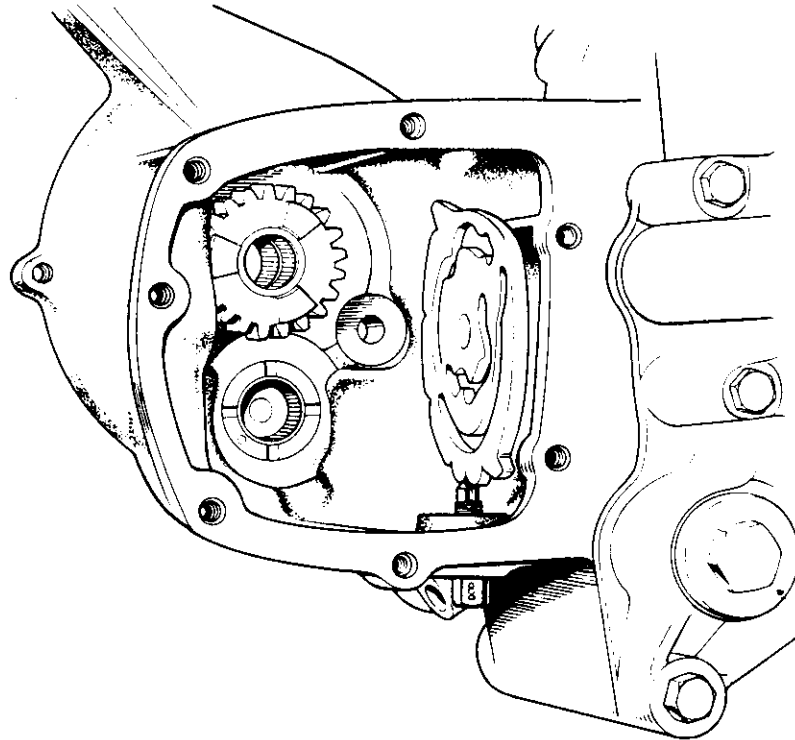


Fig. D13. Reassembling the transmission (gearbox). Illustration indicates camplate in the neutral gear position

Re-mesh the rear chain with the sprockets and replace the connecting link. Apply the rear brake and tighten the sprocket securing nut as tight as possible, using service tool 61-6061.

Locate the thrust washer over the inner needle roller bearing. The washer can be held in position by smearing its rear surface with grease. Note that the grooved surface is towards the layshaft. (See Fig. D 13).

Set the camplate in the neutral gear position (See Fig. D 13). Lubricate the needle roller bearings in the high gear (use oil recommended in Section A2) and layshaft bearing. Place the mainshaft fourth gear with its respective selector fork onto the mainshaft. See Fig. D 1. This selector fork has a large engaging pin and no cuttaway on the housing. Assemble the shaft into the high gear using a heavy grease to retain the selector fork on the gear and in the camplate track. Replace the layshaft assembly with fifth and fourth gears into the gearbox and engage with the mainshaft fifth and fourth gears (note that with the gearbox in the neutral position none of the sliding dogs will be engaged).

Replace the layshaft third gear with its respective selector fork (See Fig. D 1). This selector fork has a large engaging pin and a cuttaway on the selector housing. Then replace the mainshaft third gear and engage with the layshaft third. Replace the layshaft second gear after first lubricating the bush with oil. Replace the combined first and second gear onto the mainshaft. Replace the layshaft bottom gear with its selector fork (this selector fork has a small diameter engaging pin and a cuttaway to match the previous selector fork. See Fig. D 1. Replace the selector rod. Fit the circlip onto the end of the layshaft and the engaging dog up against the circlip. Turn the camplate towards the inner cover from the top, thereby placing the gearbox into the first gear position (note engaging dog on layshaft will be in mesh with the dogs on the layshaft first gear).

Check the camplate operating quadrant is moving freely in the inner cover and position the bronze layshaft washer over the needle roller bearing in the inner cover. Again, use grease to hold the thrust washer in position during assembly.

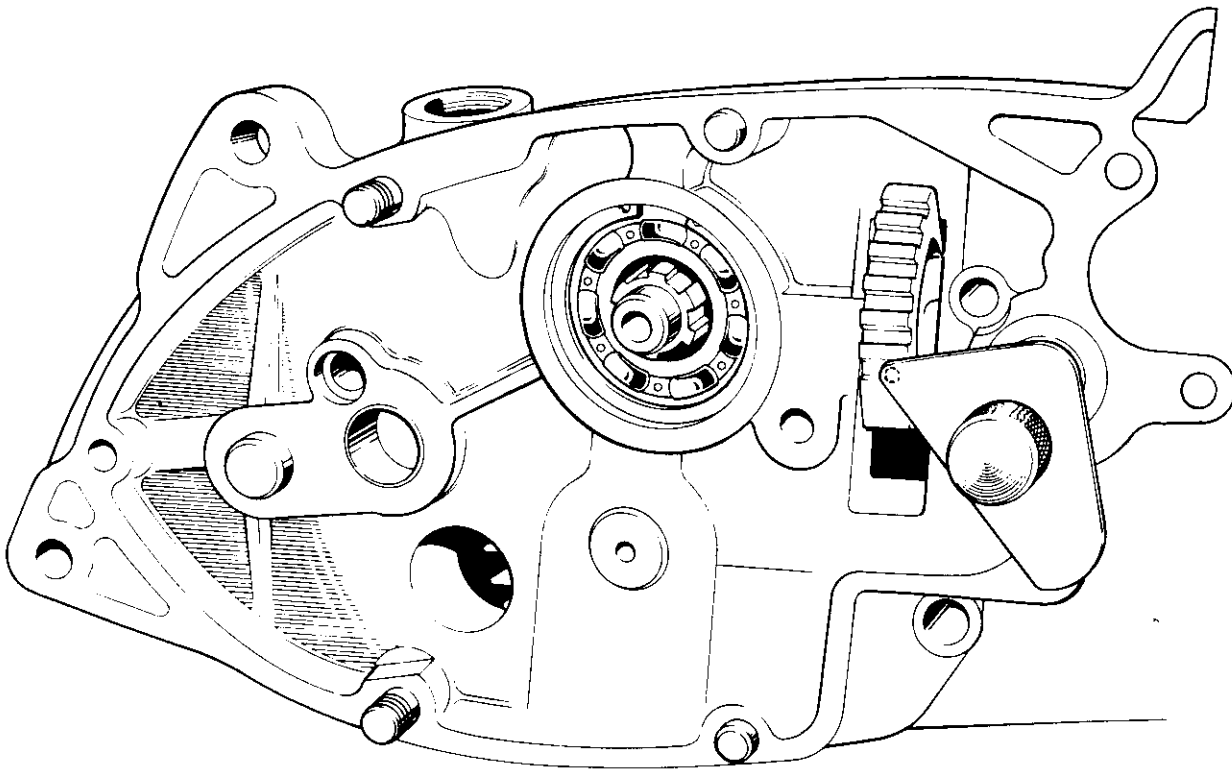


Fig. D14. Refitting the gearbox inner cover

Using a pressure oil can, lubricate all the moving parts in the gearbox. Check the condition of the gasket which fits between the crankcase and the inner cover. Place it in position with a smear of grease.

Ensure that the two location dowels are in position and offer the inner cover assembly to the gearbox. When the cover is approximately $\frac{1}{4}$ in. (6 mm.) away from the gearbox junction face, position the camplate quadrant as detailed in Fig. D 14 and position service tool 61-7011 as shown. If this tool is not available, line up the top edge of the second tooth on the quadrant with the centre line passing through the footchange spindle housing.

Screw in the socket screw, recessed screws and the bolt, then temporarily assemble the outer cover and gearchange lever and check that the gearchanging sequence is correct by simultaneously operating the

gearchange pedal and turning the rear wheel. In the event of any problem of selection it must be assumed that the quadrant teeth are not engaged accurately with the camplate pinion. To rectify this, remove the inner cover again and check that the camplate has been set in the first gear position. Offer up the inner cover and repeat as previous.

When correct gearchanging is established, reassemble the kickstart pinion and ratchet, replace the tab washer and screw on the securing nut to the torque figure given in "General Data". To facilitate this, the rear brake should be applied with top gear selected.

Refit the gearbox outer cover as shown in Section D 2 then reassemble the transmission, referring to section A2 for the correct quantities and grades of lubricant for the primary chaincase and gearbox.

SECTION D12

CHANGING THE TRANSMISSION (GEARBOX) SPROCKET

Remove the left side footrest. Place a suitable container beneath the centre of the chaincase, and remove the drain plug. Allow a few minutes for the case to drain, and then remove the outer chaincase (Section C5), the primary drive (Section C7), the inner chaincase, the clutch, and the clutch cover (Section C6).

Tap the tab washer clear of the transmission sprocket retaining nut. Leave the chain in place and uncrew the transmission sprocket securing nut, using Service tool 61-6061. The rear chain may now be disconnected, and the transmission sprocket withdrawn. The sprocket will need to be removed using the extractor 61-6046.

Before fitting the new sprocket, check that the transmission case oil seal is in good condition, and that the rear chain is not excessively worn. Check the stretch, as shown in Section A14.

If the old chain is to be retained for further use, it should be thoroughly cleaned in kerosene (paraffin) and lubricated in a grease bath. Lubricate the pinion boss with oil, fit a new locking plate gasket, and slide the sprocket over the transmission mainshaft and high gear. When the sprocket is located on the splines, screw on the securing nut finger tight, then re-connect the chain.

With the rear brake applied, tighten the nut as tight as possible, and tap over the lockplate.

SECTION E

FRAME AND ATTACHMENT DETAILS

	<i>Section</i>
REMOVING AND REFITTING THE FUEL TANK	E1
REMOVING AND REPLACING THE STYLING COVERS	E2
REMOVING AND REPLACING THE OIL TANK	E3
REMOVING AND REPLACING THE BATTERY CARRIER ASSEMBLY	E4
REMOVING AND REPLACING THE REAR FENDER, LIFTING HANDLE, ETC.	E5
ADJUSTING THE REAR SUSPENSION	E6
REMOVING AND REFITTING THE REAR SUSPENSION UNITS	E7
DISMANTLING AND REASSEMBLING THE SUSPENSION UNITS	E8
REMOVING AND REFITTING THE SWINGING FORK	E9
RENEWING THE SWINGING FORK BUSHES	E10
REMOVING AND REPLACING THE REAR FRAME	E11
FRAME ALIGNMENT	E12
FAIRING ATTACHMENT LUGS AND STEERING LOCK	E13
FITTING REPLACEMENT SEAT COVERS	E14
REPAIRS	E15
PAINTWORK REFINISHING	E16

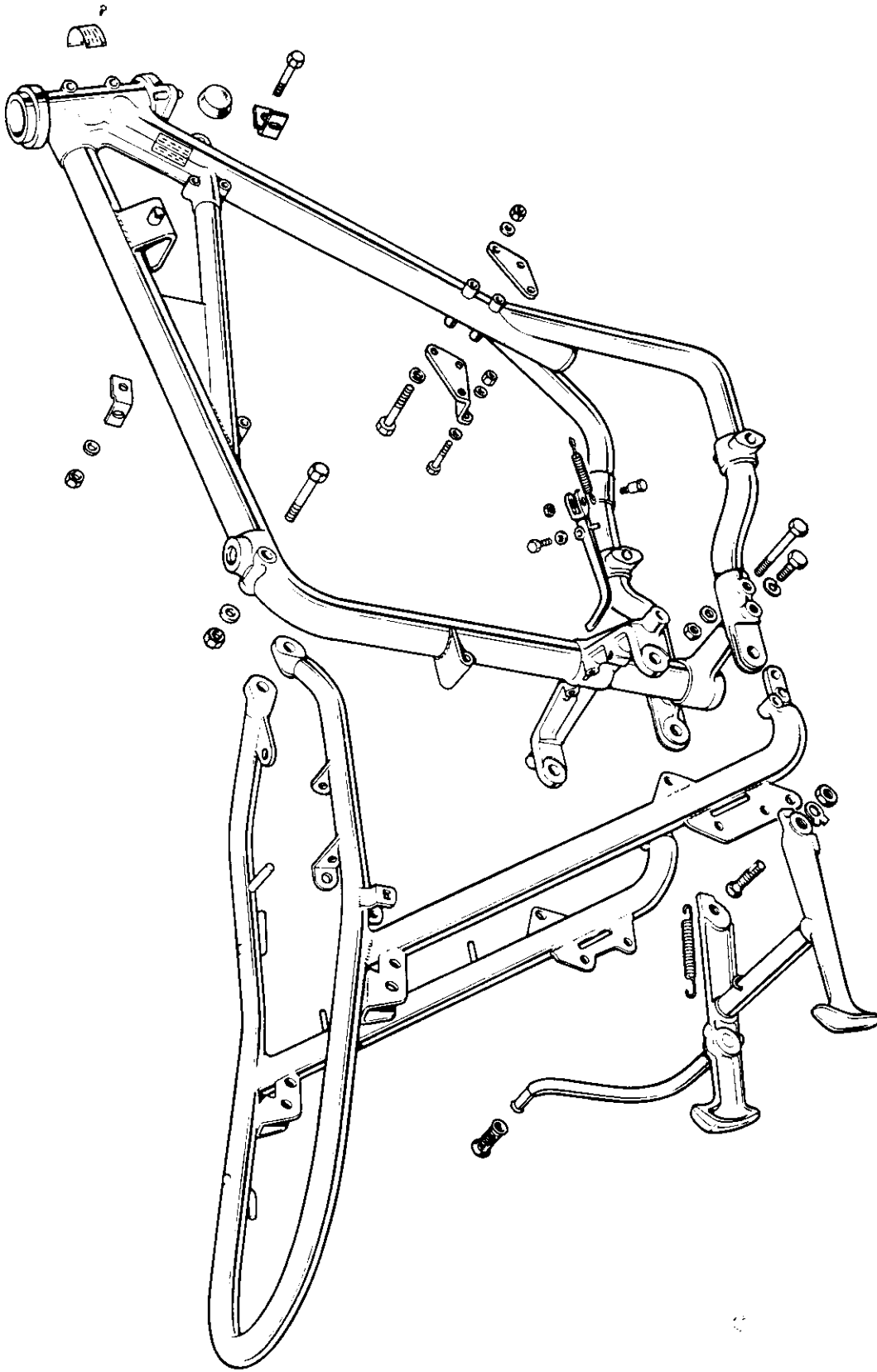


Fig. E1. General arrangement of front and rear frame assembly

SECTION E1

REMOVING AND REPLACING THE FUEL TANK

Turn both fuel taps to the "off" position, then unscrew both unions and disconnect the feed pipes at the taps. Open the twin seat, then unscrew the rear securing screw complete with mounting rubbers, cups, etc. Carefully note the order of assembly.

Raise the rear end of the tank and then lift the whole tank upwards to draw it off the rubber buffers attached to the frame top tube, and which locate in pockets in the tank center tunnel. Take great care not to damage the tank enamel.

When re-mounting the tank, these buffers must be retained, because they prevent metal-to-metal contact between tank and frame. Fit the front end first, and lower the rear end into position. Re-assemble the flexible mounting in the sequence shown in Fig. E2 and note that one rubber pad is plain, while the other is spigotted.

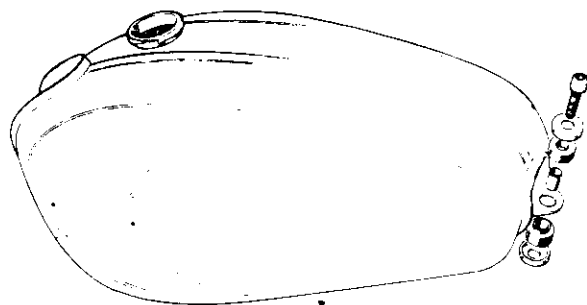


Fig. E2. Assembly order of fuel tank mountings

SECTION E2

REMOVING AND REPLACING THE STYLING COVERS

To remove the right side styling cover remove the two cross-head screws which secure the cover to the oil tank, and withdraw the cover.

To remove the left side styling cover, open the twinseat and unscrew the plastic securing knob at

the top front of the panel. Slide it forwards off the two mounting pegs at the rear to remove from the frame.

Refitting the panels is a direct reversal of the above.

SECTION E3

REMOVING AND REPLACING THE OIL TANK

Open the twin seat and disconnect the breather pipe from its branch just in front of the filler. Unfasten the securing clip and disconnect the pipe running from the top front of the oil tank (this leads to the right side of the oil cooler). Remove the right side styling cover, after taking out the two cross-head screws. With a drain tray beneath the machine, disconnect the feed pipe union nut at the bottom front of the tank and allow several minutes whilst the tank completely drains. Remove the gauze filter (large hexagon head).

Unfasten the front top mounting nut, releasing the seat retaining wire, and push the slot headed peg clear of the spigotted rubber.

Then unfasten the rear top mounting nut and washer in a similar manner.

Lift the tank off the bottom rubber-sleeved spigot and move the top inwards. The bottom can then be pulled outwards and down until the tank is clear of the frame.

To remount the tank, fit the top first, upwards and behind the top rear frame rail. The tank can then be positioned over the bottom mounting spigot. Do not omit the rubber sleeve.

E

FRAME

Refit the slot headed pegs through the spigotted rubbers (see Fig. E3), and add the nuts and washers, not forgetting to replace the twin seat check wire on the front peg. Clean the gauze filter in Kerosene (paraffin), and replace the fibre washer if the old one appears in any way damaged. Refit the filter. Re-connect the breather, top return and bottom feed pipes to the tank.

Refill the tank with the correct quantity and grade of oil (refer to Sections A1 and A2).

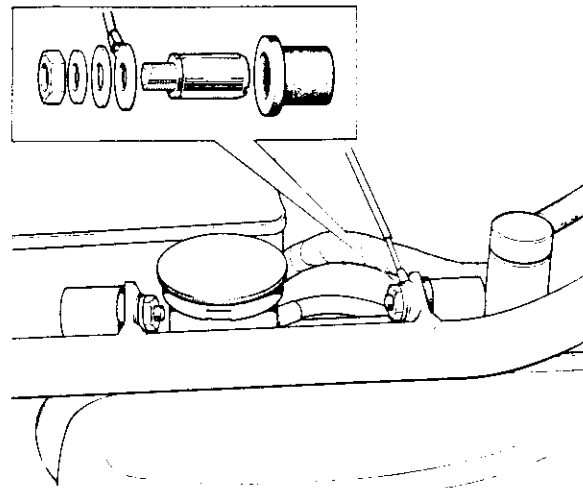


Fig. E3. Oil tank rubber mountings

SECTION E4

REMOVING AND REPLACING THE BATTERY CARRIER

Remove both styling cover, as in section E2. Disconnect and remove the two coils located on the battery carrier. The third (on the oil tank) need not be disturbed. The coils are a sliding fit in their rubber grommets. Make a note of the positions and colors of the various leads, to ensure accurate replacement.

Disconnect the brown/blue lead to the battery together with the starter cable and then the red (positive) cable. Unhook the rubber retaining strap at the front of the carrier and take the battery out from the left side. Remove the rubber tray. Remove the screws securing the electrical equipment to the base of the carrier (starter relay, ballast resistor, etc.) and carefully put aside.

Remove the long bolt coupling the carrier platform to the frame seat tube, leaving the two rubber bushes in the frame lug.

There now remains the upper carrier connection. Prise out the spring ring retaining the rubber bush in the fixing loop (left side) and slide the carrier off the frame peg, when the carrier can be withdrawn from the side of the machine. Examine all the

rubber bushes, renewing any which may be damaged. The hook on the retaining strap is adjustable for position and must be set so as to restrain the battery firmly.

Reassembly is a reversal of the fore-going, reference being made to Fig. E4 for the correct order of assembly of grommets etc.

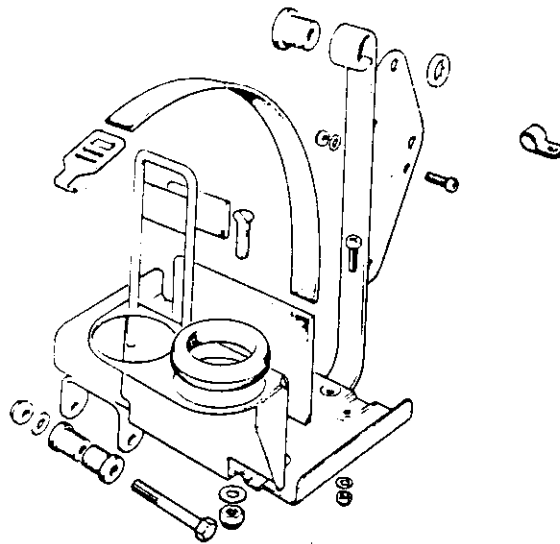


Fig. E4. Battery carrier mountings

SECTION E5

REMOVING AND REFITTING THE REAR FENDER, LIFTING HANDLE, ETC.

Remove the nuts on the upper suspension unit bolts and withdraw these sufficiently to clear the lifting handle. The bolts need not be completely removed. Disconnect the multi-pin connection in the wiring cables to the rear lite. Note that when re-connection is made, the cable colors must correspond i.e. red to red, etc.

clip from the left side of the toolbox. (Access to the latter is given by removal of the left styling cover).

Following removal of the lower fixing bolt (near the swinging arm pivot) the front portion of the fender may be manipulated clear of the frame.

The rear portion of the fender is secured to the front part (plastic) by two nuts and bolts on a bridge member and a further two bolts clip it to the rear frame loop. When all four bolts are removed, this portion of the guard can be lifted out, together with all its fittings, such as tail lite assembly, number plates, indicator lites, and wiring harness.

The fender may now be dismantled on a bench. The tail lite carrier is attached to the fender by a stud with its nut inside the fender, while the number plate and tail lite support plate are secured by four nuts and bolts. Two bolts attach the lifting handle to the fender. The handle can be taken off following removal of the tail lite carrier. Great care must be taken when any of the wiring harness is uncoupled at the snap connectors, to make sure that, on re-assembly, the correct colors are joined together, and it will be advisable to use small adhesive labels on the cables to facilitate this requirement.

If the suspension unit bolts have been completely withdrawn, note that they should be re-assembled with their heads on the outside of the machine. To remove the front section of the rear fender (plastic), the harness clip must be released from the front face of the toolbox portion, and an oil pipe

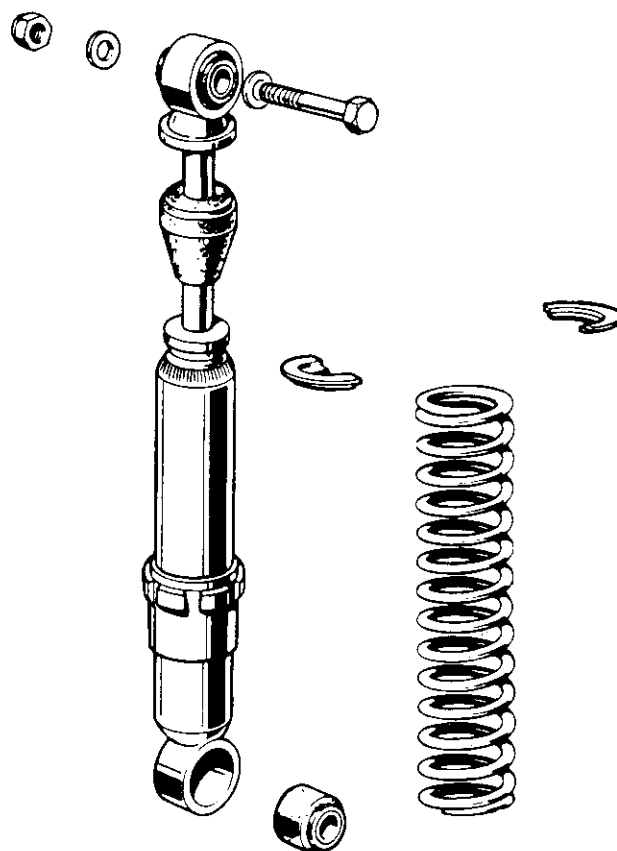


Fig. E5. Exploded view of the rear suspension unit

SECTION E6

ADJUSTING THE REAR SUSPENSION

The movement is controlled by Girling combined coil spring and hydraulic damper units (see Fig. E5). The hydraulic damping mechanism is completely sealed, but the static loading of the spring is adjustable.

There is a concealed three position cam ring, below the spring and a "C" spanner is provided in the toolkit for adjustment (see Fig. E6).

To increase the static loading of the spring, place the machine on its center stand, so that there is least load on the spring and use the "C" spanner to turn the cam; both units must be on the same notch, whichever may be chosen.

The standard (lowest) position is for normal riding, i.e. solo, with the two other positions available for adjustment in accordance with increased loading, such as addition of pillion rider, and/or baggage.

The raised positions should also be used when the motor-cycle is ridden on rough ground.

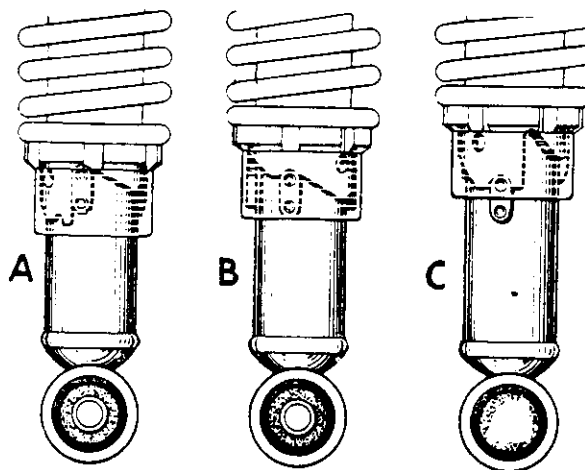


Fig. E6. Adjusting the rear suspension units

SECTION E7

REMOVING AND REFITTING THE REAR SUSPENSION UNITS

Removal of the suspension units is achieved by extracting the top and bottom fixing bolts whilst the machine is mounted on its center stand, so that the rear wheel is off the ground.

The top fixing bolts are fitted with their heads towards the outside of the machine, to facilitate removal of the suspension units without dismantling the hand rail assembly. Their nuts are accessible after opening the twinseat.

Before the bottom bolts can be withdrawn, it will be necessary to remove the mufflers. These are

retained by clips to the exhaust collector box and by bolts to the pillion footpeg plate.

Note carefully if any washers are fitted adjacent to the eye of the suspension unit, and if so, they must be replaced in the same position.

When refitting the suspension unit, ensure that the hand rail is positioned inside the frame brackets. It may be necessary to use an alignment bar to assist in bringing the bolt holes into line.

SECTION E8

DISMANTLING AND REASSEMBLING THE SUSPENSION UNITS

To dismantle the suspension unit and remove the spring, it is required to compress the spring whilst the two semi-circular spring retainer plates are removed. To do this first turn the cam until it is in the "light-load" position, then carefully grip the bottom lug in a vice. Do NOT grip the body.

Use Girling Service Tool as shown in Fig. E7, but if not available, compress the spring sufficiently to allow the two retainers to be extracted. The same tool is used for replacing or renewing the spring.

The damper unit should be checked for leakage, bending of the plunger rod, and damping action. Check the bonded pivot bushes for wear, and ensure that the sleeve is not loose in the rubber bush. The position of any washers should be noted.

The bushes can be renewed easily by driving out the old one and pressing in the new one using a smear of soapy water to assist assembly.

When reassembling check that the cam is in the light load position before compressing the spring.

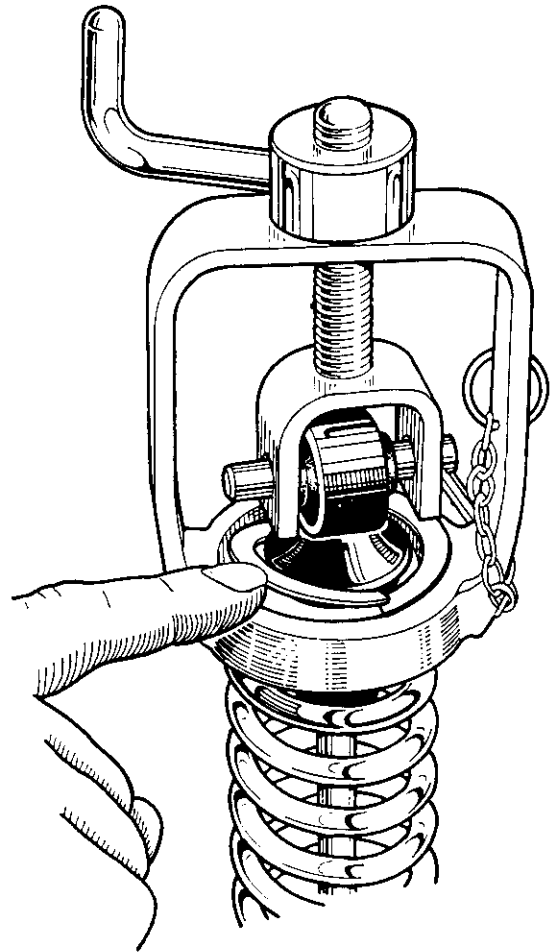


Fig. E7. Using Girling tool to dismantle suspension unit

SECTION E9

REMOVING AND REFITTING THE SWINGING FORK

Set the machine on its centre stand so that the rear wheel is clear of the ground. Remove both mufflers, which are attached to the pillion footpeg plates by bolts, and by clips to the exhaust collector box beneath the engine.

Take off the left side styling panel (Section E2) to expose the chainguard front connection, and unscrew the bolt. Remove the bolts securing the lower ends of the shock absorbers to the swinging arm. This will also release the rear fixing point of the chainguard, leaving it free for removal.

Uncouple the rear chain at its spring link, and remove it from the rear sprocket. Do not unwind it from the transmission sprocket, because this will greatly simplify replacement of the chain. Disconnect the speedometer driving cable at its union with the gearbox on the rear wheel, which will then leave the wheel ready for removal (see Section F17). Remove the wheel.

Before the fork spindle becomes accessible, it is necessary to remove the rear engine plates, together with ancillary fittings. Unscrew all the bolts securing the left side yoke plate, noting the position of the washers and distance pieces. When the plate is removed, the footpeg may remain undisturbed. On the right side of the machine, the torque arm which carries the brake caliper is attached to the swinging arm by a short link. Remove the bolt at the upper connection and note the position of the washers. These are situated so that the link is free to re-align itself when the wheel is removed during chain adjustment and the washers must be replaced in their original position. The securing nut is of the self-locking type and it is advisable to fit a new one when re-assembling.

The brake lever at the inner end of the brake fulcrum spindle is attached to the master brake cylinder rod by two sleeve nuts, one at each side of the lever. Remove the front nut shown at A, Fig. E8.

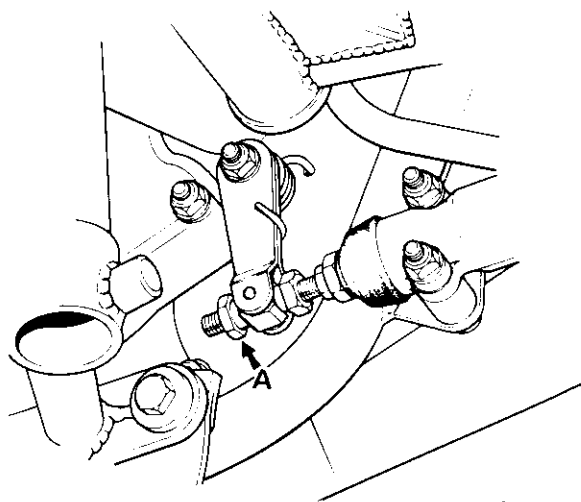


Fig. E8. Rear brake connection at master cylinder

Remove the bolts securing the right side pillion footpeg plate to the frame, but do not disturb the mounting of the master cylinder. Draw the plate rearwards in order to extract the brake rod from the lever and lay on one side. It is not necessary to disconnect any of the hydraulic lines, since two of these are flexible and, with care, give sufficient freedom of movement.

The stop light switch must be disconnected next by withdrawal of the two spade type connectors. Note the cable colors of these connections to ensure correct re-assembly.

Remove the bolts securing the right side engine plate to the frame, when it will be of advantage to take the footrest off first, in order to improve access to some of the bolts. The brake pedal assembly and the stop light switch need not be removed from the plate. The long upper bolt also retains the ground (earth) cable which must not be omitted during re-assembly.

On the left side of the swinging arm spindle, remove the securing nut after straightening the tab washer and unscrew the spindle from the right side. As soon as the threads are disengaged, support the swinging arm and withdraw the spindle. The lipped end plates, 'O' rings, bobbins and distance tube will also be released. (See components in Fig. E9).

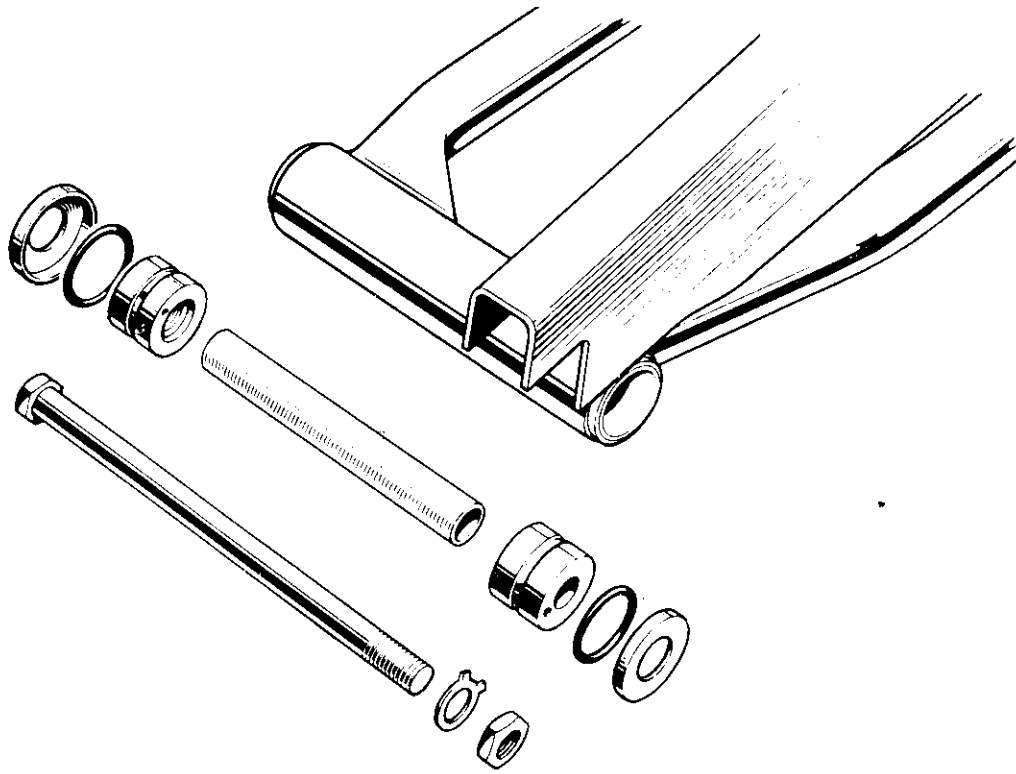


Fig. E9. Exploded view of swinging fork assembly

All parts should be thoroughly cleaned in kerosene (paraffin) and inspected for wear, paying particular attention to the clearance between the bobbins and bushes in the pivots. Check the dimensions with those given on page GD6. If the wear is excessive i.e. more than .008"-.010" the bushes and/or bobbins will have to be renewed. This is described in Section C10. The parts should be assembled as shown in the illustration Fig. E9. During assembly, make sure that the bobbins and bushes are well greased and the space surrounding the distance tube should be greased-packed (see Fig. E12). Recommended grades of grease are given in the table on page A5.

The 'O' rings should be inserted into their housings and fitted over the ends of the fork cross tube.

Position the fork in the frame pivot lug and insert the spindle from the right side. Tighten the spindle in the frame until the fork can just be moved upwards and downwards with little effort. Fit the tab washer and securing nut to the left side of the spindle. Tighten the latter and lock with the washer.

Note.—When the bushes etc., are sound, but sideplay is evident, this can be rectified by taking out the distance tube and reducing its overall length, by either machining or filing. It is essential that the tube ends are kept parallel with each other during such operations.

SECTION E10

RENEWING THE SWINGING FORK BUSHES

If the swinging fork bushes require renewing they should be removed by means of a suitable soft metal drift inserted in the tubular housing at an angle and located on to the far side bush. By dexterous use of a hammer and a drift moving it round the edge of the bush a little at a time the bush should be easily removed without damage to the bore of the housing (see Fig. E10).

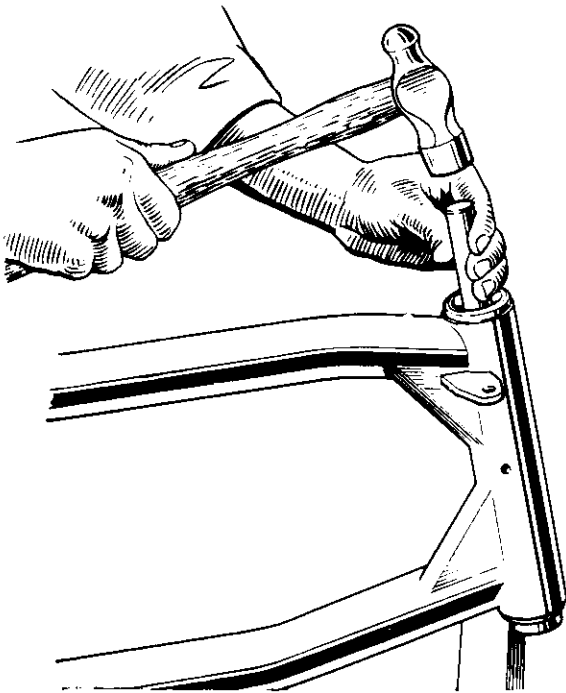


Fig. E10. Removing a swinging fork bush

New bushes are of the steel backed pre-sized type and when carefully pressed in, using a smear of grease to assist assembly, they will give the correct diametral working clearance. If a press is not available the bush can be fitted by using 61-6050 drift and a hammer (see Fig. E11). Ensure that the bush

enters squarely and that no burr is set up due to misalignment. Bore sizes and working clearances are given in "General Data".

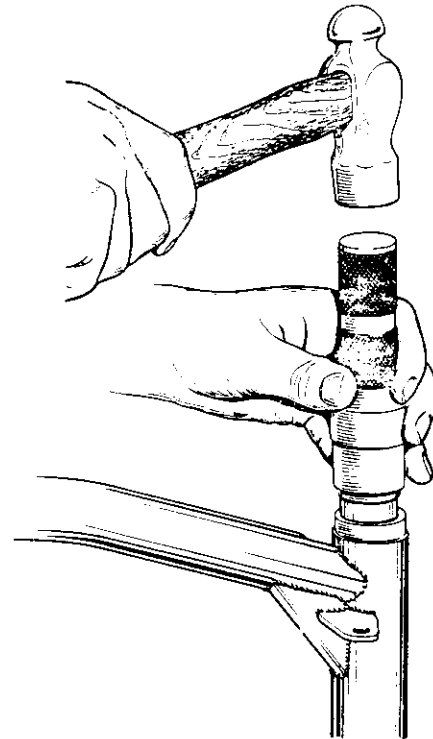


Fig. E11. Refitting bushes with drift 61-6050

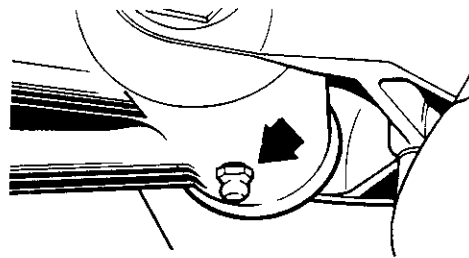


Fig. E12. Swinging fork grease nipple

SECTION E11

REMOVING AND REPLACING THE REAR FRAME

Remove the styling covers (Section E2), disconnect and remove both the battery and the battery carrier (Section E4). Lift the twinseat, disconnect the check wire at the seat pan, and remove two bolts and spring washers holding the front hinge to the twinseat pan. Slide the seat complete with rear hinge plate off the rear frame hinge pin.

Slacken the clamp bolts at both muffler/collector box joints, then remove the two bolts securing each muffler to the pillion footrest mounting brackets. This should free both mufflers for removal.

Disconnect the spade connectors at the various items of electrical equipment, at the same time labelling each connector, so that it can be replaced on its proper terminal, on re-assembly.

Remove the oil tank (Section E3).

Remove the rear wheel (Section F17).

Remove the rear suspension (Section E7).

Remove the rear chainguard and swinging arm (Section E9).

Remove the rear fender (Section E5).

Take off the left and right side rear engine mounting plates, complete with footrests.

Ensuring that the machine is supported securely on the center stand, remove two bolts and two nuts and bolts holding the bottom of the rear frame to the front frame, and lastly, remove the top bolt and nut (located just to the rear of the gas tank), at which point, the rear frame is free to be withdrawn.

If the spade type connectors were not properly marked when dismantling, refer to the wiring diagram (Section H19) when re-connecting the electrical units.

SECTION E12

FRAME ALIGNMENT

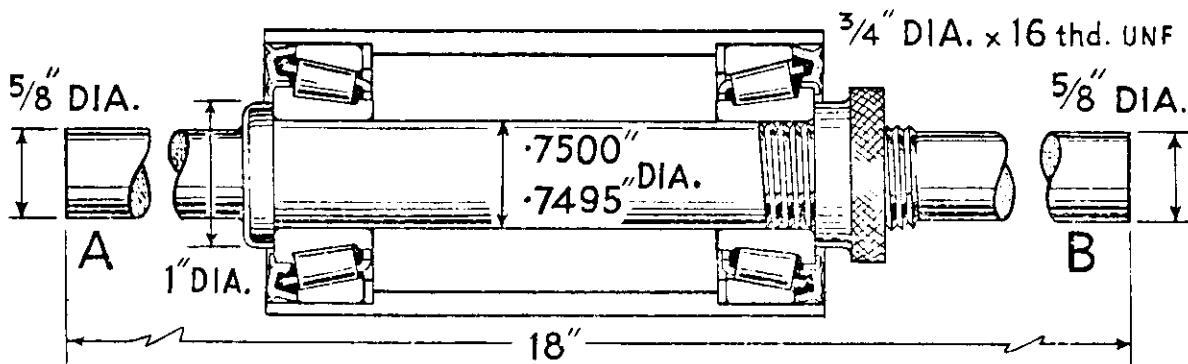


Fig. E13. Steering Head Mandrel.

FRAME ALIGNMENT

If the machine has been damaged in an accident, the frame portions must be checked for correct alignment. In the following paragraph, details are given of alignment checking for all parts of the frame (excepting the telescopic fork, which is dealt with in Section G).

Basic requirements for alignment checking are an engineer's checking table (surface area approximately 3 feet \times 5 feet), adjustable height gauge, (Vernier type preferable), two suitable "V" blocks, several adjustable height pillars, a set-square, and a mandrel, (as illustrated in Fig. E13).

FRONT FRAME

It is essential that after setting, or checking, the front frame lug centre line is in a plane perpendicular to the plane of the swinging fork pivot lug centre line. It is also essential, that the remaining tubes and lugs are in their relative positions within the stated limits of accuracy.

The method of checking the front frame is that of fitting securely an adaptor spindle, of the type shown in Fig. E13, to the head lug (See figs. E14 and E15). It is then required to support the spindle and head lug on a plane parallel to, and approx. 6 ins. (15 cm.) from, the checking table surface. For this purpose two "V" blocks, packing pieces, and two suitable "G" clamps will be required. At the other end of

the frame (swinging fork and rear frame removed) an adjustable pillar should be placed under the down tube adjacent to the swinging fork pivot lug (see Fig. E14). The height of the pillar can be determined by measuring the diameter of the tube which is to rest on it, halving the diameter and then subtracting this figure from the distance between the head lug centre line and table surface.

The frame centre line should now lie parallel to the checking table surface, if the frame alignment is correct.

To verify this, take height readings on the front down tube, top tube, and rear down tube. See Fig. E14 and E15. Permissible maximum variation is $\frac{1}{32}$ in. (0.75 mm).

Fit the swinging fork pivot spindle with the two outer bobbins and distance tube attached, and check the pivot lug for squariness, using a set square at the two location points as shown in Figs. E14 and E15.

Then, using a set square check that the two engine cradle tubes are aligned, by bringing the set square to bear on them at the front and rear.

Using a steel rule, or other suitable instrument, measure the hole centres, and compare the figures obtained with those given in Fig. E16.

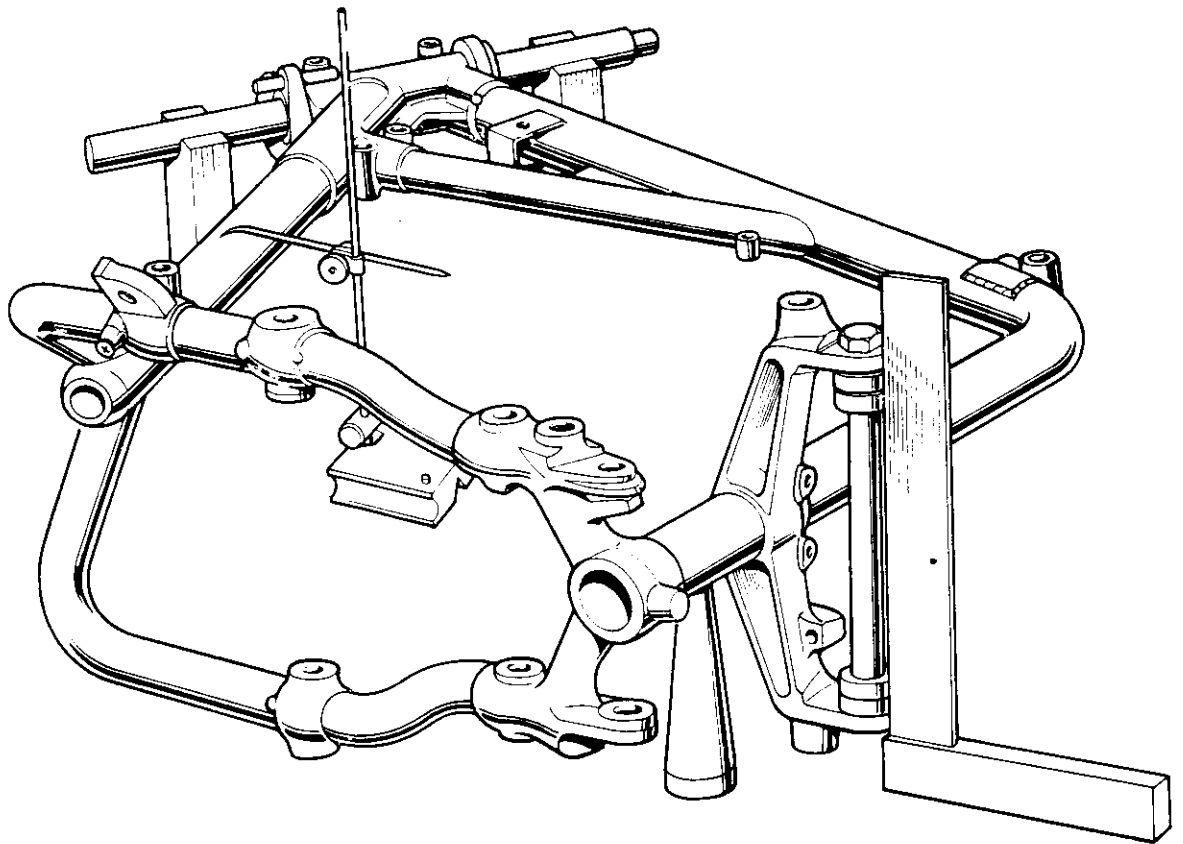


Fig. E14. Checking the front frame alignment

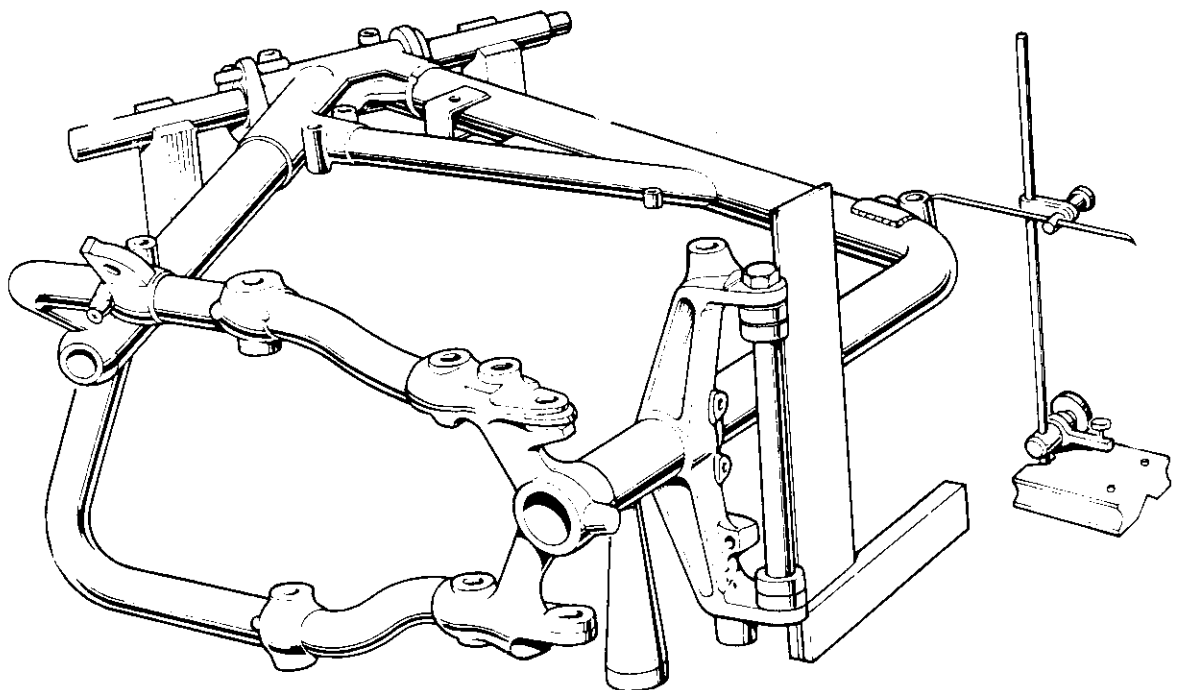


Fig. E15. Checking the front frame alignment

FRAME

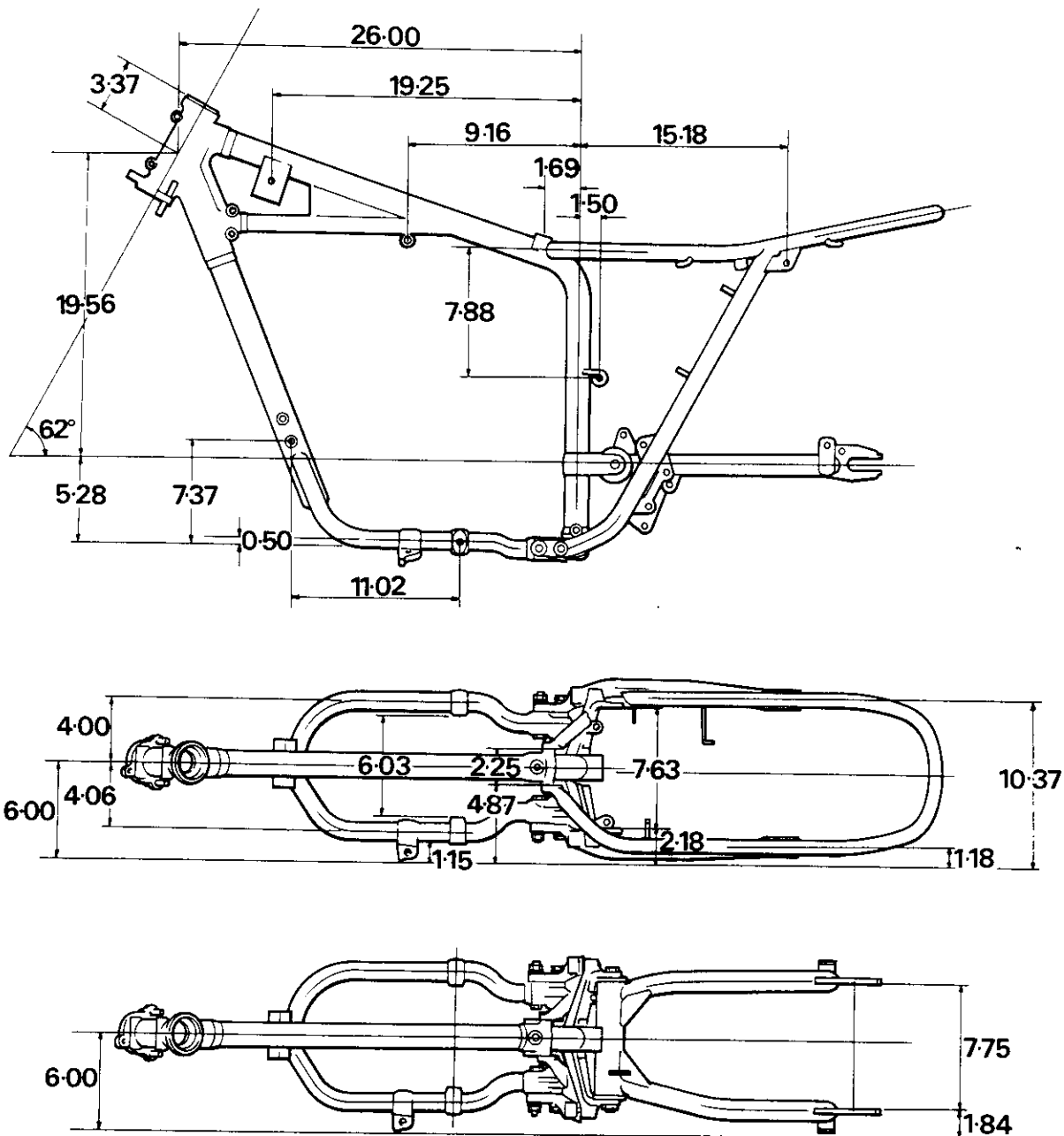


Fig. E16. Basic dimension of frame assembly (inches)

REAR FRAME

The rear frame basically serves to mount the rear suspension units and twinseat etc., and it is only alignment between the top suspension unit support brackets with those on the swinging fork that is of most importance. The best means of checking rear frame alignment is that of fitting it to the front frame and taking readings as indicated in the following paragraph.

FRAME ASSEMBLY

Securely bolt the rear frame to the front frame, and fit the swinging fork so that it can just be rotated by slight hand pressure. Mount the complete assembly horizontally on the checking table as described earlier, then take height readings at the swinging fork ends and top and bottom suspension unit mounting brackets, referring to Fig. E16 (b) and (c) for dimensions. These brackets should not be

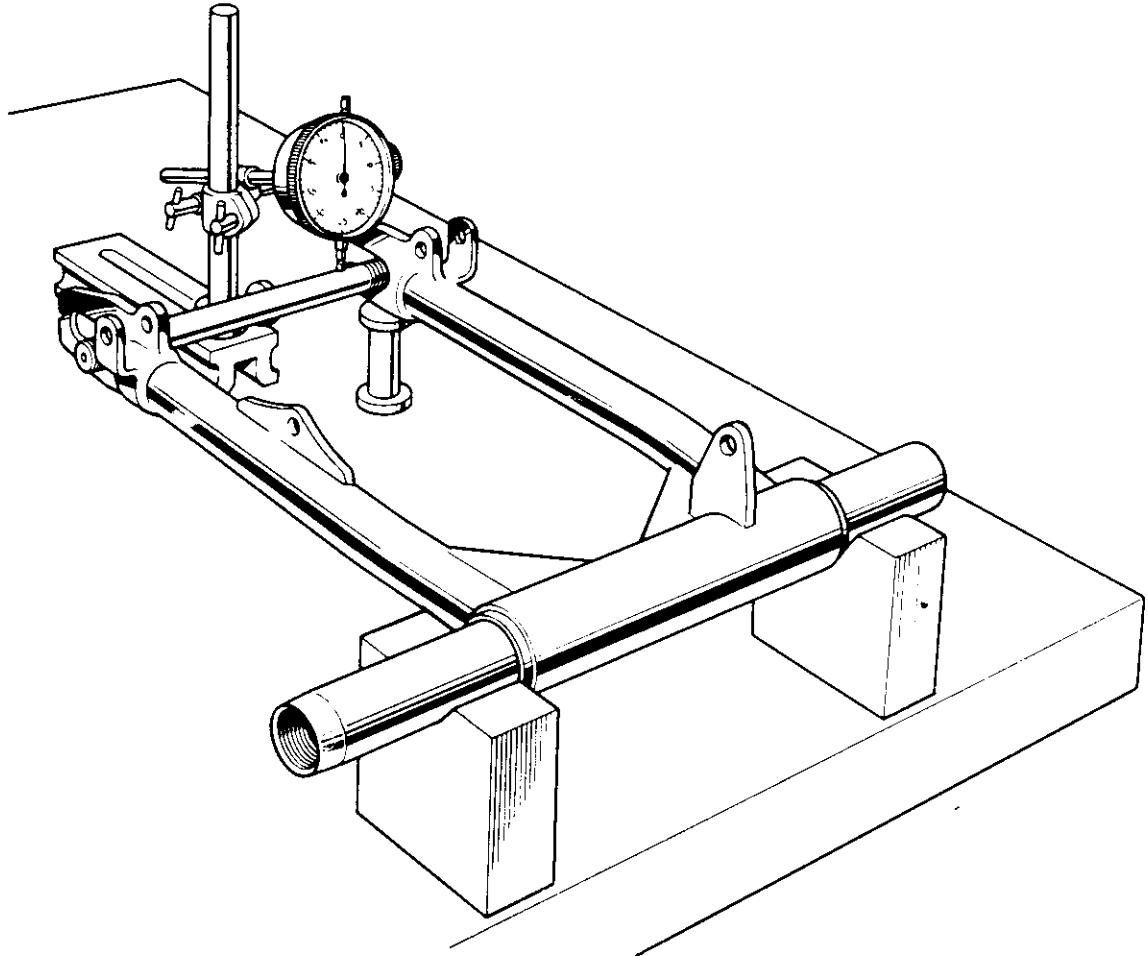


Fig. E17. Checking the swinging fork

more than $\frac{1}{4}$ in. (1.5 mm.), out of line otherwise the suspension units will be working under excessive stress.

SWINGING FORK

It is necessary to verify that the centre line of the pivot spindle is in the same plane as the centre line of the rear wheel spindle. To do this, first place a tube, or bar of suitable diameter, into the swinging fork bearing bushes, then mount the swinging fork on two "V" blocks, one either side, and clamp it lightly to the edge of the checking table. Fit the rear wheel spindle into the fork end slots or, alternatively, use a straight bar of similar diameter, then support the fork end so that the arms are approximately horizontal. Height readings should then be taken at both ends of the wheel spindle to establish any mis-alignment (Fig. E17).

Next, check that the distance between the fork ends is as given in "General Data".

It is now necessary to lever the fork ends in the correcting direction until the wheel spindle can be inserted and found to be parallel with the pivot bush centre line. To do this, a bar of about 4 ft. length by $1\frac{1}{4}$ in. will be necessary.

It is now that great care is required. Insert the bar at the end of the swinging fork adjacent to the suspension unit mounting brackets so that it is over the "high" fork leg and under the "low" fork leg. Exert gentle pressure at the end of the bar, then insert the spindle and re-check the alignment. Repeat this procedure using increased loads until the spindle height readings show that the swinging arm is now slightly misaligned in the opposite direction. A small leverage now applied from the other side, will bring the wheel back to parallel.

Note: Apply the leverage bar as near as possible to the suspension unit brackets, otherwise the tubes may become damaged. **DO NOT USE THE FORK ENDS.**

SECTION E13

FAIRING ATTACHMENT LUGS AND STEERING LOCK

FAIRING ATTACHMENT LUGS

The two lugs shown in Fig. E18 are fitted to facilitate mounting a fairing after the headlamp has been removed.

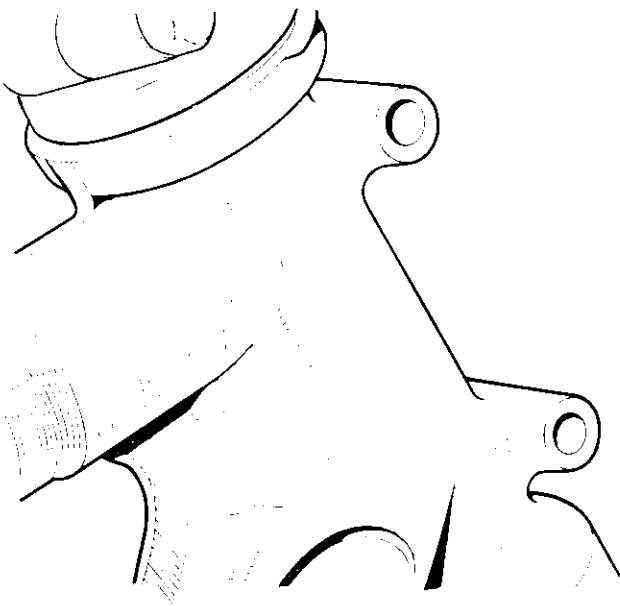


Fig. E18. Fairing attachment lug

STEERING LOCK

A barrel type steering lock is fitted into the lower fork yoke. If, for any reason, the lock is to be removed, a grub screw (see Fig. E19) must be removed, and the lock can be drawn out. Note, however, that a sealing disc is fitted into the lug over the grub screw, and this will have to be prised out to gain access to the screw. The slug is of lead, hammered into the screw hole, and should be renewed after re-fitting the lock.

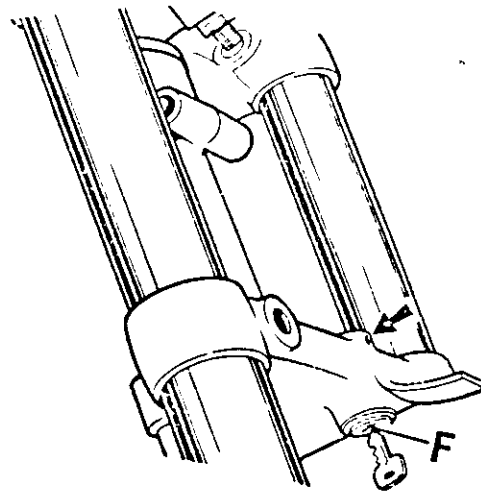


Fig. E19. Steering lock

SECTION E14

FITTING REPLACEMENT SEAT COVERS

Twinseats have a cover retained by "sprags" which are part of the seat pan and the edge is covered by a trim strip, retained by four clips.

When fitting a replacement seat cover it is **very important** first to soak the complete cover in hot water in order to soften the plastic so that it can easily be stretched into place. After soaking

wring out the excess water when it will be found that the cover can be stretched into place to give a neat fit without any wrinkles. This task is very difficult if this suggested method is not followed.

Ideally the seat should be allowed to dry out in a warm place before being put back into service.

SECTION E15

REPAIRS

Repairs covered in this section are simple operations requiring only a minimum of special tools. The type of repairs possible with these tools are those such as small dents to mudguards, caused by flying stones, or slight grooves which have not affected a large area or torn the metal. The tools required are shown below in Fig. E20.

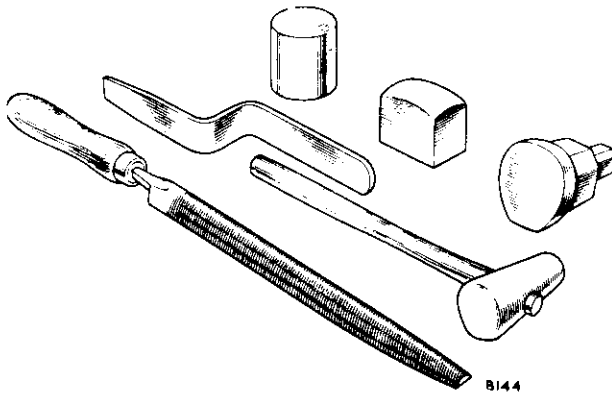


Fig. E20. Tools used for panel repairs

REMOVAL OF DENTS

To remove small dents a spoon and suitably shaped dolly block are required. A suitable spoon can be made from a file by grinding off the teeth, on one side, and polishing the surface. It will be necessary to carefully anneal the file before attempting to crank it to the shape shown in Fig. E21.

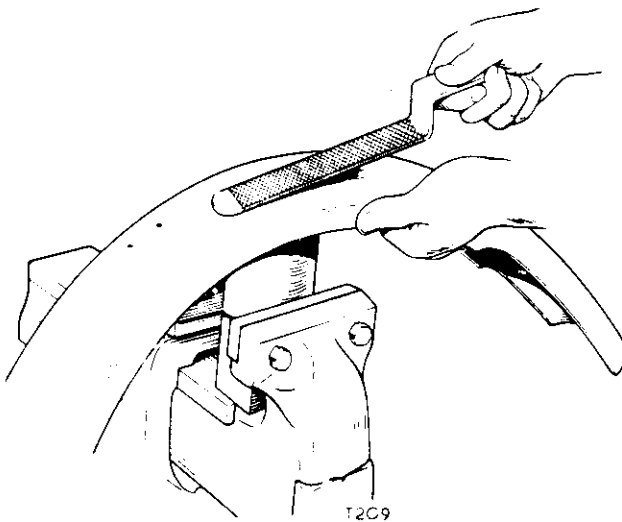


Fig. E21. Removing a dent with a dolly block and spoon

Place the dolly block underneath the panel then hammer the dent(s) carefully with the spoon until something like the original contour is achieved. Lightly file the surface to show any high spots there may be and use the dolly and spoon to remove them.

Note.—Do not file more than is necessary to show up the high spots. Care should be taken to keep filing to a minimum otherwise serious thinning of the metal will occur.

Where denting has occurred without resultant damage to the paint-work the dent(s) may be removed whilst the paintwork is preserved by careful use of a polished spoon and dolly block.

Dents which are comparatively larger may be removed whilst the paintwork is preserved by placing a "sandbag" against the outer surface and hammering the inside of the panel with a suitably shaped wooden mallet. A "sandbag" can be made from a piece of 18 in. square leather by folding it and packing it tightly with sand. Finally, finish off using a suitable dolly block and polished spoon as required.

Note.—It is not advisable to use a hammer because hammer-blows tend to stretch the surrounding metal, giving rise to further complications. Also, unless the aim is true, damage of a more serious nature may result.

Where a fuel tank has become damaged the repair work should only be entrusted to a competent panel beater.

SECTION E16

PAINTWORK REFINISHING

PAINT STRIPPING

Except in cases where a "touch-up" is to be attempted, it is strongly recommended that the old finish is completely stripped, and the refinish is carried out from the bare metal. A suitable paint stripper can be obtained from most paint stores and accessory dealers.

The stripper should be applied with a brush, and allowed approximately 10 minutes to react. A suitable scraper should be used to remove the old finish, then the surface cleaned with water and a piece of wire wool. Ensure that all traces of paint stripper are removed. If possible, blow out crevices with compressed air.

It is advisable to strip a small area at a time to avoid drying of the stripper and also to enable easier neutralizing of the stripper.

Finally, the surface should be rubbed with a grade 270 or 280 emery cloth to give a satisfactory finish, then washed off with white spirits or a suitable cleaner solvent.

PRIMING

A thin coat of cellulose primer must be sprayed on to the surface, prior to application of an undercoat or filler. Undercoat and filler will not adhere satisfactorily to bare metal. It is advisable to thin the primer by adding 1 part cellulose thinners to 1 part primer. Ensure that the primer is dry before advancing further.

APPLYING FILLER

Imperfections and slight dents in the surface may be built up with filler, but rubbing down with "wet and dry" abrasive paper should not be attempted until the undercoat has been applied.

Apply the filler with a glazing knife, in thin layers, allowing approximately 20 minutes for drying between each layer. After the last layer, allow filler about 6 hours (or over-night if possible) to dry. Heavy layers or insufficient drying time will result in risk of surface cracking.

UNDERCOAT (SURFACER)

Most cellulose undercoats (also called surfacers) will suffice for a base for TRIUMPH finishes. About two or three coats are required, and should be sprayed on in a thinned condition, using 1 part cellulose thinners to 1 part undercoat. Allow approximately 20 minutes between each coat.

If filler has been applied, the final layer of undercoat should be sprayed on after smoothing the surface with "wet and dry" abrasive, as mentioned below.

"WET AND DRY" ABRASIVE

After application of the undercoat, the surface should be rubbed down with 270 or 280 grade abrasive paper, used wet. An ideal method is to have a rubber block, approximately 3 in. x 2 in. x 1 in., around which to wrap the emery paper. However, this is only recommendable for flat surfaces; where rapid change of sections occur, a thin felt pad is more useful.

The abrasive paper should be allowed to soak in cold water for at least 15 minutes before use. A useful tip is to smear the abrasive surface of the paper with soap prior to rubbing down. This will prevent clogging, and should at least treble the useful life of the paper, if it is washed thoroughly after each rub-down.

When the surface is smooth enough, wash it thoroughly with water and dry off with a clean sponge.

If smoother surface than this is required, it can be given another layer of undercoat, and then the rubbing down procedure repeated using 320 or 400 grade of paper, depending upon conditions.

FINISHING

Before spraying on the finishing coats, the surface must be quite smooth, dry, and clean. It is important that conditions are right when finish spraying is to be carried out, otherwise complications may occur. Best conditions for outdoor spraying are those on a dry sunny day without wind. Moisture in the atmosphere is detrimental to paint spraying.

The first coat should be thinned in the ratio of 50% cellulose thinners to 50% paint. Subsequent coats should have a higher proportion of thinners as shown below.

	<i>Cellulose</i>	
	<i>Thinners</i>	<i>Paint</i>
1st Coat	50%	50%
2nd Coat	60%	40%
3rd Coat	70%	30%
4th Coat	80%	20%

Between each coat, the surface may be "flatted" by hand, with 320 or 400 abrasive paper as required.

Allow at least 10 minutes between each coat, and after the final coat leave overnight, or 24 hours if possible. For most purposes, the 2nd coat of finishing is more than adequate.

POLISHING

The final colour coat must be completely dry before cutting and polishing. Using a clean rag, rub down with brass polish, or fine cutting paste, and burnish to a high gloss, using a clean mop, before applying a suitable wax polish for protection and shine.

SECTION F

BRAKES, WHEELS, AND TIRES

DESCRIPTION	Section
THE DISC BRAKE	F1
MAINTENANCE	F2
THE DISC	F3
THE BRAKE PADS	F4
HYDRAULIC FLUID LEVEL	F5
FLUSHING THE HYDRAULIC SYSTEM	F6
BLEEDING THE SYSTEM (GENERAL)	F7
BLEEDING THE SYSTEM (SPECIAL NOTE, REAR BRAKE)	F8
MASTER CYLINDER/CONTROL LEVER BODY	F9
MASTER CYLINDER	F10
FRONT BRAKE CYLINDER	F11
REAR BRAKE CYLINDER	F12
STRIPPING AND REASSEMBLING BRAKE CALIPER... ..	F13
REPLACEMENT PARTS	F14
REMOVING AND REPLACING FRONT WHEEL	F15
REMOVING AND REPLACING FRONT WHEEL BEARINGS	F16
REMOVING AND REPLACING REAR WHEEL	F17
REMOVING AND REPLACING REAR WHEEL BEARINGS	F18
FRONT AND REAR WHEEL ALIGNMENT	F19
WHEEL BALANCING	F20
WHEEL BUILDING	F21
REAR CHAIN ADJUSTMENT	F22
REMOVING AND REPLACING TIRES	F23
SECURITY BOLTS	F24
TIRE MAINTENANCE	F25

SECTION F1

THE DISC BRAKE

The disc brakes are of a standard type, the disc being bolted to the hub, and the braking pads hydraulically operated from a caliper housing, bolted to the left side fork leg at the front wheel, and to the anchor plate on the right side of the rear wheel. Pipelines, (partly rigid and partly flexible), convey the operating fluid from the operating control to the caliper, the master cylinder and fluid

reservoir, in the case of the front brake, being combined in a unit on the handlebar. Caliper, pipelines, and master cylinder, etc., are of Lockheed manufacture. For the rear brake, the master cylinder is mounted on the right side chain stay, and is operated by the foot brake pedal. The fluid reservoir, in this case, is located beneath the twistseat.

SECTION F2

MAINTENANCE

Mechanical adjustment is not necessary, and the braking system is designed to be self adjusting; consequently, only minimal maintenance is required. The life of the brake pads will vary with mileage and operating conditions, but during this time, it should not be necessary to replenish the fluid level in the reservoir, hence the level will fall slightly as the brake pads wear. The fitting of new pads,

described on page F4, will restore the fluid to its original level.

Other essential maintenance is to the pipeline union nuts, all of which must be checked at regular intervals for signs of fluid leakage. The union bolt at the handlebar pipeline connection is concealed beneath a rubber cover (on U.S.A. models). The bleed nipple also requires checking for tightness.

SECTION F3

THE DISC

The ten inch diameter disc is made of close-grained cast-iron, with the braking surface hard-chrome plated. It should require no maintenance other than when renewal becomes necessary due to damage, such as excessive scoring.

To replace the disc, first remove the wheel. For the front wheel, see Section F15, and for the rear Section F17.

Unscrew the four securing nuts, and detach the disc. Check that the joint face on the hub, and also on the new disc, is completely clean, then fit the new disc

and tighten the nuts diagonally opposite to each other.

Replace the wheel, and attach a dial test indicator to the forkleg, and check the run-out on the disc. The maximum reading should not exceed .0035 in. (.089 mm). If it is outside the limit, the disc should be repositioned, in an attempt to obtain a more satisfactory combination of machining limits.

Excessive run-out of the brake disc moves the pistons back into the bores, and creates excessive lever travel when the brake is applied, thus the run-out must be kept to the specified minimum.

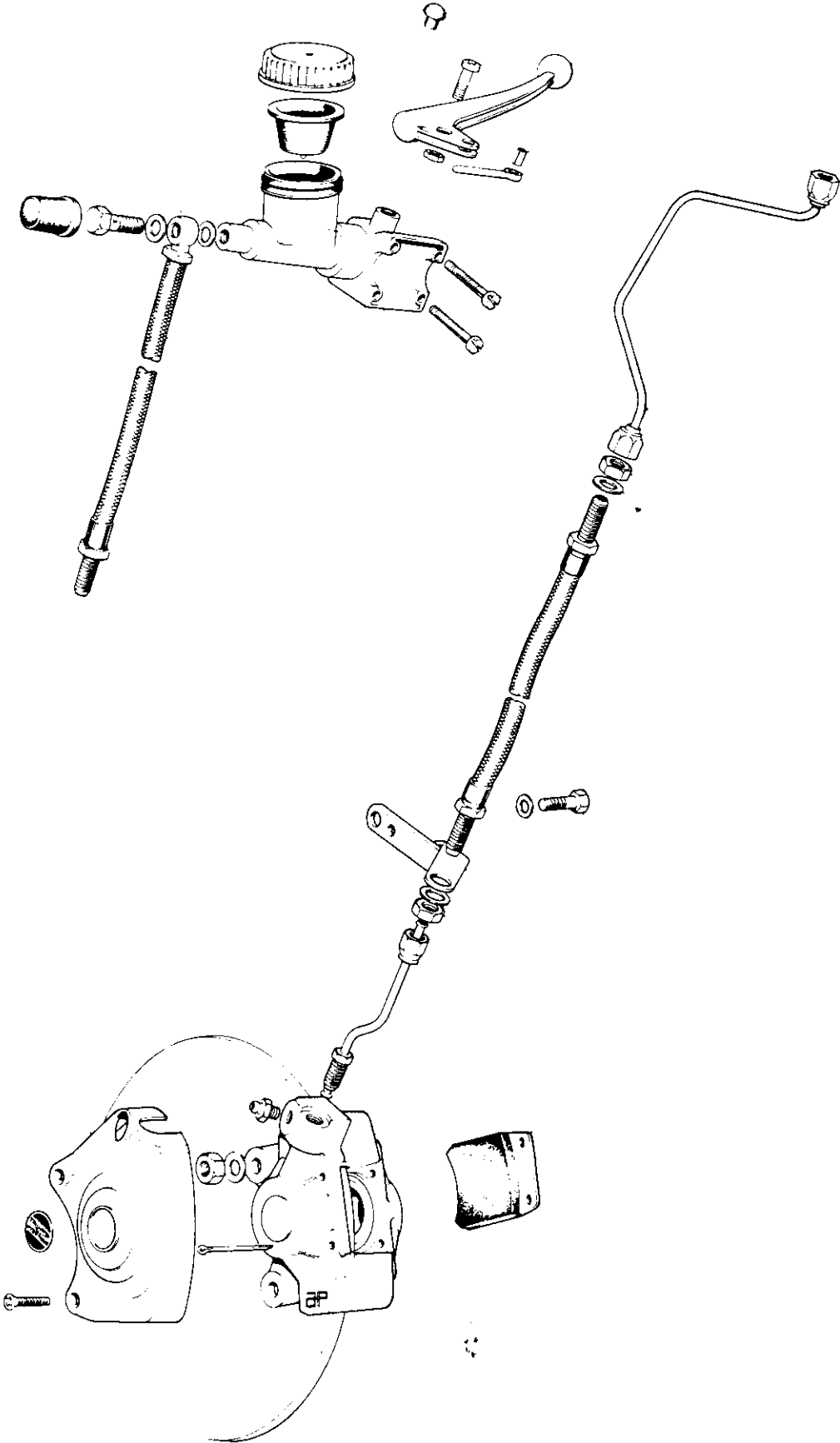


Fig. F1. Disc brake components (Front)

SECTION F4

THE BRAKE PADS

These will require renewal when the thickness of any part of the friction material has been reduced to a minimum $\frac{1}{16}$ in (1.6mm). This can readily be determined after removing the pads from the caliper, for which purpose it is not necessary to remove the wheel, although pad removal is made even more simple in the absence of the wheel.

First remove the cover from the caliper (retained by two screws). Then straighten and withdraw the two cotter pins B, (Fig. F2,) thus enabling the pads D to be extracted by hand.

Important: If the wheel is out of the forks, do not operate the handlebar lever, or foot pedal, after the pads have been removed.

If new pads are to be fitted, carefully prise the actuating plungers further apart, using a lever of a soft material (such as aluminium) in order to avoid damage to the plungers. The increased gap is necessary to allow sufficient clearance for the insertion of new pads.

Note: If during the life of the previous pads it had been found necessary to replenish the hydraulic fluid in the reservoir, the level will rise as the plungers are separated, and under extreme conditions, the fluid may overflow when the new pads are assembled. In this case the excess fluid must be treated with great care, since it will

damage cellulose paint work on contact. The level will then have to be corrected to that shown in Fig. F3.

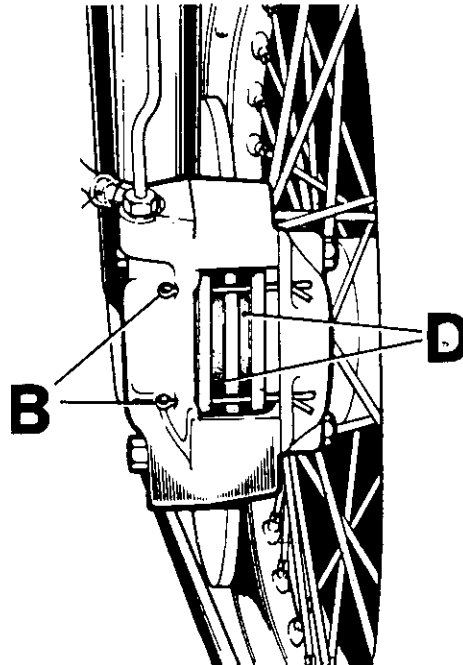


Fig. F2. Renewing the Brake Pads

SECTION F5

HYDRAULIC FLUID LEVEL

Removal of the reservoir screwed cap, and the rubber diaphragm E immediately beneath it, exposes the actuating fluid. The correct level, **when the pads are new**, is as illustrated in Fig. F3, and is given by a marker ring F on the wall of the reservoir.

Before replacing the diaphragm, lay it in an inverted position on a flat surface, and push the centre portion down until it touches the same surface. The diaphragm will remain set in this position and can then be refitted to the reservoir, where it will automatically adjust itself to any variations in oil level. Replace, and firmly tighten, the cap.

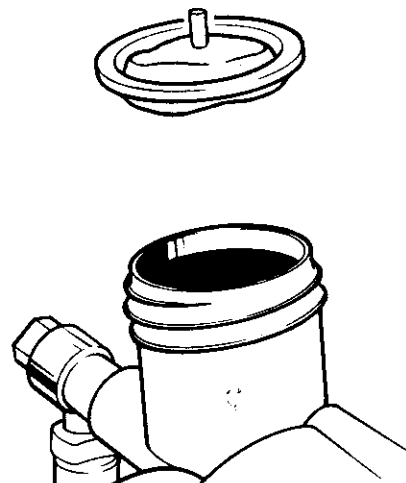


Fig. F3. Brake reservoir level

SECTION F6

FLUSHING THE HYDRAULIC SYSTEM

The capacity of the reservoir is such that, even when the brake pads are excessively worn, there is sufficient fluid retained in the reservoir to allow the brake to be operated, so that, under normal conditions, the fluid should not require replenishment. However, if the hydraulic system has been contaminated by foreign matter, or other fluids, it should be flushed out and refilled with new fluid. The system should be flushed out, in any case, once every three years.

Pump all the fluid out of the system, by opening the bleed screw, and operating the front brake lever a few times, after connecting a pipe to the bleed screw, in order to collect the fluid in a container. Fill the master cylinder reservoir with methylated spirits, and pump out through the bleed screw, in a manner similar to that previously described.

Having ensured that all the methylated spirit has passed through the bleed screw, replenish the master cylinder reservoir with the specified grade of brake fluid. The capacity is approximately 60 cm³ for the front brake, and 80 cm³ for the rear brake, and the special fluid to be used must conform with DOT 3, Federal Motor Vehicle Standards 116 (for U.S.A.). Lockheed Braking Fluid to specification 329 should be used in other parts of the world.

Finally, "bleed" the brake, as described in Section F7.

IMPORTANT NOTE.

If the system has been contaminated by a mineral oil, all rubber parts, including flexible hoses, must be replaced.

SECTION F7

BLEEDING THE SYSTEM (GENERAL)

Remove the cap and diaphragm from the reservoir and fill with the correct hydraulic fluid (see Fig. F3). Throughout the whole operation, maintain the fluid level at not less than $\frac{1}{2}$ full, to avoid any risk of introduction of air at this point.

Attach a rubber or other flexible tube firmly to the bleed nipple, (on the top right side of the caliper), as shown in Figure F4, submerging the free end of the tube in a quantity of braking fluid in a clean glass jar. The tube outlet must remain submerged throughout the whole operation, and if the operation is being carried out single handed, must also be looped as shown in the illustration Figure 4, to ensure that there is a "head" of fluid between the top of the loop and the bleed nipple, as a safeguard, to prevent air from being drawn back into the system when operating the control lever or pedal.

Unscrew the bleed nipple one complete turn (with the rubber tube still attached) and operate the lever or pedal steadily to its fullest extent. Any air in the system will be expelled through the tubing and be observed as bubbles rising in the jar. When the lever or pedal reaches the inner end of its stroke, tighten down the bleed nipple and allow the lever or pedal to return to its normal position without assistance.

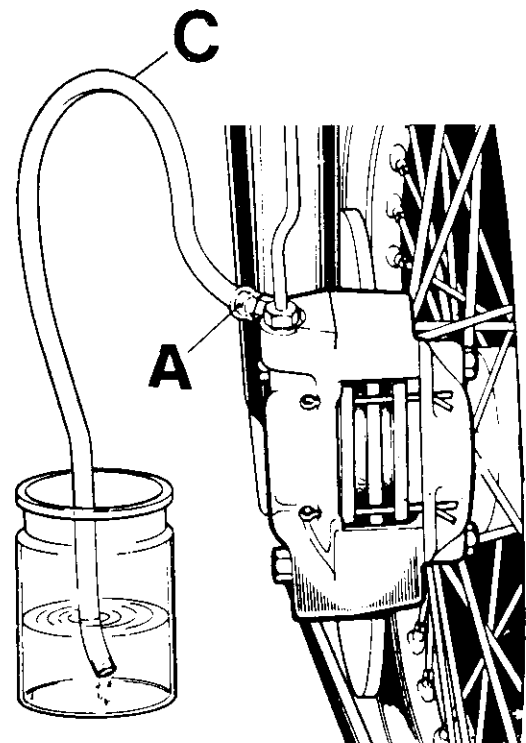


Fig. F4. Bleeding brake system

Repeat as many times as may be necessary until the fluid emerging from the tube into the jar is quite free of bubbles.

When this condition is satisfied, operate the control fully and **securely tighten the bleed nipple**. Only after this has been done should the lever or

pedal be released. Check the fluid level in the reservoir, as detailed earlier, and replace the diaphragm and the filler cap. **Special Note:** It is important that the bleed nipple and all pipe unions are securely tightened, otherwise these can be a source of oil loss.

SECTION F8

BLEEDING THE SYSTEM (SPECIAL NOTE, REAR BRAKE)

Before proceeding with the operation, withdraw the rear wheel spindle by an amount sufficient to release the torque arm which carries the caliper unit. The unit, still attached to the arm must be lowered to the ground, when the bleed nipple will be at the highest point of the fluid contained in the caliper.

This is essential, in order to avoid trapping air bubbles, which would reduce the efficiency of the brake.

During the operation of bleeding this brake, a **metal packing piece of the same thickness as the disc MUST be inserted between the brake pads.**

SECTION F9

MASTER CYLINDER/CONTROL LEVER BODY

The control lever assembly and the triple switch housing are independent units, clamped together on the handlebar by four screws, facing forward, and after these are removed, the units can be separated.

The stop-light switch is retained in the control lever body by a small screw, which must be removed, when the switch and its two leads can be withdrawn, but still attached to the triple switch assembly. The leads are soldered in position, and should not be disconnected unless the switch is to be renewed. Adjustment of the stop-light switch is by means of the small screw carried in a block of insulating material within the lever. The setting of the screw should be such that when the lever is fully released, the stop-light remains extinguished, but as soon as the lever is gripped and has moved by a small amount only the stop-light is illuminated.

The cylinder unit of the front brake is screwed into the control body, and is retained by a small socket screw. When the latter is slackened, the master cylinder and control lever body can be separated and attention given to either part as required. A service kit of parts is available for repairs of a comparatively minor nature, but if these are not sufficient to effect a repair, it will be necessary to replace the whole unit. When re-assembling, first fit the stop-light switch and securely tighten its locking screw. When the master cylinder is replaced, or a new one fitted, it should be screwed into the control lever body, until all play in the lever is only just taken up, and the socket screw tightened. Finally replace the four clamping screws. It will then be necessary to fill the reservoir with hydraulic fluid, and bleed the system, as described in Section F7.

Similar instructions apply to the rear brake unit.

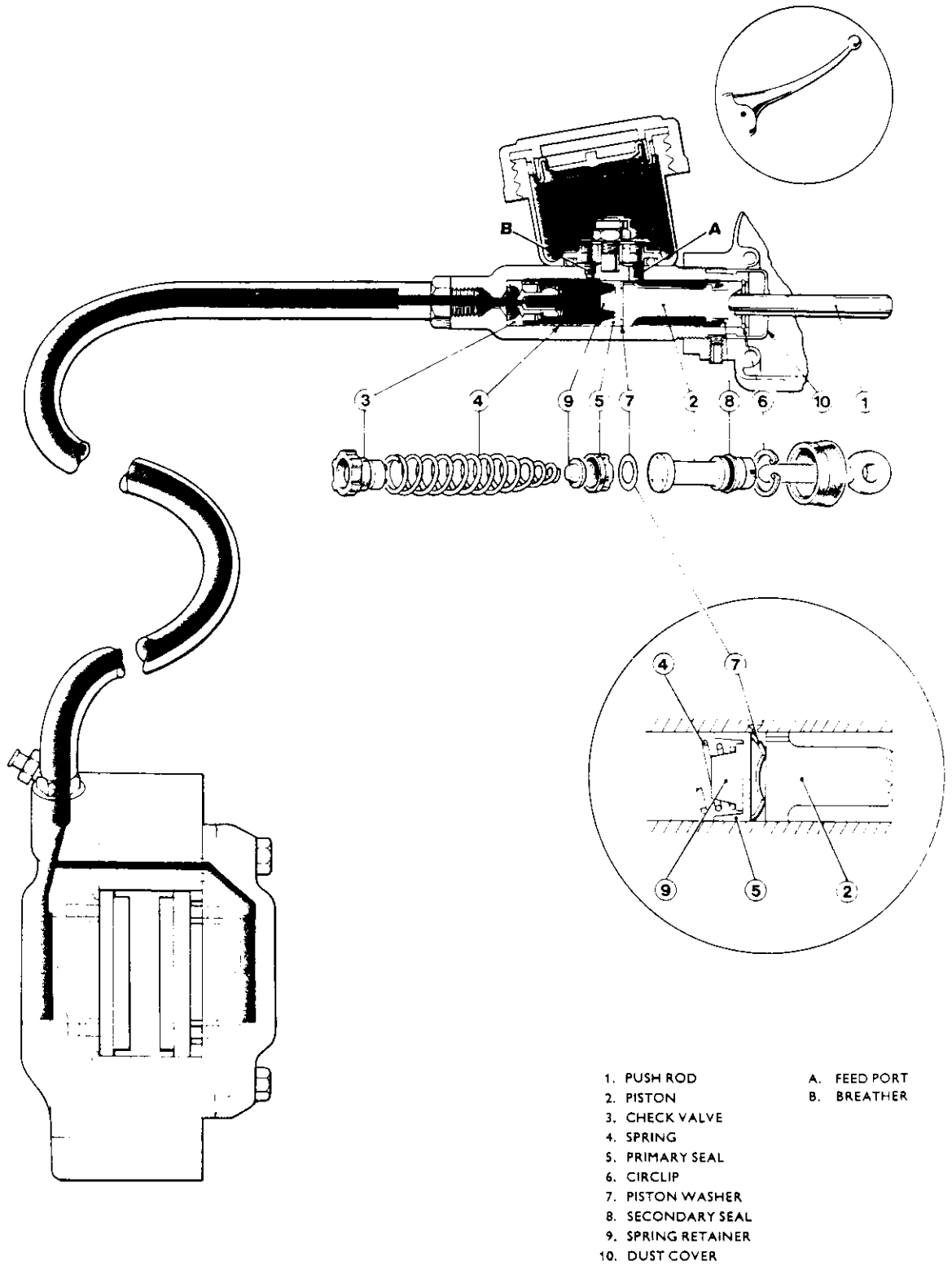


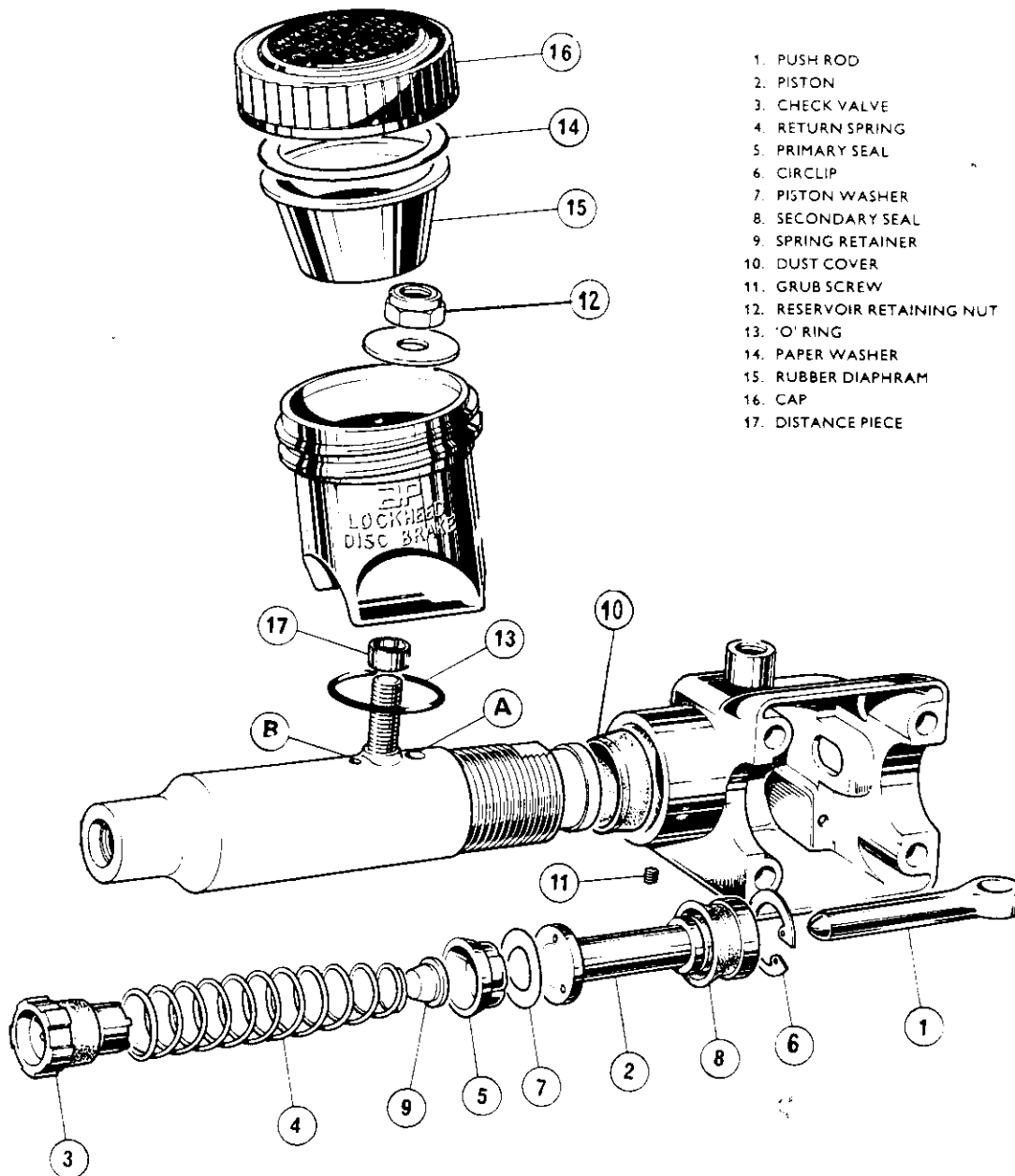
Fig. F5. Hydraulic flow diagram

SECTION F10 MASTER CYLINDER

The master cylinder consists of a fluid reservoir bolted to a cylinder body, which contains a piston, seals, and other parts, as shown in Fig. F6. With reference to this exploded view, and also the hydraulic flow diagram (Fig. F5), the operation of the brake assembly is as follows.

When the brake lever is operated, the push rod (1) moves the piston (2) down the bore. The displaced fluid in front of the piston is forced through holes in

the check valve (3), lifting the rubber seal clear of the holes, to provide an unblocked passage to the wheel cylinders. On releasing the front brake lever, the return spring (4) thrusts the piston (2) back faster than the fluid is able to return from the wheel cylinders. This creates a partial vacuum in the cylinder, which causes fluid to be drawn past the lip of the primary seal (5) and the main reservoir, via the main feed port (A), and the small feed holes in the head of the piston (2).



- 1. PUSH ROD
- 2. PISTON
- 3. CHECK VALVE
- 4. RETURN SPRING
- 5. PRIMARY SEAL
- 6. CIRCLIP
- 7. PISTON WASHER
- 8. SECONDARY SEAL
- 9. SPRING RETAINER
- 10. DUST COVER
- 11. GRUB SCREW
- 12. RESERVOIR RETAINING NUT
- 13. 'O' RING
- 14. PAPER WASHER
- 15. RUBBER DIAPHRAM
- 16. CAP
- 17. DISTANCE PIECE

Fig. F6. Exploded view of master cylinder

Meanwhile, fluid returning from the wheel cylinder lifts the check valves (3) away from its seat, and re-enters the cylinder. When the piston has fully returned, a small breather port (B) is uncovered, which allows a release of excess fluid to the reservoir and also compensates for contraction and expansion

of the fluid, due to changes in temperature. The purpose of the check valve (3) is to prevent the re-entry into the master cylinder of fluid pumped into the line during the "bleeding" operation, thus ensuring a fresh charge of fluid at each operation of the brake.

SECTION F11

FRONT BRAKE CYLINDER

Removal and dismantling procedure is as follows. First, drain the system of fluid (See Section F6). Remove the rubber hose from the end of the master cylinder. Remove the brake lever and push rod by unscrewing the pivot bolt. Unscrew the four retaining screws that hold the right switch console, and remove the master cylinder from the handlebars. Detach the reservoir bowl from the cylinder, by removing the attachment nut from the inside (See Item 12 Fig. F6). Note assembly of washer, spacer, and O ring. Remove the grub screw that locks the cylinder in position in the switch housing (See Fig. F6), and then unscrew the cylinder. Detach the rubber boot from the end of the cylinder.

Using the push rod (1), depress the piston in the cylinder, to relieve the load on the spring, and remove the circlip (6). Remove the piston (2), piston washer (7), primary seal (5), return spring (4), and check valve (3). The removal of the primary seal (5) may be simplified by applying gentle air pressure to the pipe connection at the end of the cylinder.

Remove the secondary seal (8) by stretching it over the flange of the piston. Renew all seals, and check the bore of the cylinder for deep score marks. If such damage is apparent, a new cylinder should be fitted.

It is important that all parts are meticulously cleaned with brake fluid before assembly. Do not use petrol, trichlorethylene, or any other cleaning agents to wash the parts.

Fit the secondary seal (8) onto the piston (2), so that the lip of the seal faces towards the head (drilled end) of the piston. Gently work the seal around the groove with the fingers, to ensure that it is properly

seated. Fit the spring retainer (9) onto the small end of the spring (4) and the check valve (3) onto the large end. Insert the spring assembly onto the cylinder bore, large end first. Insert the primary seal (5) into the cylinder bore, lip foremost taking care not to damage or turn back lip. The piston washer (7) should then be inserted into the barrel with the dished side towards the primary seal (5) followed by the piston, head (drilled end) innermost. Push the piston inwards with the end of the push rod, and refit the circlip (6) making sure that the circlip beds evenly in its groove. Refit the boot (10) by stretching it over the barrel. Refit the reservoir bowl, not forgetting the O ring, and test the cylinder by filling the reservoir, and pushing the push rod and piston inwards, allowing it to return unassisted. After a few applications, fluid should flow from the outlet connection at the cylinder end.

Fit the return spring. Empty the cylinder of fluid, and proceed to reassemble the cylinder barrel into the switch housing. At this stage the final position of the cylinder barrel in the housing must be determined. It will be noted, from Fig. F5, that the lip of the primary seal (5) must be $\frac{1}{8}$ in. behind the breather port, and the reservoir set at an angle of 10° to the vertical. The milled flats on the threaded end of the cylinder are machined relative to the 10° position, and the appropriate one must be used when assembly takes place.

The following method can be used to determine the correct linear position of the cylinder barrel.

- (a) Remove the reservoir from the cylinder.
- (b) Reassemble the front brake lever and push rod to the switch housing.
- (c) Screw the cylinder barrel into the switch housing, whilst holding the brake lever in the closed position, until it will screw no further.

- (d) Place one finger over the main feed port (marked 'A' in Fig. F6), and by blowing through the outlet end of the cylinder, it will be observed that no air will escape from the breather port ('B' Fig. F6).
- (e) Now unscrew the cylinder barrel until air is heard to escape from the breather port. At this point the port will have just become uncovered.
- (f) Unscrew the barrel one complete turn, and set the angle to 10°. The milled flat on the threaded end of the barrel must be located when the grub screw (Fig. F6) is being retightened, and will set the angle automatically.

Re-assemble the master cylinder to the handlebar, replenish the reservoir with fluid, and 'bleed' the system as described in Section F7.

SECTION F12

REAR BRAKE CYLINDER

In general principle the procedure to be adopted with the rear brake cylinder will be identical to that used for the front brake. In the case of the rear assembly however, the reservoir is

located under the dual seat being held in place by a bolt to the rear of a bracket forming part of the battery carrier.

SECTION F13

STRIPPING AND REASSEMBLING BRAKE CALIPER

Detach the protection cover from the caliper by removing the two cross head screws. Drain the system of fluid (See Section F6). Detach the feed pipe from the caliper, remove the two securing nuts at the forkleg, and withdraw the caliper from its mounting studs. Remove the two split pins that retain the brake pads, and pull them out.

No attempt should be made to remove the bridge bolts joining the two halves of the caliper. There is no necessity to do so, as all the servicing can be carried out without splitting the halves. In addition, the bolts are tightened to a critical torque loading. If, possibly as the result of an emergency, it becomes necessary to split the brake caliper, check that the fluid channel seal is undamaged, before reassembling. The caliper and bridge bolts should be thoroughly clean, and dried, prior to reassembly, and naturally, the caliper itself must be spotlessly clean. The bridge bolts should be tightened to a torque loading of 35/40 foot pounds (4.8-5.5 kg.m). After reassembling, the brake caliper should be checked for fluid tightness under maximum brake lever pressure.

The forgoing procedure should be looked upon as a temporary expedient, and the caliper should then be returned to the manufacturers for overhaul, at the earliest opportunity.

Service the rubber seals as follows, referring to the exploded view in Fig. F7. A rubber sealing ring (1) is fitted in a groove machined in each piston bore, to seal off the hydraulic fluid. A "U" shaped rubber dust seal (2) having two wiping edges, and housed in a metal container (3), is pressed into the open end of the piston bore, to prevent the ingress of dust from the brake pads.

The dust seal (2), together with its retainer (3), must be renewed each time they are removed from the piston bore. When the rubber seal (1) is worn or damaged it must be renewed. Before installation, the seals should be lubricated with Lockheed disc brake lubricant. The movement of the pistons (4 and 5), within their respective bore, extrude the rectangular rubber seal (1) from its groove. On releasing the brake lever, the hydraulic pressure collapses, and the rubber seal (1) retracts the pistons (4 and 5) a pre-determined amount, thus maintaining a constant clearance between the brake pads and the brake disc, when the brakes are not in use.

To remove the rubber seals, prise out and discard the dust seal (2 and 3) from the open end of each piston bore, by inserting the blade of a blunt screw-priver between the seal and retainer. Eject each piston from their bores by applying compressed air to the fluid inlet. Lift out and discard the sealing

rings (1) from the grooves in the piston bores, by inserting a blunt screwdriver under each ring, taking care not to damage the grooves.

Dry the new sealing rings (1) and smear them with Lockheed disc brake lubricant. Refit them into the groove of each piston bore, so that the large side is nearer the open end of the bore. Gently work the sealing rings into their respective grooves with the fingers, to ensure correct seating. Dry the pistons, and coat with Lockheed disc brake lubricant. Offer up the pistons, closed end first, squarely to the bores in the caliper, and press the pistons fully

home. Dry the dust seals, and coat with Lockheed disc brake lubricant. Fit a dust seal into a metal retainer, and position both squarely in the mouth of one piston bore, with the dust seal facing the bore. Press the dust seal into the mouth of the piston bore, using a "G" clamp and support plate, until its outer edges are flush with the bore. Repeat with the second dust seal and retainer. Fit new brake pads (See Section F4). Refit the brake caliper. Reconnect the hydraulic feed pipe, and "bleed" the system, as in Section F7/8. Refit the protection cover.

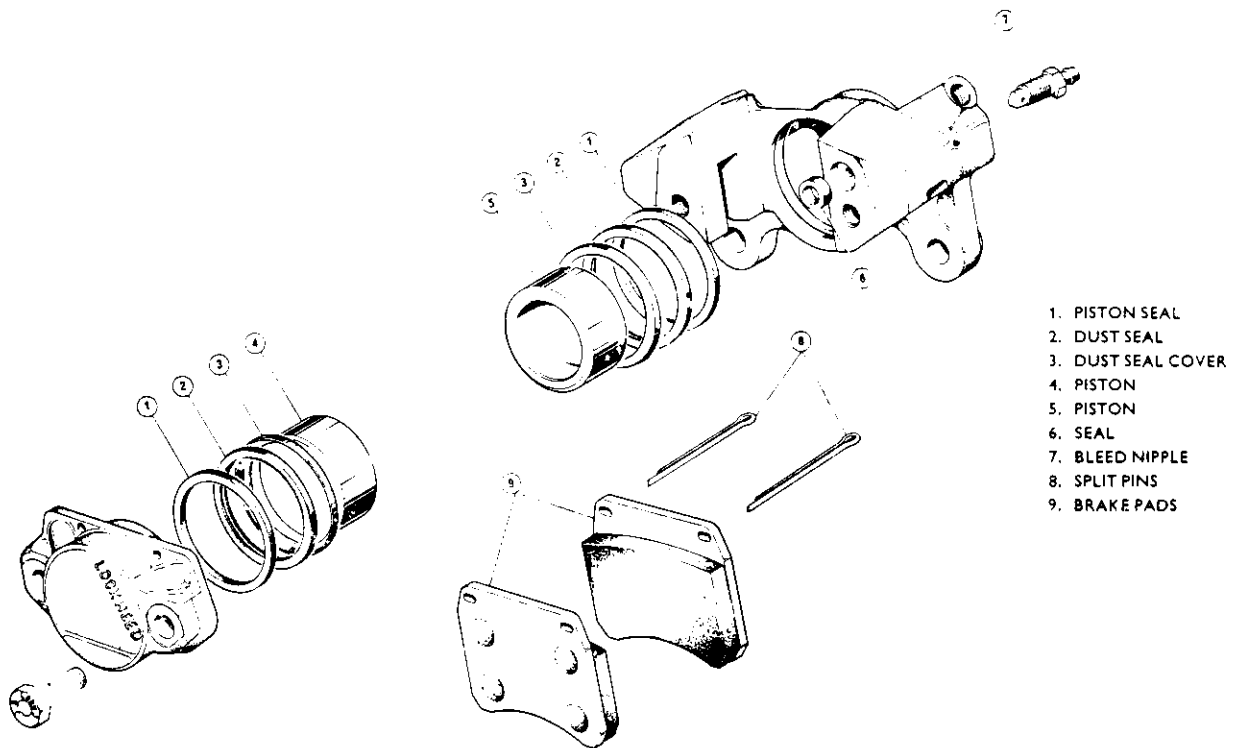


Fig. F7. Front and Rear Brake Caliper

SECTION F14

REPLACEMENT PARTS

Operation of the brake causes high pressure in the pipeline and other components, and it is therefore essential that when any parts are renewed, manufacturers components only are fitted. Copper piping must not be used as a substitute for the standard product, and the flexible pipes must also

be to the manufacturers specification. The use of incorrect components, materials, or hydraulic fluid, may lead to brake failure, with possible serious consequences, and also invalidates the warranty.

SECTION F15

REMOVING AND REPLACING THE FRONT WHEEL

Place the machine firmly on the centre stand. For preference, have available some form of support which can be placed underneath the exhaust pipe assembly below the crankcase, once the wheel has been removed.

Remove the bolts which secure the bottom mudguard stay to the fork end caps. Next, take off the four nuts and washers holding each cap. It is most important to note that these caps must be refitted to the side of the fork from which they are removed.

Having removed the caps, lift the fork and mudguard assembly, which should allow the wheel to drop clear of the fork ends.

At this stage, a support, if available, should be placed under the exhaust pipes below the crankcase.

It is most important that the front brake lever is not operated whilst the wheel is out of the fork. The insertion of a packing piece between the brake pads is recommended.

Refitting the wheel is quite straight forward. It may be advisable to use a screwdriver or some similar implement to gently hold the brake pads apart whilst entering the disc. Replace the caps on the fork ends, adding the washers and nuts, and tightening the nuts finger tight only at this stage. The nuts on the left side should then be fully tightened. (See torque figures in General Data), prior to tightening those on the right. This ensures correct alignment of the spindle with the left fork leg. Replace the bolts securing the bottom mudguard stay.

Important. Before using the machine, apply the brake several times to restore brake pressure, and check that it functions normally.

SECTION F16

REMOVING AND REPLACING FRONT WHEEL BEARINGS

Remove the front wheel (See Section F15). Unscrew the wheel spindle fixing nut from the left side, and then unscrew the retaining ring with service tool 61-7024 (Right hand thread). The left bearing can now be removed by driving the wheel spindle through the right side. Withdraw the inner grease retaining disc from the left side. To remove the right side bearing, spring out the circlip and insert the wheel spindle from the left side, and drive the bearing out complete with inner and outer grease retaining plates.

Fully clean all parts in kerosene (paraffin). Clean and dry the bearings thoroughly. Compressed air should be used for drying out the ball races. Test for end float and inspect the balls and races for any signs of pitting. If there is any doubt about their condition, the bearings should be renewed.

To refit the bearings first insert the right grease retainer, bearing and outer dust cap, using a liberal amount of grease (See Section A2). Refit the spring circlip and insert the shouldered end of the wheel spindle from the left and using it as a drift drive the bearing and grease retainer until they come up to the circlip. Re-insert the spindle the opposite way round and refit the left hand grease retainer disc. Drive the left bearing into position well smeared with grease then screw in the retainer ring (right hand thread) until tight, using Service tool No. 61-7024. Tap the spindle from the right to bring the spindle shoulder up against the left bearing. Replace the spindle fixing nut and re-tighten firmly. (Refer to Fig. F8 for layout and identification).

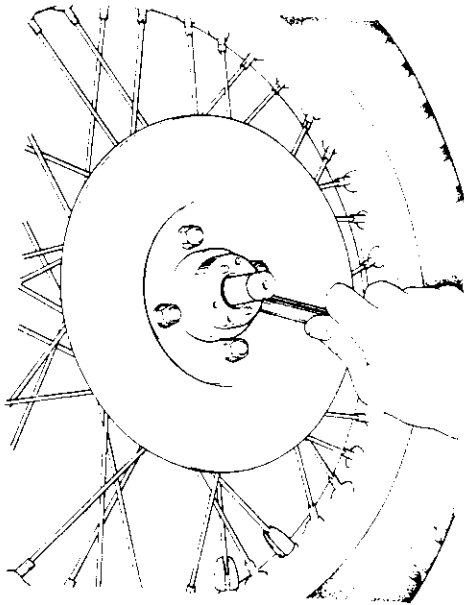


Fig. F8. Removal of left side bearing lock ring



Fig. F9. Exploded view of front wheel bearing arrangement

SECTION F17

REMOVING AND REPLACING REAR WHEEL

Place the machine on its center stand. It will be found helpful to place stand on a thick board or block, so as to provide additional height. With a gear engaged, remove the chain connecting link. Take the chain off the rear chainwheel, but do not remove it from the transmission (gearbox) sprocket, so as to assist replacement. The speedometer driving cable should then be disconnected at the speedometer gearbox.

Remove the spindle nut (on the right side of the machine), and partly withdraw the spindle from the opposite side, until its end clears the swinging arm on the right side. This will release the chain adjuster and the brake torque arm, complete with brake caliper. Steady the brake torque arm as it is freed, as it will drop down. The wheel, complete with its spindle and other components on the left side, can then be extracted and lowered to the ground.

It is most important that the brake should not be applied whilst the wheel is out of the fork, otherwise the pistons behind the brake pads may be

forced out of position. To avoid this condition, a packing piece should be inserted between the brake pads.

Care should also be taken not to disturb the setting of the chain adjusters. Stand at the left side of the wheel, facing across the machine, which should be tilted towards the operator. Reach over the seat and take the wheel out rearwards, to the right of the machine.

Replace in reverse order, taking care split link is fitted with closed end facing forward on top run of chain. It is also important to ensure the driving dogs on the speedometer gearbox are correctly mated with the slots in the drive ring.

After replacing the wheel, check the chain adjustment and wheel alignment, to ensure that all is in order.

IMPORTANT. Before using the motorcycle again, apply the brake several times, to restore full brake pressure, and check that it is functioning correctly.

SECTION F18

REMOVING AND REPLACING REAR WHEEL BEARINGS

Take out the wheel, as described in Section F17. Draw off the spindle and fittings from the left side. Using a long Tommy bar or drift, insert it from the right side of the wheel (brake disc side), tap out the left side spacer. If the drift is then inserted from the other side of the hub, the right side spacer can be removed in a similar manner.

Unscrew the speedometer drive ring from the left side of the hub, possibly using a piece of strip steel, or something similar.

Using a pair of sharp nosed pliers, take out the circlip on the right side of the hub. A piece of round steel, $\frac{3}{8}$ " diameter, preferably with a chamfered leading edge, can be inserted from the chain-wheel side of the hub. This should locate in the inner distance piece, and this item, together with the bearing and inner and outer dust covers can be drifted or pressed from the hub assembly.

The left side bearing and grease seal can then be driven out from the other side of the hub.

Before commencing reassembly, check the condition of the dust covers, grease retainer and distance

pieces etc. It is advisable to replace any damaged parts. Clean the bearing housings.

First fit the grease retainer to the threaded end of the hub, dished face inwards. The periphery of the larger bearing should then be smeared with Loctite, and the bearing pressed into the hub, until it locates on the inner shoulder. It is essential that the bearing be kept square during the pressing operation. Press in the spacer sleeve.

From the other side of the hub, fit the tapered inner distance piece, large end first, a dust cover with the flat side inwards, the bearing (with the periphery smeared with Loctite), the remaining dust cover with the flat outwards, and the right side spacer sleeve. Once again, it is important to ensure that the bearing is square when being pressed home into the hub. Finally, refit the circlip, having ensured that the groove into which it fits is completely clear. Make sure that the circlip is securely located. Screw home the speedo drive ring on the other side of the hub, making sure that the driving slots for the speedometer gearbox are not damaged in the process.

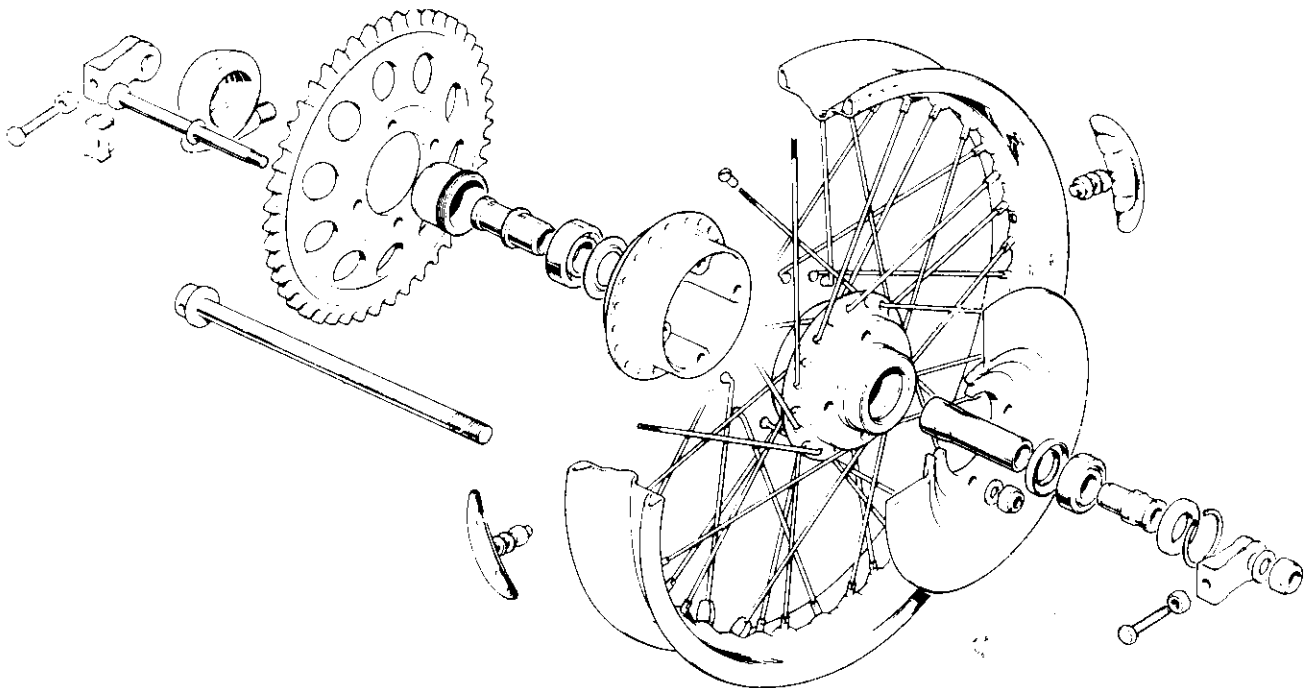


Fig. F10. Rear Wheel Assembly

It is advisable to lightly grease the wheel spindle when replacing, so as to facilitate future withdrawals of this item.

Refer to Section F17 regarding wheel replacement.

The chainwheel and the brake disc are retained by four long studs which pass through the hub. The

hub itself consists of two halves which are pressed together during production. It is not advisable to separate the two half hubs, otherwise difficulty may be experienced with spoke tensioning etc. The chainwheel or the brake disc can be removed without interfering with the hub assembly itself.

SECTION F19

FRONT AND REAR WHEEL ALIGNMENT

When the rear wheel has been fitted into the swinging arm, it must be aligned correctly with the front wheel, for otherwise misalignment will cause steering to be affected adversely and both tires and chains to wear excessively.

Check alignment with the motorcycle on the centre stand. Tie a 7ft long (20 m) length of string round the section of the tire and draw the free end through between the centre stand and frame, thence to the rear wheel. This provides, in effect, a straight edge as shown in Fig. F11. Draw the string taut so that it is in a straight line from end to end. For the wheels to be in line the string must touch both tire walls at two points as shown. Any correction should be made at the right side adjuster.

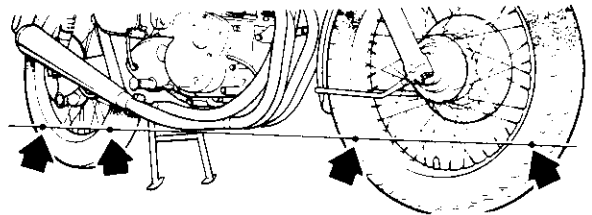


Fig. F11. Checking the wheel alignment

SECTION F20

WHEEL BALANCING

When a wheel is unbalanced, it is often due to variations in weight distribution in the tires, which are usually marked on the wall with a white spot(s) to indicate the lightest part. At moderate speeds, an unbalanced wheel may not be noticed, but at high speeds, however, the unbalanced forces can seriously effect the handling of the machine, more especially if the front wheel is affected.

Wheel balancing can be achieved by fitting standard one ounce and half ounce weights, as required. All front wheels are balanced complete with tire and tube before leaving the factory but it is advisable for the balance to be checked after the initial stiffness of the wheel bearings has been eliminated, following the break-in process. If for any reason the tire is removed it should be replaced with the white balancing "spot" level with the

valve. If a new tyre is fitted, existing weights should be removed and the wheel re-balanced, adding weights as necessary until this condition is achieved. A wheel is in balance when, if it is turned gently and released, it shows no tendency to stop in any particular position. Make sure that the brake is not binding while the balancing operation is being carried out.

With the wheel clear of the ground, turn it gently and allow it to stop. Mark the top of the wheel or tire and repeat two or three times to check.

If the wheel stops in the same place each time, extra weight must be added at the marked spot.

Next, ascertain how much weight is required by adding small pieces of modelling clay to the spoke

F

BRAKES, WHEELS AND TIRES

nipples and recheck as above until the wheel shows no tendency to stop in any particular position.

Balance weight(s) of exactly the same weight as the modelling clay must be attached to the spokes at the spot originally marked as shown at A Fig. F12.

If security bolts are to be used they must be fitted before balancing.

For hard road use it is considered necessary for the rear wheel to be balanced, and if this is being carried out, the chain must be removed from the sprocket. Make sure that the spring clip is replaced correctly.

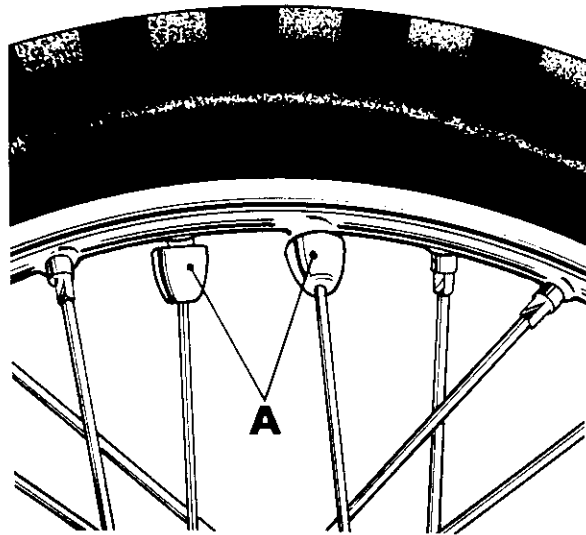


Fig. F12. The attachment of the balance weights.

SECTION F21

WHEEL BUILDING

Wheel building or adjustment to the spokes to realign the wheel rim should only be undertaken by a specialist and the following information is for his guidance.

The front wheel has twenty 10swg, 80° head angle outer spokes and twenty 10swg 96° head angle inner spokes, whilst the rear has twenty 10swg 96° head angle inner spokes, ten 10swg 75° head angle spokes, outer RH and ten 10swg 80° spokes outer LH

The main point to remember is that all Triumph wheels are built with the inside spokes on the brake drum, or disc side, taking the braking strain. This means that the inside spokes on that side are in tension when the brake is applied in the direction of a forward motion.

A checking gauge suitable for Trident wheels can be made from two pieces of mild steel bar, as shown in Fig. F13 and this should be used to register from the hub to the wheel rim edge using the dimensions shown in the following chart. In the case of the rear wheel, use the hub brake disc face for checking; on the front wheel, dimension from the dummy disc facing.

WHEEL	RIM SIZE	DIMENSION POINT	DIMENSION	
			IN.	MM.
FRONT	WM2	DUMMY DISC FACE	$\frac{15}{32}$ "	12.7
REAR	WM3	DISC FACE	$\frac{1}{2}$ "	11.9

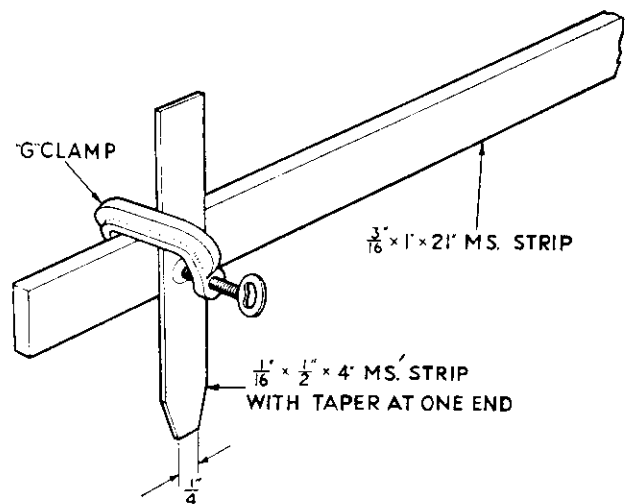


Fig. F13. Suggested wheel building gauge.

SECTION F22

REAR CHAIN ADJUSTMENT

Any adjustment of the rear chain must be made with the motorcycle on its centre stand. Movement of the wheel is controlled by adjuster A at each end of the spindle, which must first be released by slackening the nut on the right side.

The adjuster bolts C must be tightened by the same amount, after releasing locknut D, in order to preserve chain alignment, until the total free play at the centre of the chain run is $\frac{3}{4}$ ". Be sure to tighten the spindle nut. Movement of the wheel does not effect the brake.

Note: Before using the motorcycle, apply the brake several times and check that it functions normally.

Wheel alignment.

If the wheel alignment was correct originally, and the adjuster nuts were tightened equally, the wheels should remain in alignment. If in doubt, check as described in Section F19.

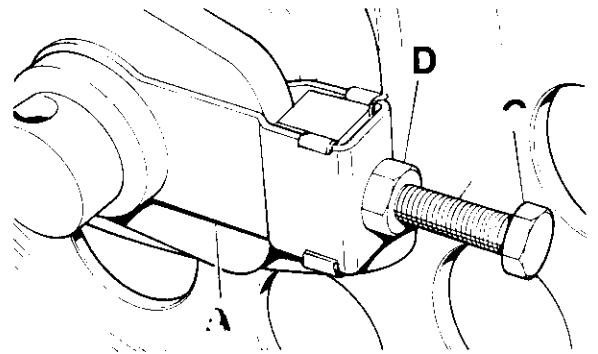


Fig. F14. The rear chain adjusters.

A positive oil feed to the rear chain is taken from the return side of the oil tank. Adjustment of the rate of flow is made by removing the tank cap and rotating a screw which will be observed in the neck. Turn the screw clockwise to reduce the flow and anti-clockwise to increase it. (See Fig. A12).

SECTION F23

REMOVING AND REPLACING TIRES

General

There are a few facts about tires which should be thoroughly understood:—

- (1) The beads have wire cores which cannot be stretched over the rim flanges without damage.
- (2) Removal and replacement will be simplified if the beads are pressed right down into the well of the rim, except at the point being "worked". The well is the centre section.
- (3) The tire beads will slip over the rim easily and damage will be avoided, if the beads and the levers are lubricated with soapy water.

Tire Removal

Unscrew the cap and then the valve core to deflate the tire.

If a removal tool is not available, depress the centre pin of the valve and keep "treading" the tire to expel the air.

Insert a lever at the valve position and whilst carefully pulling on this lever, press the tire bead into the well of the rim diametrically opposite to the valve position (See Fig. F15). Insert a second lever close to the first and prise the bead over the rim flange. Remove the first lever and reinsert a little further round the rim from the second lever. Continue round the bead in steps of two to three inches until the bead is completely away from the rim. (Fig. F16).

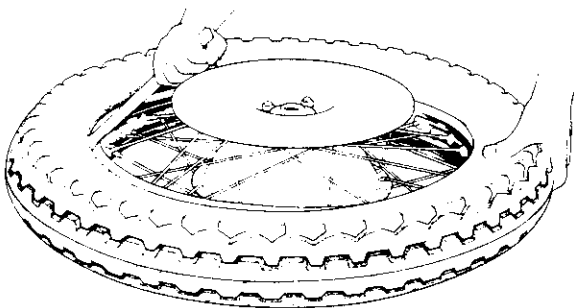


Fig. F15. Removing the first bead of the tire. Lever inserted close to valve, whilst bead is pressed into the well on opposite side of wheel.

Take care when inserting levers, not to pinch the inner tube as this will result in a puncture.

Push the valve out of the rim and then withdraw the inner tube. To completely remove the tire first stand the wheel upright and then insert a lever between the remaining bead and the rim. The tire should be easily removed from the rim as shown in Fig. F17.

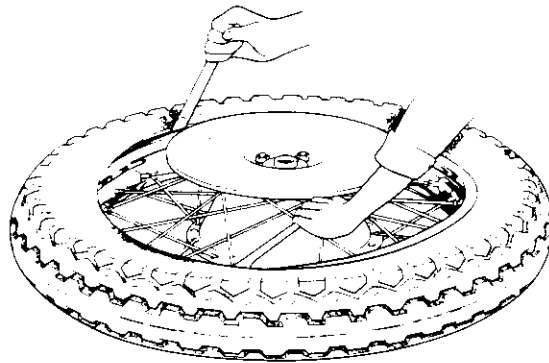


Fig. F16. Removing the first bead of the tire using two levers.

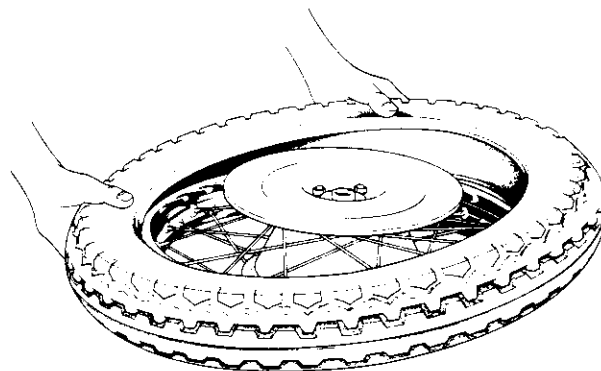


Fig. F17. Final removal of the tire

Tire Replacement

Before a tire (new or used) is replaced, it should be carefully checked inside and outside for loose objects or nails, flints, glass and cuts. Do not forget that although there may be nothing visible outside, there could be a nail projecting inside.

Remember that when replacing the tire, it is very easy to cause another puncture by nipping the inner tube with the levers, unless great care is exercised.

Some new tires have balance adjustment rubbers inside the casing. **They are not patches and should not be disturbed.**

When there is a white spot(s) near the bead it should be placed at the valve position or, if two security bolts are fitted, midway between the bolts. If one security bolt is fitted the white spot(s) should be located at this position.

If the spokes have been tensioned, or renewed, they must not project through the nipples. File flush any that are showing through.

First place the rim band into the well of the rim and make sure that the rough side of the band is fitted against the rim and that the band is central in the well. Replace the valve core and inflate the inner tube sufficiently to round it out without stretch. Dust it with french chalk and insert it into the cover with the valve located at the white "balancing spot" leaving the tube protruding outside the beads for about four inches either side of the valve (Fig. F18). At this stage it is advisable to lubricate the beads and levers with soapy water.

Squeeze the beads together at the valve position to prevent the tube from slipping back inside the tire and offer the cover to the rim, as shown in Fig. F19 at the same time threading the valve through the valve holes in the rim band and rim. Allow the first bead to enter the well of the rim and the other bead to lie above the level of the rim flange.

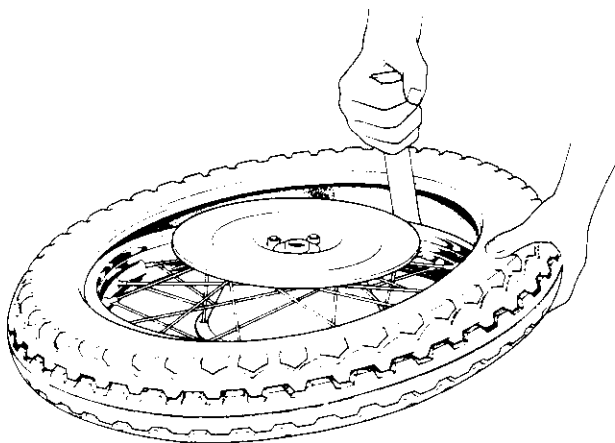


Fig. F20. Levering the first bead onto the rim

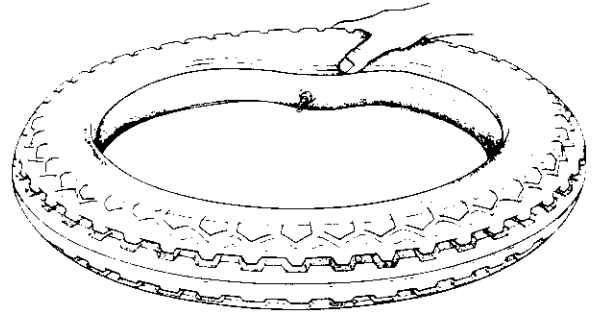


Fig. F18. Cover and tube assembled ready for fitting to the wheel

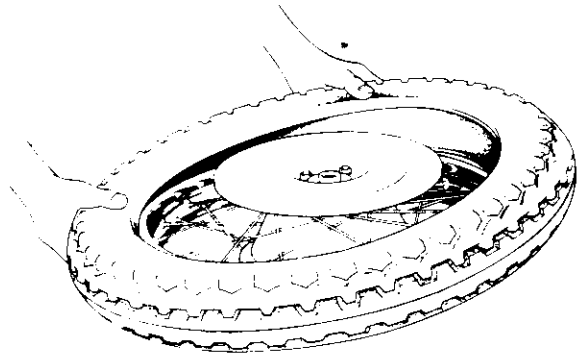


Fig. F19. Refitting the tire to the wheel.

Working from the valve, press the first bead over the rim flange by hand, moving forward in small steps and making sure that the part of the bead already dealt with, lies in the well of the rim. If necessary use a tire lever for the last few inches, as shown in Fig. F20. During this operation continually check that the inner tube is not trapped by the cover bead.

Turn the wheel over and check that the bead is concentric with the rim before proceeding further.

Reverse the wheel again and press the upper bead into the well of the rim diametrically opposite the valve.

Insert a lever as closely as possible to the point where the bead passes over the flange and lever the bead into the flange, at the same time pressing the fitted part of the bead into the well of the rim. Repeat until the bead is completely over the flange, finishing at the valve position (See Fig. F21).

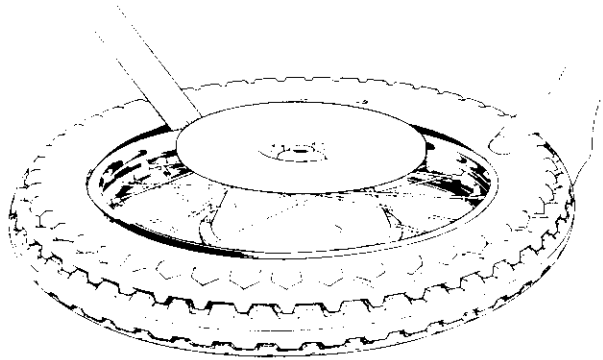


Fig. F21. Refitting the second bead over the wheel rim.
Care must be taken not to trap inner tube.

Push the valve inwards to ensure that the tube near the valve is not trapped under the bead and then pull the valve back firmly into position. **Check that the fitting line on the cover is concentric with the top of the rim flange and that the valve protrudes squarely through the valve hole.** Fit the knurled rim nut and valve cap.

Partially inflate the tire and if necessary, bounce the wheel to help seat the tire, but ensure that there is adequate pressure to prevent damaging the tire or tube. Use moderate force only. If the tire will not seat, it is better to release the pressure, apply soap solution to lubricate and reinflate.

Inflate to the required pressure (see Owners Handbook) and check fitting lines again. Inflation should not be too rapid, particularly at the commencement, to allow the beads to seat correctly on the rim.

Tighten down any security bolts.

Wheels with security bolts

Deflate the tire as already described. Remove the security bolt nuts and push the bolts inside the cover. Remove the first bead as described previously on page F18. Extract the bolts from the rim and then remove the inner tube. Continue operations as for the standard wheel.

To re-fit the tire, replace the first bead as already described **but without the tube inside the cover.** Check that the white spots on the bead are correctly positioned as described earlier in this section and replace the security bolts. Now fit the tube into the cover.

When the second bead is being fitted, push the security bolt(s) well into the cover and make sure that the tube is resting on the flap of the bolt. The remainder of the assembly is as already described. See also Section F24.

SECTION F24

SECURITY BOLTS

If a tire is used in an under-inflated condition it will creep round the rim, taking the tube with it and will ultimately cause the valve to be pulled from the tube.

After removing any burr from the holes, fit the bolts quite loosely and replace the tire so that the covered portion of the security bolt is inside the tire (see Fig. F22).

Check that the tire is correctly positioned, inflate to the required pressure, and tighten the nuts on to the rim.

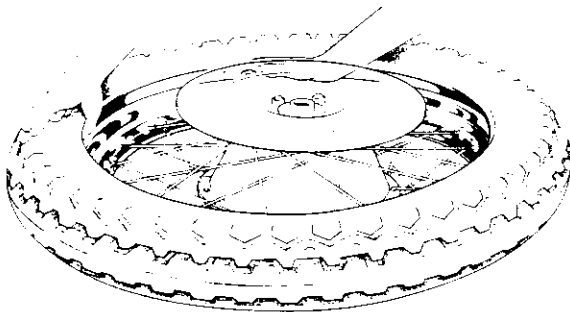


Fig. F22. Placing the security bolt in position.

It is, therefore, usual to fit two security bolts to the rear wheel spaced at 120° each side of the valve.

To fit the bolts, remove the tire and tube, mark the bolt positions and drill the rim between two spoke nipples to the required size of the bolt.

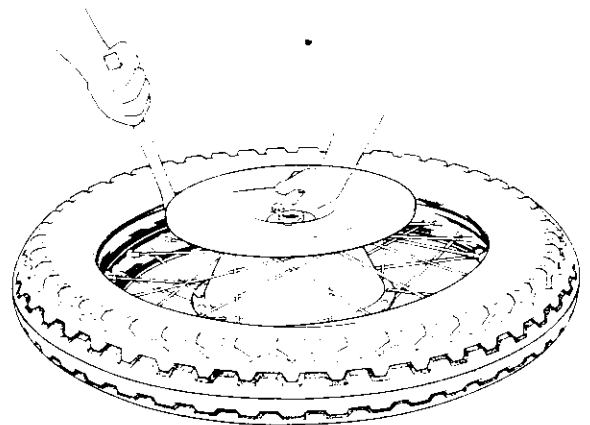


Fig. F23. Refitting the second bead with the security bolt in position.

SECTION F25

TIRE MAINTENANCE

To obtain optimum tire mileage and to eliminate irregular wear on the tires it is essential that the recommendations governing pressures and general maintenance are followed. The following points should be carefully observed.

(1) Maintain the correct inflation pressure as shown in the Owners Handbook. Use a pressure gauge frequently. It is advisable to check and restore tire pressures at least once per week. Pressures should always be checked when tires are cold and not when they have reached normal running temperatures.

(2) Note—Under inflation will not only seriously effect the life of the tire but will also adversely effect the steering.

When a pillion passenger or additional load is carried, the actual load on each tire should be taken and the pressure increased in accordance with the information given in the table. The load on each tire can be found by placing each wheel in turn on a weighbridge with the rider(s) seated on the machine.

(3) Unnecessarily rapid acceleration and fierce braking should always be avoided since this treatment invariably results in rapid tire wear.

(4) Regular checks should be made for flints, nails, small stones etc., which should be removed from the tread or they may ultimately penetrate and damage the casing and puncture the tube.

(5) Tires and spokes should be kept free from oil, grease and kerosene (paraffin). Regular cleaning should be carried out with a cloth and a little gasoline (petrol).

LOAD AND PRESSURE TABLE

(Kg/cm ²) Inflation Pressure (p.s.i.)	1.1	1.4	1.7	2.0	2.25
	16	20	24	28	32
Tire Size	Max load per tire				
Kg 3.50—19 lbs	156	179	197	218	234
	345	395	435	480	515
Kg 4.10—19 lbs	163	186	209	229	250
	360	410	460	505	550

SECTION G

TELESCOPIC FORKS

DESCRIPTION	Section
STEERING HEAD ADJUSTMENT	G1
DISMANTLING AND REASSEMBLING THE FORK LEGS	G2
RENEWING STEERING HEAD BEARINGS	G3
FORK ALIGNMENT	G4
HYDRAULIC DAMPING	G5

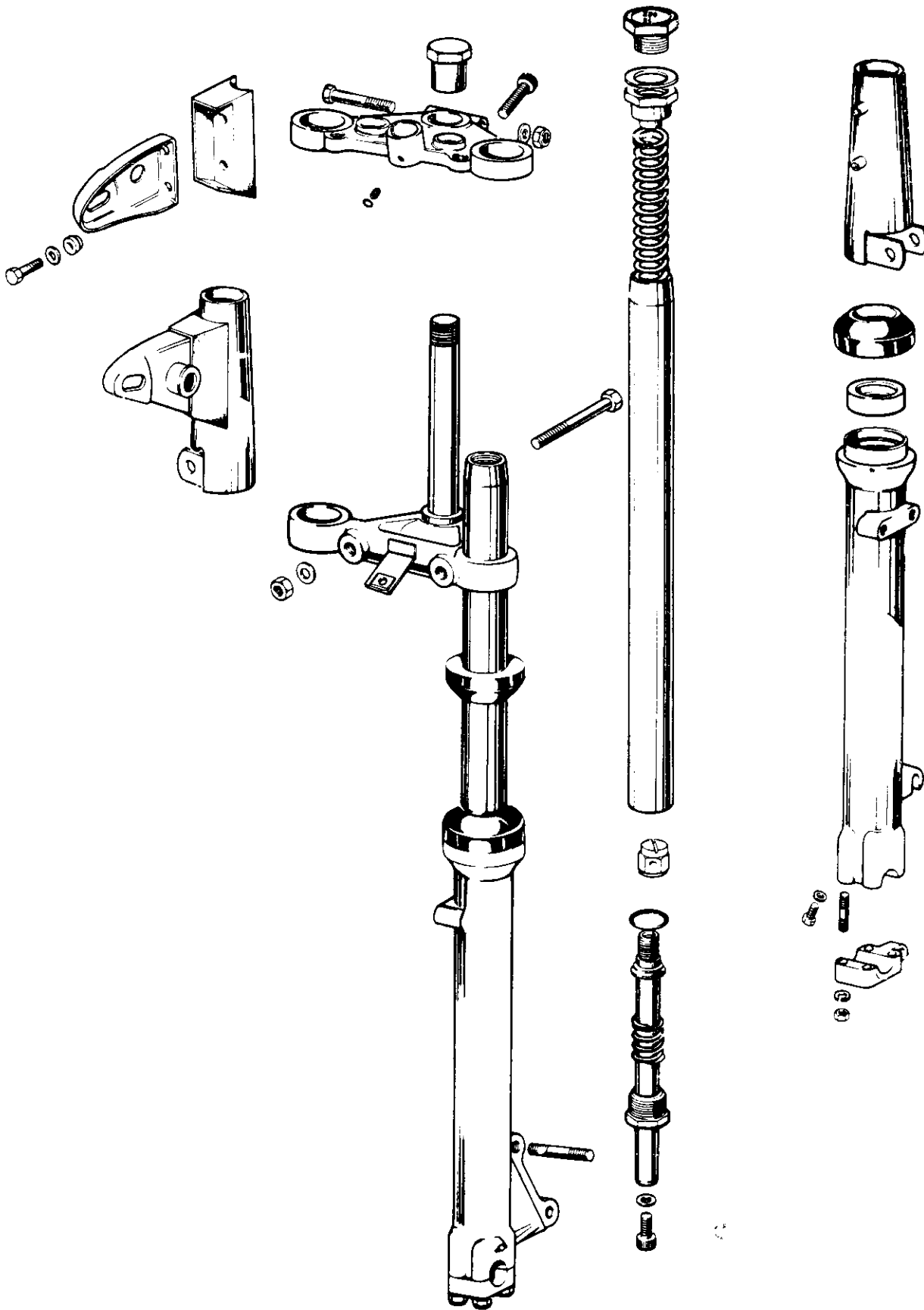


Fig. G1. Fork assembly details

DESCRIPTION

The front fork is of the telescopic type, using high grade steel tube stanchions. They are hard chromium plated, and then ground to an extremely fine surface.

The alloy sliding members are precision bored and provide the bearing for the stanchion. The main springs are enclosed within the stanchion, and locate on the damper tube.

An oil seal is contained in the top lip of each sliding member, and is protected by a rubber dust cover.

Oil is contained in each sliding member, and serves the dual purpose of damping and lubrication. It is added by removal of the stanchion cap nuts, and drained at the plugs provided.

Damping of the telescopic action is achieved by the use of a damper valve in conjunction with a series of bleed holes and slots in the damper tube.

SECTION G1

STEERING HEAD ADJUSTMENT

It is most important that the steering head bearings are always correctly adjusted.

Stand astride the motor cycle and place the finger tips of the left hand on the joint between the steering column and the top bearing cover. Apply the front brake and rock the machine backwards and forwards, when any play will be felt immediately by the left hand.

To adjust the bearings, support the crankcase on a box so that the front wheel is clear of the ground, and slacken the pinch bolt A, (Fig. G2), at the rear of the upper steering yoke. Tighten the adjusting nut B on the steering stem until **only a trace of play is present** on the bearings. The steering must be free and the forks should turn smoothly from lock to lock. If the movement is harsh, the adjustment is tight or the bearings are damaged and must be renewed. When adjustment is correct, tighten the clamp bolt.

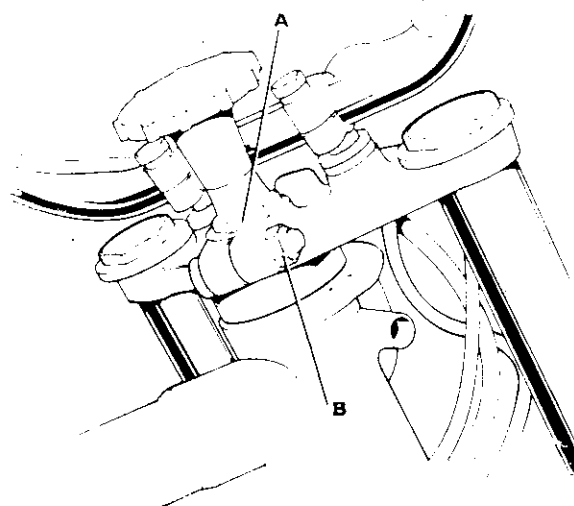


Fig. G2. Steering head adjustment

SECTION G2

DISMANTLING AND REASSEMBLING THE FORK LEGS

Before commencing work on the forks, it is advisable to have the following service tools and replacement parts available.

- (a) Oil seals for dust excluder (2)
- (b) Oil seal for damper valve (2)
- (c) Service tool 61-6113

Unscrew the small drain plugs at the bottom of each fork leg, taking care not to lose the small fibre

seals. Have a receptacle handy to catch the oil. Work the forks up and down a few times, in order to pump the oil out.

Place a strong support under the engine taking care not to damage the exhaust assembly. Remove the front wheel (See Section F15) and the front mudguard. Drain the front brake fluid, as described in Section F6.

Take off the nuts under the top yoke, which secure the handlebar brackets, then lift off the handlebars and lay them on the tank, using a thick piece of cloth or something similar to prevent scratching. Remove the two forward facing bolts which secure the binnacle assembly to the top yoke, and disconnect the drives to the tachometer and speedometer. Slacken the screw on top of the headlamp shell and prise off the rim. Disconnect the green leads from the front flasher lamps, and remove the lamps and stalks (See Section H14). Remove the headlamp and its mounting, and lay it aside, together with the binnacle assembly.

Disconnect the front brake pipe unions and remove the pipes. If it is necessary to remove the brake caliper, see Section F13.

Remove the dust cover from the top of each fork stanchion by unscrewing in an anti-clockwise direction. Unscrew the two socket type clamp bolts, located at the rear of the top fork yoke, and then unscrew the aluminium cap screw from the top of each stanchion using a suitable sized socket wrench. Remove the internal fork springs. Using Service Tool 61-6113 placed down into the stanchion, hold the valve assembly while the retaining socket screw in the base of the fork leg is being unscrewed. The tip of Service Tool 61-6113 is rounded. For

more recent forks, it will be advantageous to grind a flat on the tip, making it screwdriver shaped.

At this stage, it will be possible to remove the fork leg by sliding it from the stanchion. Slacken the pinch bolts on the bottom yoke in order to withdraw the stanchion. When refitting, tighten the pinch bolts to 25 lbs/ft.

The dust cover on the fork leg can easily be prised off by hand. The damper valve is retained in the bottom of the stanchion by an aluminium nut which should be carefully removed with a ring spanner or similar tool. The valve assembly consists of a fixed lead valve with its own seal, a clapper valve, a spring support nut, and a rebound spring. It should not be necessary to strip this assembly unless the fixed bleed is damaged in any way.

The oil seal on the bleed valve can easily be replaced by hand. If using a screwdriver to prise the seal away from the valve, be careful not to damage the bearing surface, as the material is a soft alloy. (Refer to Fig. G3. for details of the assembly). Care should be taken not to lose the sealing washer contained in the bottom of the fork leg. The base of the valve stem rests on the seal, and the socket screw is replaced from the outside of the leg. Refer to the exploded drawing on Page G2 for assembly details.

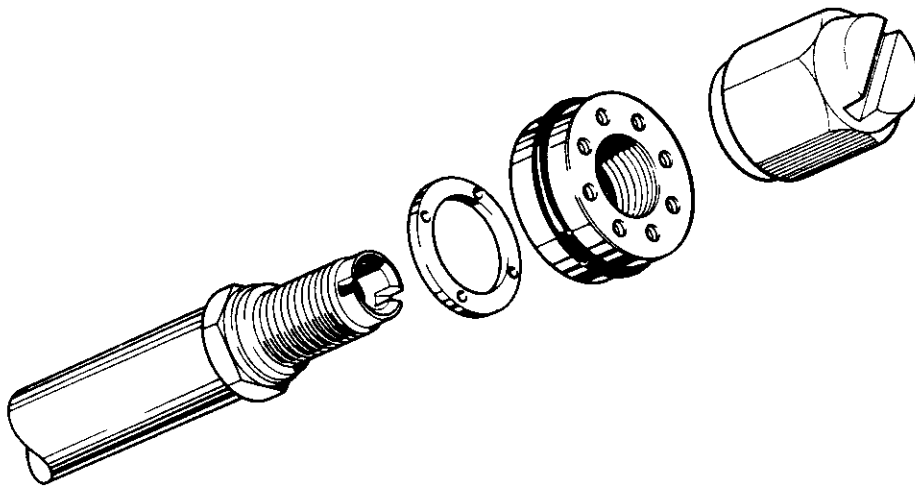


Fig. G3. Assembly of bleed valve

The oil seal contained in the top of the fork leg can be removed with a tool of the design shown in Fig. G4. This tool can be simply manufactured from a strip of mild steel material, approximately 12 inches long by 1 inch wide, and $\frac{3}{16}$ — $\frac{1}{4}$ inch in depth. The design is such that the tool does not come into direct contact with the aluminium fork leg, but every care must be taken to prevent misuse of the tool causing damage to the leg. As an alternative, a long tyre lever, carefully used, will suffice.

Note. When using either of these tools, remove the seal by working around the periphery of the fork leg, otherwise the tool will ruin the lip of the seal. Make sure the housing is clean and free from burrs at the top edge, and insert the new seal into the housing using the following method:-

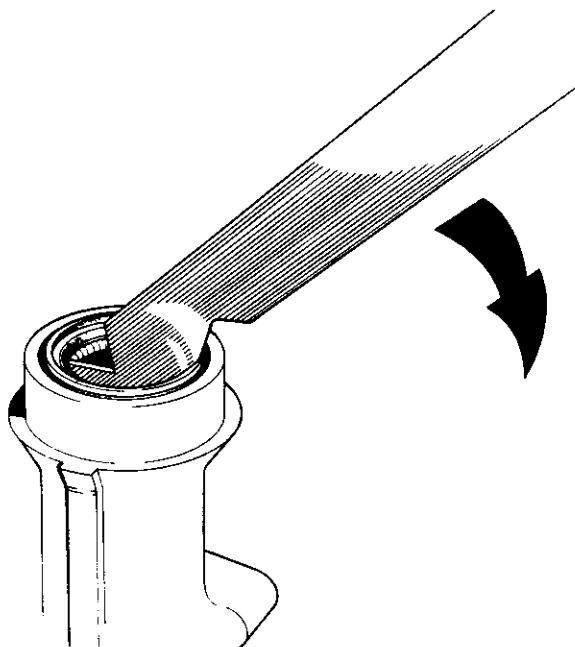


Fig. G4. Removing the oil seal from the fork leg

Reassemble the stanchion into the fork leg, and place a small polythene bag over the lip of the stanchion. Push the oil seal over the stanchion and down into the position on the fork leg. It is important that polythene is used, because the lip of the stanchion has a sharp edge that may easily scratch or damage the precision edge of the seal. Even a scratch which may not be readily visible to the eye will cause leakage at the seal.

A drift will be required to insert the oil seal into the housing. This can be simply fabricated from an early type steel fork outer member. A turned shoulder will have to be machined and brazed or

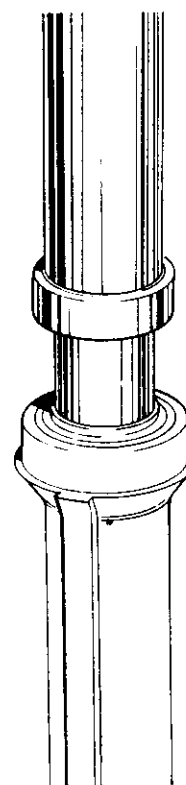


Fig. G5. Replacing the oil seal

welded to one end of the fork leg. See Fig. G5 for details. It is important to assemble the oil seal with the stanchion in position, because the seal must sit squarely in the counter bore, otherwise leakage will occur.

The stanchion can now be removed.

Check all components for cleanliness and wash in gasoline (petrol) if necessary. Examine the bore of the stanchion and clean with a cloth pushed through the bore.

When reassembling the fork leg, replace the valve assembly into the bottom of the stanchion. Apply a little Loctite to the aluminium retaining nut, and tighten to a torque of 25 ft/lbs.

Check that the small special sealing washer is located in the well in the base of the fork leg. (If this washer shows signs of damage or wear, it must be replaced).

Push the rubber dust cover onto its location groove on the fork leg and then replace the leg of the stanchion.

As the leg is refitted onto the stanchion the stem of the damper valve assembly must be located on the

top of the sealing washer. If difficulty is encountered during this operation, Service tool 61-6113, which is used to retain the valve assembly while it is being removed, may be used to guide the damper valve onto its location.

The socket screw can then be replaced into the bottom of the fork leg and tightened as described above.

Replace the fork springs, and refill the fork legs with the correct quantity of oil. Replace the fork

cap nuts, tightening them to a torque setting of 45-50 ft/lbs. The brake pipes etc. can then be refitted, as can the binnacle assembly and the electrics. The handlebar, front mudguard, and front wheel can then be replaced.

Finally, refill the brake system with the appropriate amount of hydraulic fluid. It will, of course, be necessary to "bleed" the brake before using the machine again.

SECTION G3

RENEWING HEAD BEARINGS

The steering head bearings are of taper roller type, and are thus capable of satisfactory service over a lengthy mileage before replacement should become necessary, always providing that the bearings are kept in correct adjustment, and that lubrication is adequate.

In order to obtain access to these bearings, proceed as in Section G2 to the point where the fork stanchions have been removed from the top and bottom yokes. Next, slacken the pinch bolt 'B' (Fig. G2), and remove the adjuster nut 'A'. Using a hide mallet, tap upwards on the underside of the top yoke, tapping either side of the yoke alternately until it is free.

The bottom yoke, complete with steering stem, can then be withdrawn downwards. The taper roller bearings should be removed, for cleaning

and inspection. Check for pitting and fracture of the roller surface. The bearing must be replaced if any of these faults are in evidence.

The steering head outer races have a very long serviceable life, as mentioned previously, but if their replacement is deemed necessary the races can be removed using a suitable drift from inside the steering head lug of the frame.

Reassembly is basically the reverse of the dismantling procedure, but great care should be taken to ensure that the steering head outer races are replaced squarely in the head lug, a substantial drift being used for this purpose such as Service tool 61-6121.

The steering head bearings should be greased on replacement, after which, they should be adjusted as described in Section G1.

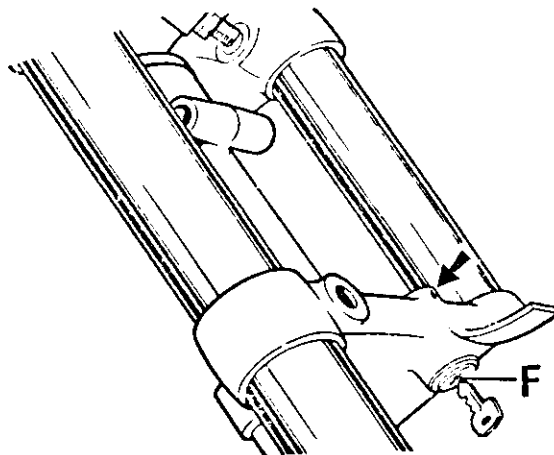


Fig. G6. Fork Steering Lock in the Fork Bottom Yoke.

SECTION G4

FORK ALIGNMENT

After replacing the fork legs, mudguard, and wheel, it may be found that the legs are incorrectly aligned.

To rectify this, the wheel spindle cap nuts must first be screwed up tight on the right side leg and the spindle cap nuts on the left side leg slackened off. Also loosen the stanchion top caps and the pinch bolts in both the bottom and top yokes. The forks should now be worked up and down several times to line them up, and the various connections tightened from bottom to top, that is, wheel spindle, bottom yoke pinch bolts, top caps and finally, the steering stem pinch bolt in the top yoke.

If, after this treatment, the forks still do not function satisfactorily then either the fork stanchions are bent or one of the yokes is twisted.

The stanchions can only be accurately checked for straightness with special equipment such as a surface plate. Special gauges are also required to check the yokes. It is possible, however, to make a reasonable check of the stanchions by rolling them on a surface plate or flat surface such as a piece of plate glass, but it is not a simple operation to straighten a bent tube, and a new part may be necessary.

Check the stanchions for truth by rolling them slowly on a flat checking table. A bent stanchion may be realigned if the "bow" does not exceed $\frac{5}{32}$ in. To realine the stanchion, a hand press is required. Place the stanchion on two "V" blocks, one at either end, and apply pressure to the

raised portion of the stanchion. By means of alternately pressing in this way, and checking the stanchion on a flat table, the amount of bow can be reduced until it is finally removed.

Having checked the stanchions for straightness, and reset as necessary, the top and bottom yokes can now be checked. First, assemble the two stanchions into the bottom yoke, so that a straight edge across the lower ends is touching all four edges of the tubes, then tighten the pinch bolts. Now examine them from the side when the two stanchions should be quite parallel. Alternatively, the lower 12 in. of the stanchions can be placed on a surface plate, when there should be no rocking.

To reset, hold one stanchion in a vice (using soft clamps) and reset the other stanchion, using a longer and larger diameter tube so to obtain sufficient leverage. Having checked the stanchions in this way, check the gap between them.

The next step is to place the bottom yoke in position over the stanchions, and tighten the clip bolts, when the steering stem should be centrally disposed between the two stanchions.

The final step is to check if the tubes are parallel when assembled into the top yoke only. In this case the bottom yoke can be fitted loosely on the tubes, as a pilot only.

Though it is permissible to rectify slight errors in alignment by resetting, it is much safer to replace the part affected especially when there is excessive misalignment.

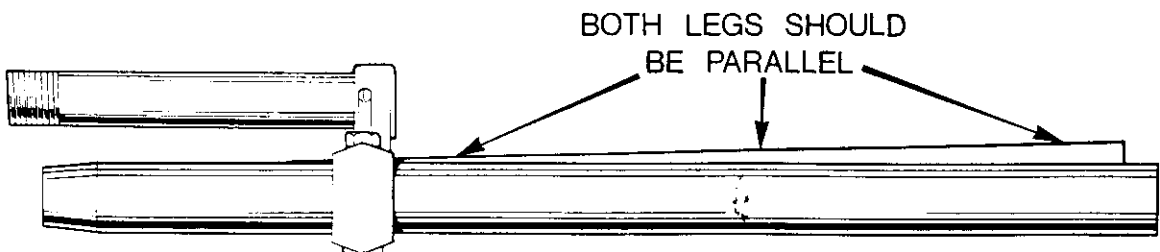


Fig. G7. Fork leg alignment

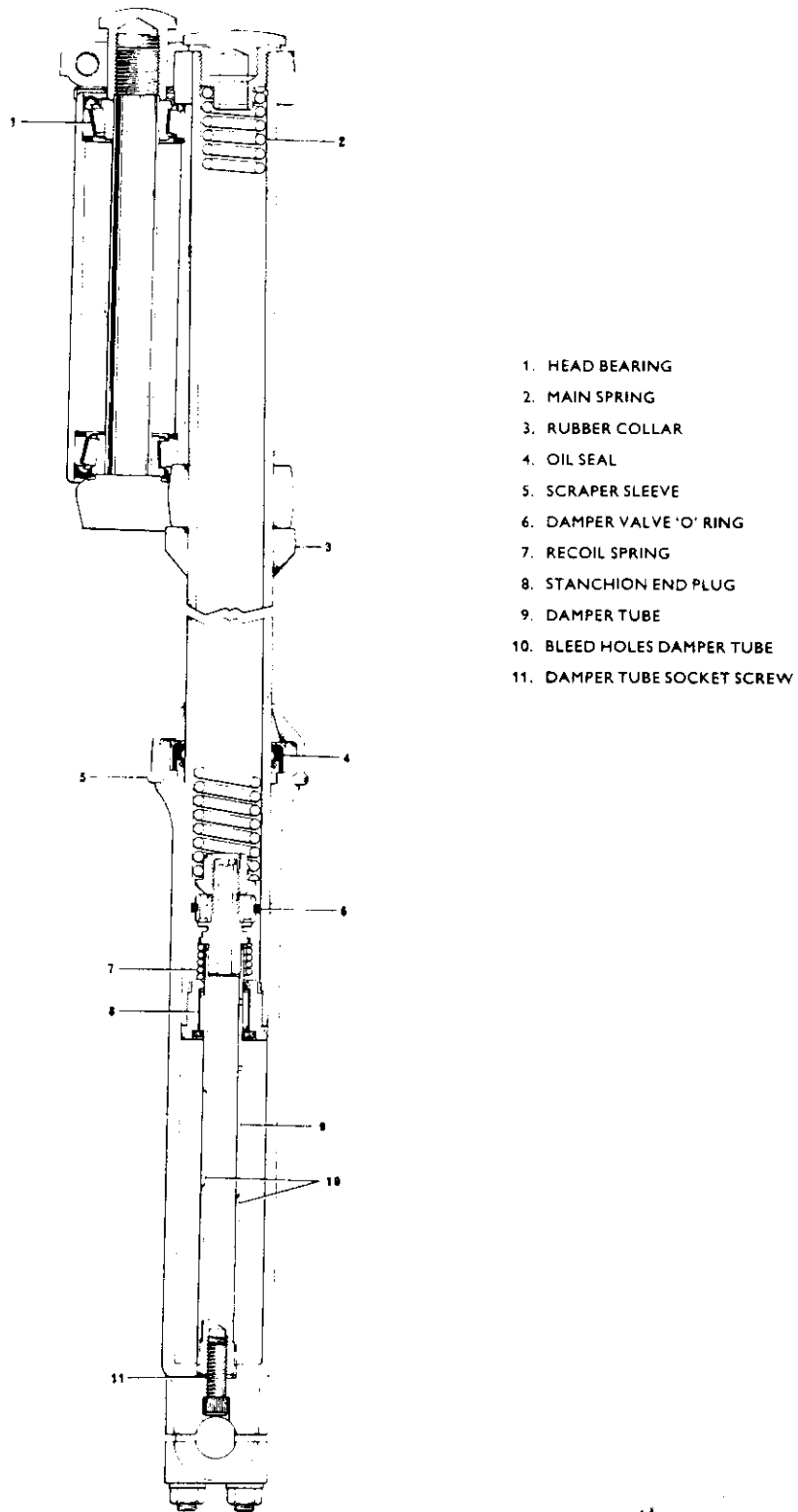


Fig. G8. Sectional view of assembled fork leg

SECTION G5

HYDRAULIC DAMPING

Note the valve assembly which is retained in the bottom of the fork leg. Bleed holes are contained in the valve stem, and in a sub-assembly at the top of the stem. This sub-assembly incorporates a damper valve, which acts as a restrictor.

Oil is contained in the fork sliding member, the level of which is always above the valve assembly. On compression of the fork the oil is forced through bleed holes or slots in the damper tube. As the travel increases the bleed apertures are progressively sealed off by a plastic sleeve, and the damping increases until the stanchion is trapped on a cushion of oil, which acts as the final bump stop. During this

operation, a vacuum is created in the space formed between the bottom of the stanchion and the damper valve. Oil is transferred into this compartment through the bleed holes in the damper tube.

On expansion of the forks, the oil in this newly formed compartment is compressed, the damper valve closes, and the oil is bled through small holes in the damper valve itself, and then progressively through the apertures in the damper tube. During this operation oil is transferred back in to the bottom member, in readiness for the next compression of the forks.

SECTION H

ELECTRICAL SYSTEM

INTRODUCTION	
BATTERY INSPECTION AND MAINTENANCE	
DESCRIPTION	H1
(a) ROUTINE MAINTENANCE	
(b) MAXIMUM PERMISSIBLE ELECTROLYTE TEMPERATURES DURING CHARGING	
CONDENSOR PACK	H2
COIL IGNITION SYSTEM	H3
DESCRIPTION	
(a) CHECKING THE LOW TENSION CIRCUIT FOR CONTINUITY	
(b) FAULT FINDING IN THE LOW TENSION CIRCUIT	
(c) IGNITION COILS	
(d) CONTACT BREAKER	
(e) CHECKING THE HIGH TENSION CIRCUIT	
SPARKING PLUGS	H4
CHARGING SYSTEM	H5
DESCRIPTION	
(a) CHECKING THE D.C. OUTPUT AT THE RECTIFIER	
(b) CHECKING THE ALTERNATOR OUTPUT	
(c) RECTIFIER MAINTENANCE AND TESTING	
(d) CHECKING THE CHARGING CIRCUIT FOR CONTINUITY	
(e) MAKING A 1 OHM LOAD RESISTOR	
ZENER DIODE CHARGE CONTROL AND TEST PROCEDURE	H6
ZENER DIODE LOCATION	H7
ELECTRIC HORN	H8
HEADLAMP	H9
DESCRIPTION	
BEAM ADJUSTMENTS	
HEADLAMP REMOVING AND REFITTING	H10
TAIL AND STOP LAMP UNIT	H11
FUSES	H12
IGNITION SWITCH	H13
FLASHER LAMPS	H14
WARNING LAMPS	H15
STOP LAMP SWITCHES	H16
OIL PRESSURE SWITCH	H17
CAPACITOR IGNITION (Model 2MC)	H18
IDENTIFICATION OF CAPACITOR TERMINALS	
TESTING	
WIRING AND INSTALLATION	
SERVICE NOTES	
THE STARTER MOTOR CIRCUIT	H19
WIRING DIAGRAM	H20

INTRODUCTION

The electrical system is supplied from an alternating current generator contained in the timing cover and driven from the crankshaft. The generator output is then converted into direct current by a silicon diode bridge connected rectifier. The direct current is supplied to a 12 volt 8 ampere/hour battery with a Zener Diode in circuit to regulate the battery current.

The current is then supplied to the ignition system which is controlled by a triple contact breaker driven direct from the exhaust camshaft. The contact breaker feeds three ignition coils, one for each cylinder, and the three capacitors are mounted separately in a water-

proof pack. The battery supplies current for the headlamp, tail lamp and instruments and warning light in the binnacle. A 12 volt type 6H horn is fitted.

The routine maintenance needed by the various components is set out in the following sections. All electrical components and connections including the earthing points to the frame of the machine must be clean and tight.

No emergency start facility is provided. On these models there is, however, sufficient voltage to start the machine when a discharged battery is in circuit.

SECTION H1

BATTERY INSPECTION AND MAINTENANCE

The battery containers are moulded in translucent polystyrene through which the acid level can be seen. The battery top is so designed that when the cover is in position, the special anti-spill filler plugs are sealed in a common venting chamber. Gas from the filler plugs leaves this chamber through a vent pipe union at the side of the top. The vent at the other side of the top is sealed off. Polythene tubing is attached to the vent pipe union to lead corrosive fumes away from parts of the machine which may otherwise suffer damage. To prepare a dry-charged battery for service, first discard the vent hole sealing tape and then pour into each cell pure dilute sulphuric acid of appropriate specific gravity to THE MAXIMUM LINE. (See table in Part A). Allow the battery to stand for at least one hour for the electrolyte to settle down, thereafter maintain the acid level at the line by adding distilled water. The battery should then receive an initial charge of 1 Ampere for approximately 3 hours prior to fitting to the machine

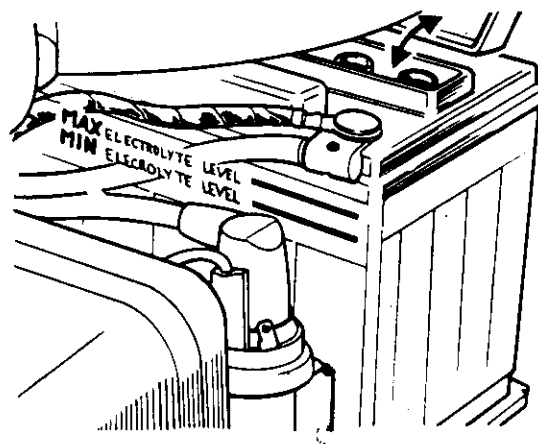


Fig. H1. The Battery

H1. PART A. ROUTINE MAINTENANCE

Every week examine the level of the electrolyte in each cell. Lift the battery out of the carrier so that the filling line can be seen. Add distilled water until the electrolyte level reaches this line.

Note.- On no account should the battery be topped up to the separator guard but only to the maximum line.

With this type of battery, the acid can only be reached by a miniature hydrometer, which would indicate the state of the charge.

Great care should be taken when carrying out these operations not to spill any acid or allow a naked flame near the electrolyte. The mixture of oxygen and hydrogen given off by a battery on charge, and to a lesser extent when standing idle, can be dangerously explosive.

The readings obtained from the battery electrolyte should be compared with those given in the table below. If a battery is suspected to be faulty it is advisable to have it checked by a Lucas Service Centre or Agent.

SPECIFIC GRAVITY OR ELECTROLYTE FOR FILLING THE BATTERY

U.K. and Climates normally below 90°F (32.2°C)		Tropical Climates over 90°F (32.2°C)	
Filling	Fully charged	Filling	Fully charged
1.260	1.280/1.300	1.210	1.220/1.240

Every 1,000 miles (1,500 km.) or monthly, or more regularly in hot climates the battery should be cleaned as follows. Remove the battery cover and clean the battery top. Examine the terminals: if they are corroded scrape them clean and smear them with a film of petroleum jelly, such as vaseline.

Remove the vent plugs and check that the vent holes are clear.

H.1 PART B. MAXIMUM PERMISSABLE ELECTROLYTE TEMPERATURE DURING CHARGE

Climates normally Below 80°F (27°C)	Climates between 80-100°F (27-38°C)	Climates frequently above 100°F (38°C)
100°F (38°C)	110°F (43°C)	120°F (49°C)

Notes

The specific gravity of the electrolyte varies with the temperature. For convenience in comparing specific gravities, they are always corrected to 60°F., which is adopted as a reference temperature. The method of correction is as follows.

For every 5°F. below 60°F. deduct .020 from the observed reading to obtain the true specific gravity at 60°F. For every 5°F. above 60°F., add .020 to the observed reading to obtain the true specific gravity at 60°F.

The temperature must be indicated by a thermometer having its bulb actually immersed in the electrolyte and not the ambient temperature. To take a temperature reading tilt the battery side-ways and then insert into the electrolyte.

SECTION H2

CONDENSER PACK

The condensers are located on a mounting plate beneath the twinseat, being protected from water by a rubber cover ("B" Fig. H2). Each condenser is connected into the low tension circuit by means of a "Lucar" connector.

To remove any one of the condensers, disconnect the low tension lead, remove the rubber cover, remove the nut and shakeproof washer and withdraw the capacitor.

Reassembly is undertaken in the reverse order.

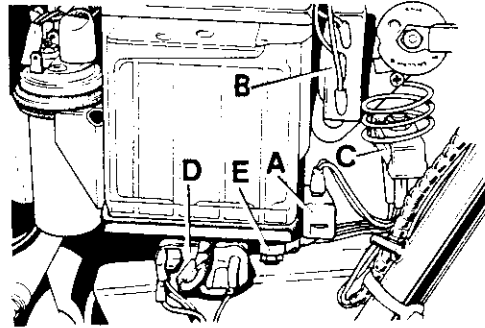


Fig. H2. The Electrical Units

- A BALLAST RESISTOR UNIT
- B CONDENSER PACK
- C DIRECTION INDICATOR FLASHER UNIT
- D STARTER RELAY UNIT
- E 'HEADLIGHT-ON' WARNING UNIT (where fitted)

SECTION H3

COIL IGNITION SYSTEM

The coil ignition system comprises a 7CA contact breaker in the timing cover driven by the exhaust camshaft feeding three ignition coils fitted, with vibration proof rubber rings, into the mounting plate beneath the hinged twinseat.

Attention to the contact breaker is covered by Section H3 part D. The ignition coils can be removed for testing, as in Section H3 part C, merely by disconnecting the terminals, grasping each coil in turn, and lifting it firmly away from rubber mounting ring.

The condenser pack is secured to the plate by two small screws and nuts, and after removal and disconnecting of the spade terminals the rubber cover can be pulled away, leaving only the condensers each of which is secured by a

serrated washer and nut. The coils and condensers require no attention beyond keeping them clean and the terminals sound.

The best method of approach to a faulty ignition system is that of first checking the low tension circuit for continuity as shown in H3 Part A, and then following the procedure laid out in H3 Part B to locate the fault(s).

Failure to locate a fault in the low tension circuit indicates that the high tension circuit or sparking plugs are faulty and the procedure detailed in H3 Part E must be followed. Before commencing any of the following tests, however, the contact breaker and sparking plugs must be cleaned and adjusted to eliminate these possible sources of faults.

H3 PART A. CHECKING THE LOW TENSION CIRCUIT FOR CONTINUITY

To check whether there is a fault in the low tension circuit and to locate its position, the following tests should be carried out:-

First inspect the in-line fuse in the battery earth cable (brown/blue lead) and replace if suspect.

Check also the cut-out switch; this can be done by disconnecting the white, and white/yellow lead from the right handlebar switch and connecting them together. This will complete the ignition circuit by by-passing the cut-out switch.

H3 PART B. FAULT FINDING IN THE LOW TENSION CIRCUIT

To trace a fault in the low tension wiring, turn the ignition switch on and then place a piece of insulating material between all sets of contacts whilst the following test is carried out.

Note. Disconnect the Zener Diode before the test is carried out. To do this remove the brown/blue lead from the Diode centre terminal.

For this test, it is assumed that the twinseat is lifted and the wiring is fully connected as shown in the wiring diagram, Section H20. With the aid of a 0-15 range D.C. voltmeter and 2 test-prods, make a point to point check along the low tension circuit starting at the battery and working right through to the ignition coils, stage by stage, in the following manner, referring to the wiring diagram in Section H20.

- (1) First, establish that the battery is earthed correctly by connecting the volt meter across the battery negative terminal and the machine frame earth. No voltage reading indicates that the red earthing lead is faulty. Check the fuse in the main negative lead. Also, a low reading would indicate a poor battery earth connection, or a discharged battery.
- (2) Connect the voltmeter in turn between each ignition coil (-Ve) terminal and earth on all three coils. No voltage reading indicates a breakdown between the

battery and the coil (-Ve) terminal, or that the switch connections are faulty.

- (3) Connect the voltmeter between ignition switch input terminal and earth. No reading indicates that the brown and blue lead has faulty connections. Check for voltage at the brown/blue lead connections at rectifier.
- (4) Connect the voltmeter across ignition switch output terminal (2) and earth. No reading indicates that the ignition switch is faulty and should be replaced. Battery voltage reading at this point but not at the ignition coil (-Ve) terminals indicates that the ballast resistor has become "open circuit" or become disconnected. Remember that the ballast resistor is by-passed, and the ignition coils fed directly from the battery via the Starter relay, when the starter button is depressed.
- (5) Connect the voltmeter across the (+Ve) terminal of each coil and earth in turn. No reading on the voltmeter between any one coil and earth indicates that the coil primary winding is faulty and a replacement ignition coil should be fitted.
- (6) With insulating material still retained between the three sets of contacts, connect the voltmeter across each set of contacts in turn. No reading between any one set of contacts and earth indicates that there is a faulty connection or the internal insulation has broken down in one of the condensers.

If a condenser is suspected then a substitution should be made and a re-test carried out.

- (7) Finally, reconnect the Zener Diode brown/white lead and then connect the volt meter between the Zener Diode centre terminal and earth. The volt meter should read battery volts. If it does not the Zener Diode is faulty and a substitution should be made. Refer to Section H6 (page H13) for the correct procedure for testing a Zener Diode on the machine. Ignition coil check procedure is given in Section H3 part C.

H3 PART C. IGNITION COILS (6 volt)

The ignition coils consist of primary and secondary windings wound concentrically about a laminated soft iron core, the secondary windings being next to the core. The primary winding consists of 280-372 turns of enamel covered wire and the secondary, some 19,000 turns of much finer wire, also enamel covered. Each layer is paper insulated from the next in both primary and secondary windings.

To test the ignition coils on the machine, first ensure that the low tension circuit is in order as described in H3 Part A then disconnect the high tension leads from each of the sparking plugs. Turn the ignition switch on and crank the engine until the contacts (those with the black/white lead from the ignition coil) for the right (No.1) cylinder are closed having removed the insulation from between the contacts. Flick the contact breaker lever open a number of times whilst the high tension lead from the ignition coil with the black and white lead is held about $\frac{3}{16}$ in. away from the cylinder head. If the ignition coil is in good condition a strong spark should be obtained. If no spark occurs this indicates the ignition coil to be faulty.

Repeat this test in turn for each of the other coils ensuring that the contacts for the coil being tested are closed. The lead colours at the coils are of course the same at the contacts.

Before a fault can be attributed to an ignition coil it must be ascertained that the high tension cables are not cracked or showing signs of deterioration, as this may often be the cause of mis-firing etc. It should also be checked that the ignition points are actually making good electrical contact when closed and that the moving contact is insulated from earth (ground) when open. (See Test H3 Part B). It is advisable to remove the ignition coils and test them by the method described below.

BENCH TESTING THE IGNITION COIL

Connect the ignition coil into the circuit shown in Fig. H3 and set the adjustable gap to 8 mm.

Using a single lobe contact breaker running at 600 r.p.m. and the coil in good condition, not more than 5% missing should occur at the spark gap over a period of 15 seconds. The primary winding can be checked for short-circuit coils by connecting an ohmmeter across the low tension terminals. The reading obtained for the 17M6 coil at 20°C should be within 1.7 ohms minimum and 1.9 ohms maximum.

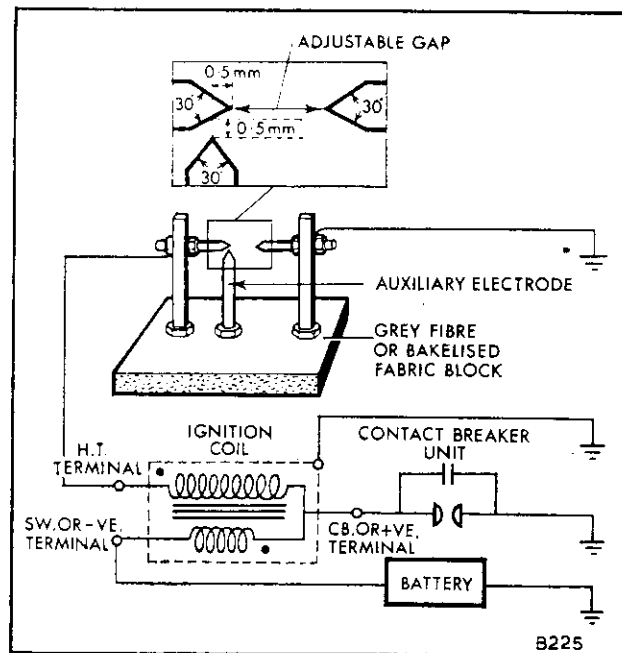


Fig. H3. Ignition coil test rig

H3 PART D. CONTACT BREAKER

Faults occurring at the contact breaker are in the main due to, incorrect adjustment of the contacts or the efficiency being impaired by piling, pitting or oxidation of the contacts due to oil etc. Therefore, always ensure that the points are clean and that the gap is adjusted to the correct working clearance as described in Section B25.

To test for a faulty condenser, first turn the ignition switch on and then take voltage readings across each set of contacts in turn with the contacts open. No reading indicates that the condenser internal insulation has broken down. Should the fault be due to a condenser having a reduction in capacity, indicated by excessive arcing when in use, and overheating of the contact faces, a check should be made by substitution.

Particular attention is called to the periodic lubrication procedure for the contact breaker which is given in Section A11. When lubricating the parts ensure that no oil or grease gets onto the contacts.

If it is felt the contacts require surface grinding then the complete contact breaker unit should be removed as described in Section B24 and the moving contacts removed by unscrewing the nut which secures the low tension lead, removing the lead and nylon bush. The spring and contact point can be removed from the pivot spondle. Repeat this procedure for the other contact points.

Grinding is best achieved by using a fine carborundum stone or very fine emery cloth, afterwards wiping away any trace of dirt or metal dust with a clean petrol (gasoline) moistened cloth. The contact faces should be slightly domed to ensure point contact. There is no need to remove the pitting from the fixed contact.

When reassembling, the nylon bush is fitted

through the low tension connection tab, and through the spring location eye. Apply a smear of grease to the C.B. cam and moving contact pivot post. Every 3,000 miles and/or contact replacement, apply two drops of clean engine oil to the rear of the three lubricating felt wicks.

H3 PART E. CHECKING THE HIGH TENSION CIRCUIT

If ignition failure or mis-firing occurs, and the fault is not in the low tension circuit, then check the ignition coils as described in Part C. If the coils prove satisfactory, ensure that the high tension cables are not the cause of the fault.

If a good spark is available at the high tension cable, then the sparking plug suppressor cap or the sparking plug itself may be the cause of the fault. Clean the sparking plug and adjust the electrodes to the required setting as described in Section H4 and then re-test the engine for running performance. If the fault recurs then it is likely the suppressor caps are faulty and these should be renewed.

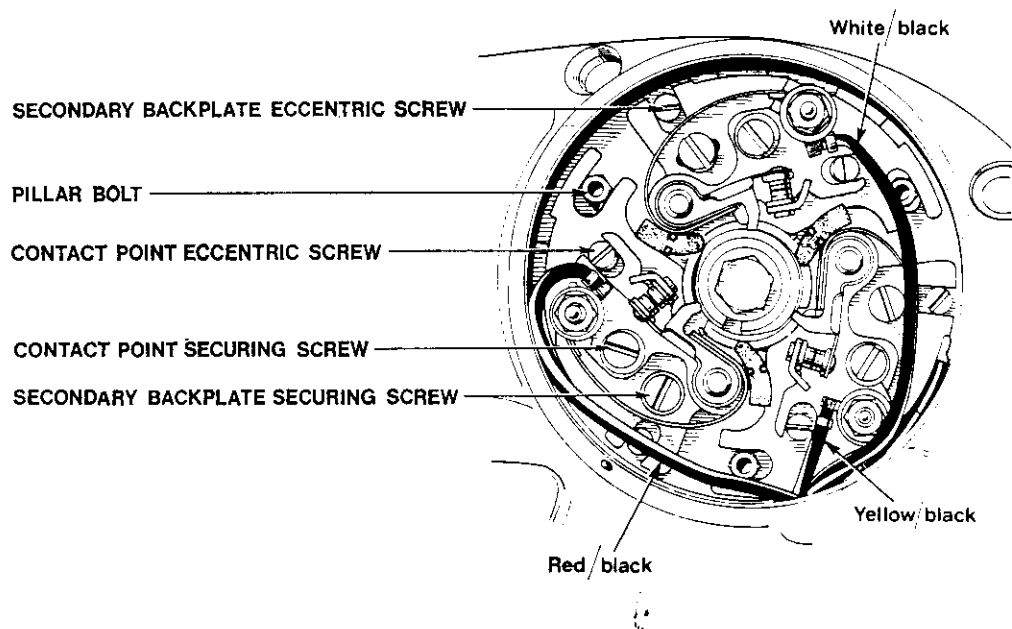


Fig. H4. Contact breaker assembly type 7CA

SECTION H4

SPARKING PLUGS

It is recommended that the sparking plugs be inspected, cleaned and tested every 3,000 miles (4,800 km.) and new ones fitted every 12,000 miles (20,000 km.).

To remove the sparking plugs, a box spanner ($\frac{13}{16}$ in. (19.5 mm.) across flats) should be used, and if any difficulty is encountered, a small amount of penetrating oil (see lubrication chart Section A2) should be placed at the base of the sparking plug and time allowed for penetration. When removing the sparking plugs identify each plug with the cylinder from which it was removed so that any faults revealed on examination can be traced back to the cylinder concerned.

Examine all plugs for signs of oil fouling. This will be indicated by a wet, shiny, black deposit on the central insulator. This is caused by excessive oil in the combustion chamber during combustion and indicates that the piston rings or cylinder bores are worn.

Next examine the plugs for signs of petrol (gasoline) fouling. This is indicated by a dry, sooty, black deposit which is usually caused by over-rich carburation, although ignition system defects such as a discharged battery, faulty contact breaker, coil or capacitor defects, or a broken or worn out cable may be additional causes. To rectify this type of fault the above mentioned items should be checked with special attention given to carburation system.

Over-heating of the sparking plug electrodes is indicated by severely eroded electrodes and a white burned or blistered insulator. This type of fault is usually caused by weak carburation, although plugs which have been operating whilst not being screwed down sufficiently can easily become over-heated due to heat that is normally dissipated through to the cylinder head not having an adequate conducting path. Over-heating is normally symptomised by pre-ignition, short plug life, and "pinking" which can ultimately result in piston crown failure. Unnecessary damage

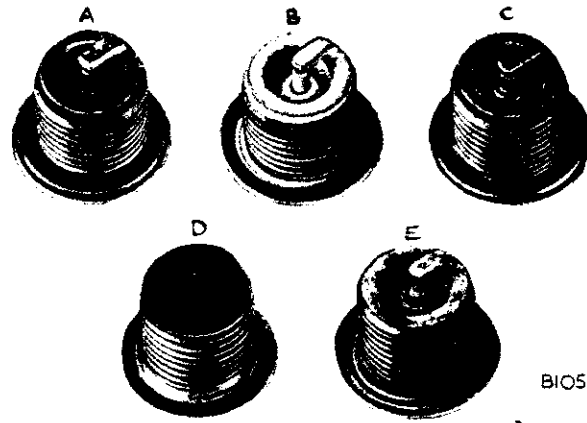


Fig. H5. Sparking plug diagnosis

can result from over-tightening the plugs and to achieve a good seal between the plug and cylinder head a torque wrench should be used to tighten the plugs to the figure quoted in "General Data".

A plug of the correct grade will bear a light flaky deposit on the outer rim and earth electrode, and these and the base of the insulator will be light chocolate brown in colour. A correct choice of plug is marked A. B shows a plug which appears bleached, with a deposit like cigarette ash; this is too 'hot-running' for the performance of the engine and a cooler-running type should be substituted. A plug which has been running too 'cold' and has not reached the self-cleaning temperature is shown at C. This has oil on the base of the insulator and electrodes, and should be replaced by a plug that will burn off deposits and remove the possibility of a short-circuit. The plug marked D is heavily sooted, indicating that the mixture has been too rich, and a further carburation check should be made. At illustration E is seen a plug which is completely worn out and badly in need of replacement.

To clean the plugs it is preferable to make use of a properly designed proprietary plug cleaner. The maker's instructions for using the cleaner should be followed carefully.

When the plugs have been carefully cleaned, examine the central insulators for cracking and the centre electrode for excessive wear. In such cases the plugs have completed their useful life and new ones should be fitted.

Finally, before re-fitting the sparking plugs the electrodes should be adjusted to the correct gap setting of .020 in. (.5mm.). Before refitting sparking plugs the threads should be cleaned by means of a wire brush and a minute amount of graphite grease smeared onto the threads. This will prevent any possibility of threads seizure occurring.

If the ignition timing and carburation settings are correct and the plugs have been correctly fitted, but over-heating still occurs then it is possible that carburation is being adversely affected by an air leak between the

carburettor, manifold and the cylinder head. This possibility must be checked thoroughly before taking any further action. When it is certain that none of the above mentioned faults are the cause of over-heating then the plug type and grade should be considered.

Normally the type of plugs quoted in "General Data" are satisfactory for general use of the machine but in special isolated cases, conditions may demand a plug of a different heat range. Advice is readily available to solve these problems from the plug manufacturer who should be consulted.

Note— if the air filter has been removed it will affect the carburation of the machine and hence may adversely affect the grade of sparking plugs fitted.

SECTION H5

CHARGING SYSTEM

DESCRIPTION

The charging current is supplied by the two lead alternator, but due to the characteristics of alternating current the battery cannot be charged direct from the alternator. To convert the alternating current to direct current a full wave bridge silicon type rectifier is connected into the circuit. The alternator gives full output, all the alternator coils being permanently connected across the rectifier.

Excessive charge is absorbed by the Zener Diode which is connected across the battery.

Always ensure that the ignition switch is in the "OFF" position whilst the machine is not in use, to prevent overheating of the ignition coils, and discharging the battery.

To locate a fault in the charging circuit, first test the alternator as described in H5 Part B. If the alternator is satisfactory, the fault must lie in the charging circuit, hence the rectifier must be checked as given in Section H5 Part C (page H10) and then the wiring and connections as shown in Section H5 Part D (page H12).

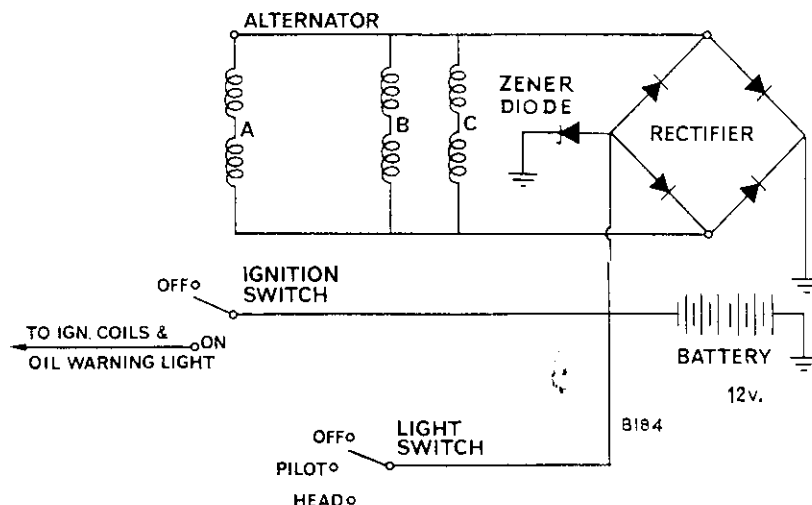


Fig. H6. Schematic diagram of 12 volt charging circuit with Zener Diode

H5 PART A. CHECKING THE D.C. OUTPUT AT THE RECTIFIER

For this test the battery must be in good condition and a good state of charge, therefore before conducting the test ensure that the battery is up to the required standard, or alternatively fit a good replacement battery. Disconnect the brown/blue centre lead at the rectifier, connect a D.C. ammeter (0-15 AMP.) in series between the centre terminal and the main brown/blue lead, start the engine and run at approximately 3,000 r.p.m. (equivalent to 45 m.p.h. in top gear).

Note.—Ensure that the ammeter is well-insulated from the surrounding earth points otherwise a short circuit may occur.

A single charge rate is used and irrespective of switch positions the minimum D.C. output from the rectifier at 3,000 r.p.m. should be no less than 9.5 amperes.

H5 PART B. CHECKING THE ALTERNATOR OUTPUT

Disconnect the two alternator output cables underneath the engine and run the engine at 3,000 r.p.m. (equivalent to 45 m.p.h. in top gear).

Connect an A.C. voltmeter (0-15 volts) with 1 ohm load resistor in parallel to the alternator leads. Observe the voltmeter readings which should be 9V. minimum. A suitable 1 ohm load resistor can be made from a piece of nichrome wire as shown in Section H5 Part E.

If the reading is low, check the rotor by substitution. A zero reading indicates open-circuited coil(s). A reading between any of the two leads and the stator laminations indicates earthed coil(s).

Always check the stator leads for possible chain damage before attempting repairs or renewing the stator.

H5 PART C. RECTIFIER MAINTENANCE AND TESTING

The silicon bridge rectifier requires no maintenance beyond checking that the connections are clean and tight, and that the nut securing the rectifier to the frame is tight. It should always be kept clean and dry to ensure good cooling, and spilt oil washed off immediately with hot water.

Note.—The nuts clamping the rectifier plates together must not be disturbed or slackened in any way. **NEVER** disturb the nut "A", shown in Fig. H7.

When tightening the rectifier securing nut, hold the spanners as shown in Fig. H7, for if the plates are twisted, the internal connections will be broken.

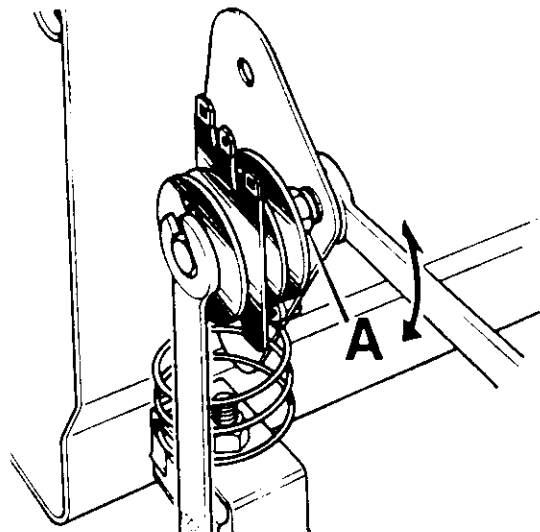


Fig. H7. Refitting the rectifier

TESTING THE RECTIFIER

For test purposes disregard the end earth (ground) terminal on later rectifiers.

To test the rectifier, first disconnect the brown/blue lead from the rectifier centre terminal and insulate the end of the lead to prevent any possibility of a short circuit occurring, and then connect a D.C. voltmeter (with 1 ohm load resistor in parallel) between the rectifier centre terminal and earth.

Note.—Voltmeter positive terminal to frame earth (ground) and negative terminal to centre terminal on rectifier.

With the engine running at approximately 3,000 r.p.m. (approximately 45 m.p.h. in top gear) observe the voltmeter reading. The reading obtained should be at least 7.5V minimum.

- (i) If the reading is equal to or slightly greater than that quoted, then the rectifier elements in the forward direction are satisfactory.
- (ii) If the reading is excessively higher than the figures given, then check the rectifier earthing bolt connection.
- (iii) If the reading is lower than the figures quoted or zero readings are obtained, then the rectifier or the charging circuit wiring is faulty and the rectifier should be disconnected and bench tested so that the fault can be located.

Note.—All of the above conclusions assume that the alternator A.C. output figures were satisfactory. Any fault at the alternator will, of course, reflect on the rectifier test results. Similarly any fault in the charging circuit wiring may indicate that the rectifier is faulty. The best method of locating a fault is to disconnect the rectifier and bench-test as shown below:

BENCH TESTING THE RECTIFIER

For this test the rectifier should be disconnected and removed. Before removing the rectifier, disconnect the leads from the battery terminals to avoid the possibility of a short circuit occurring.

Connect the rectifier to a 12 volt battery and 1 ohm load resistor, and then connect the D.C. voltmeter in the V2 position, as shown in Fig. H10. Note the battery voltage (should be 12V) and then connect the voltmeter in V1 position whilst the following tests are conducted.

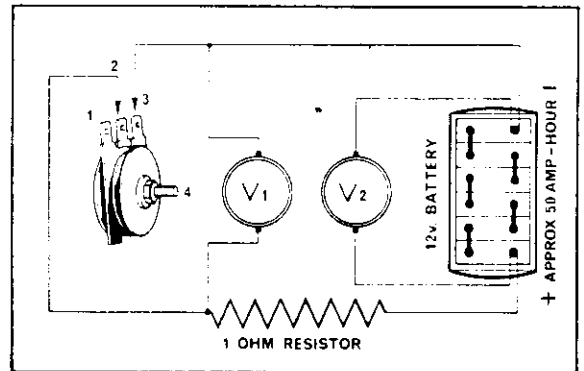


Fig. H8. Bench testing the rectifier

A voltmeter in position V1 will measure the volt drop across the rectifier plate. In position V2 it will measure the supply voltage to check that it is the recommended 12 volts on load.

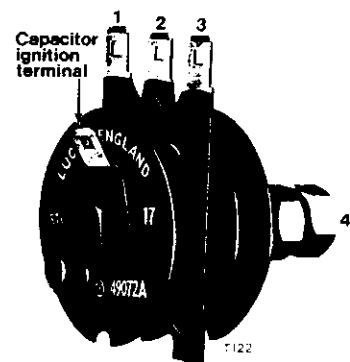


Fig. H9. Rectifier—showing terminal connections for bench tests 1 and 2

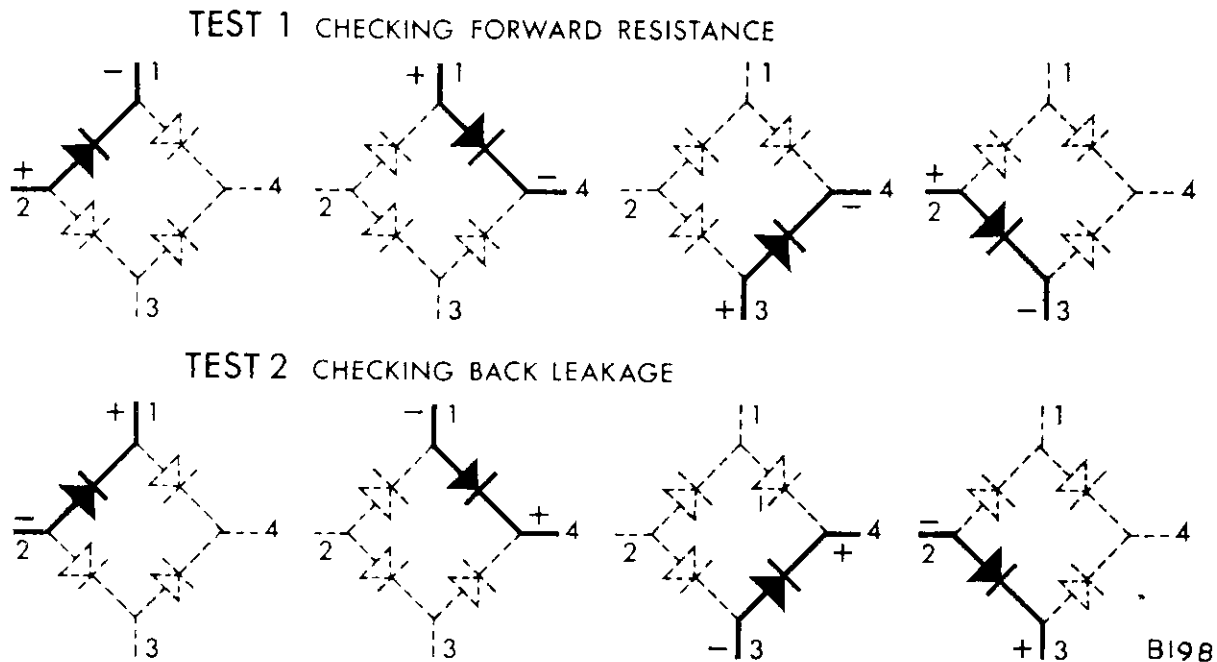


Fig. H10. Rectifier test sequence for checking forward resistance and back leakage

Test 1. With the test leads, make the following connections but keep the testing time as short as possible to avoid overheating the rectifier cell: (a) 1 and 2, (b) 1 and 4, (c) 3 and 4, (d) 3 and 2. Each reading should not be greater than 1.5 volts with the battery polarity as shown.

Test 2. Reverse the leads or battery polarity and repeat Test 1. The readings obtained should be battery voltage (V_2).

If the readings obtained are not within the figures given, then the rectifier internal connections are faulty and the rectifier should be renewed.

H5 PART D. CHECKING THE CHARGING CIRCUIT FOR CONTINUITY

Check that there is voltage at the battery and that it is correctly connected into the circuit +ve earth (ground). Ensure that the fuse has not blown.

- (1) First check that there is voltage at the rectifier centre terminal by connecting a D.C. voltmeter, with a 1 ohm load resistor parallel, between the rectifier centre terminal (not the end terminal) and earth (remember (+ve) positive earth (ground).

The voltmeter should read battery volts. If it does not, disconnect the alternator leads as the snap connectors under the engine unit.

- (a) Fit a jumper lead across the brown/blue and green/yellow connections at the rectifier, and check the voltage at the snap connector. This test will indicate whether the harness alternator lead is open circuit, or the fuse has blown.
- (b) Repeat this test at the rectifier for the white/green lead.

H5 PART E. CONSTRUCTING A ONE OHM LOAD RESISTOR

The resistor used in the following test must be accurate and constructed so that it will not overheat otherwise the correct values of current or voltage will not be obtained.

A suitable resistor can be made from 4 yards ($3\frac{1}{2}$ metres) of 18 S.W.G. (.048 in. (i.e. 1.2 mm.) dia.) NICHROME wire by bending it into two equal parts and calibrating it as follows:-

- (1) Fix a heavy gauge flexible lead to the folded end of the wire and connect this lead to the positive terminal of a battery.

- (2) Connect a D.C. voltmeter (0–15V) across the battery terminals and an ammeter (0–10 amp) between the battery negative and the free ends of the wire resistance, using a crocodile clip to make the connection.
- (3) Move the clip along the wires, making contact with both wires until the

ammeter reading is numerically equal to the number of volts indicated on the voltmeter. The resistance is then 1 ohm. Cut the wire at this point, twist the two ends together and wind the wire on an asbestos former approximately 2 inches (5 cm.) dia. so that each turn does not contact the one next to it.

SECTION H6

ZENER DIODE CHARGE CONTROL

DESCRIPTION

The Zener Diode output regulating system uses all the coils of the 6-coil alternator connected permanently across the rectifier, provides automatic control for the charging current. It will only operate successfully where it is connected in parallel with the battery as shown in the wiring diagram (Section H20 Fig. H28). The Diode is connected direct to the centre terminal of the rectifier.

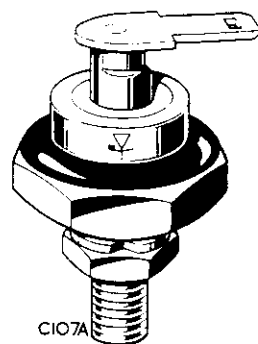


Fig. H11. Zener Diode

Assuming the battery is in a low state of charge its terminal voltage (the same voltage is across the Diode) will also be low, therefore the maximum charging current flow into the battery from the alternator. At first none of the current is by-passed by the Diode because of it being non-conducting due to the low battery terminal volts. However, as the battery is quickly restored to a full state of charge, the system voltage rises until at 13.5 volts the Zener Diode is partially

conducting, thereby providing an alternative path for a small part of the charging current. Small increases in battery voltage results in large increases in Zener conductivity until, at approximately 15 volts about 5 amperes of the alternator output is by-passing the battery.

The battery will continue to receive only a portion of the alternator output as long as the system voltage is relatively high.

Depression of the system voltage, due to the use of headlamp or other lighting equipment, causes the Zener Diode current to decrease and the balance to be diverted and consumed by the components in use.

If the electrical loading is sufficient to cause the system voltage to fall to 13.5 volts, the Zener Diode will revert to a high resistance state of non-conductivity and the full generated output will go to meet the demands of the battery.

With the specially designed heat sink, the Zener Diode is able to absorb the full output of the alternator.

MAINTENANCE

Provided a firm flat "metal to metal" contact is maintained between the base of the Diode and the surface of the heat sink, to ensure adequate heat flow, no maintenance will be necessary. Ensure that the earth connection to the diode is a good one.

ZENER DIODE

TEST PROCEDURE

(Procedure for Testing on the Machine)

The test procedure given below can be used when it is required to check the performance of the Zener Diode type ZD715 whilst it is in position on the machine. It is essential that the battery is in a fully charged state, otherwise the tests below will not be accurate. If in doubt, substitute a battery that is fully charged.

Good quality moving coil meters should be used when testing. The voltmeter should have a scale 0-18, and the ammeter 0-5 amps min. The test procedure is as follows:-

- (A) Disconnect the cable from the Zener Diode and connect ammeter (in series) between the diode Lucar terminal and cable previously disconnected. The ammeter red or positive lead must connect to the diode Lucar terminal.
- (B) Connect voltmeter across Zener Diode and heat sink. The red or positive lead must connect to the heat sink which is earthed to the frame of the machine by it fixing bolts and a separate earth lead. The

black lead connects to the Zener Diode Lucar terminal.

- (C) Start the engine, ensure that all the lights are off, and gradually increase engine speed while at the same time observing both meters:-
- (i) The series connected ammeter must indicate zero amps, up to 12.75 volts, which will be indicated on the shunt connected voltmeter as engine speed is slowly increased.
 - (ii) Increase engine speed still further, until Zener current indicated on ammeter is 2.0 amp. At this value the Zener voltage should be within 14.2 volts to 15.8 volts, (gold finished Zener) or 14.7 volts to 15.8 volts (silver).

TEST CONCLUSIONS:-

If the ammeter in test (i) registers any current at all before the voltmeter indicates 12.75 volts, then a replacement Zener Diode must be fitted.

If test (i) is satisfactory but in test (ii) a higher voltage than that stated is registered on the voltmeter, before the ammeter indicates 2.0 amp, then a replacement Zener Diode must be fitted.

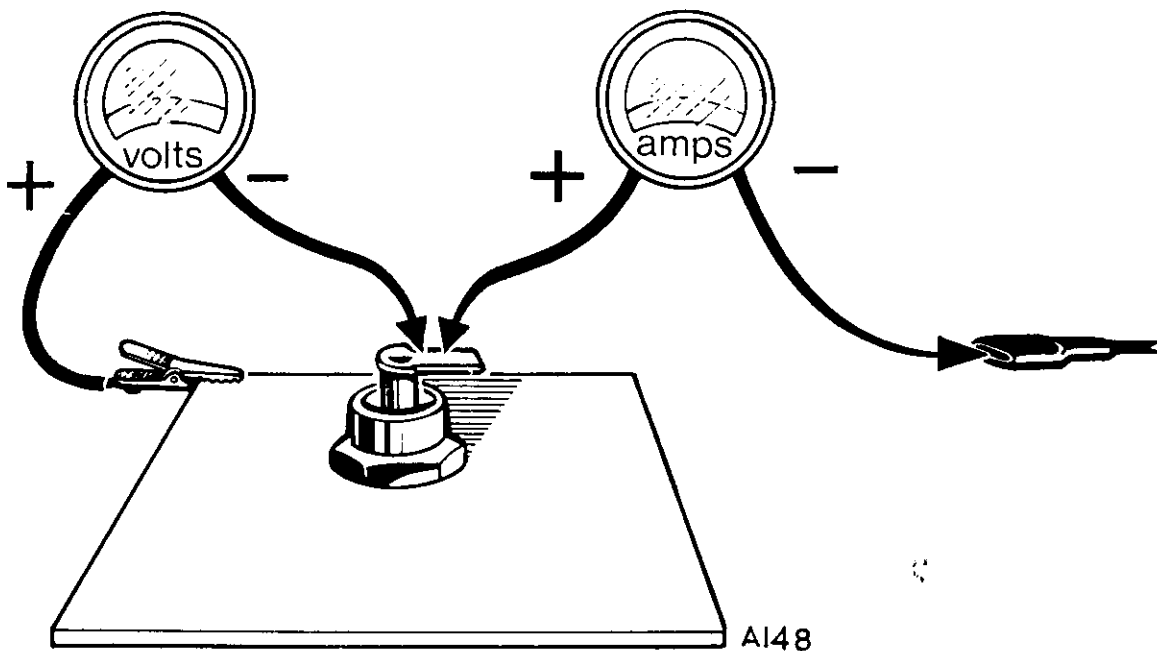


Fig. H12. Showing ammeter and voltmeter connections for test purposes

SECTION H7

ZENER DIODE LOCATION

The Zener Diode ("A" Fig. H13) is mounted on a bracket below the headlamp, and the aluminium heat-sink ("B" Fig. H13) is finned to assist cooling. The order of assembly is shown in Fig.H13.

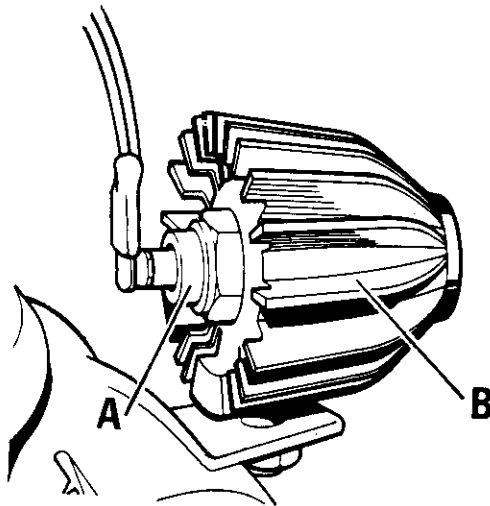


Fig. H13. Finned heatsink

To remove diode only, disconnect the brown/blue double "Lucar" connector from the diode. Remove the black plastic plug from the front of the heat sink (See Fig. H13) and unscrew the "nyloc" nut which secures the Diode. When refitting, the Diode nut must be tightened with extreme care. (Maximum tightening torque 22/28 lb./in.)

Take off the finned heat sink, remove the front bolt from the retaining bracket. A double red (ground) earth wire is attached at this point.

DO NOT ATTACH THE (GROUND) EARTH LEADS BETWEEN THE DIODE BODY AND HEATSINK

SECTION H8

ELECTRIC HORNS

DESCRIPTION

The horn is of a high frequency single note type and is operated by a direct current from the battery. The method of operation is that of a magnetically operated armature, which impacts on the cone face, and causes the tone disc of the horn to vibrate. The magnetic circuit is made self interrupting by contacts which can be adjusted externally.

If the horn fails to work, check the mounting bolts etc., and horn connection wiring. Check the battery for state of charge. A low supply voltage at the horn

will adversely affect horn performance.

If the horn still fails to operate, make the following checks:-

- (1) Eliminate the horn push circuit by earthing W1-terminal with a temporary wire. If the horns then operate, check the horn push and associated wiring.
- (2) Having carried out test one and the horn still fails to operate, apply a direct feed to the horn with a temporary link.

If the above checks are made and the fault persists, then adjust the horn as follows:-

HORN ADJUSTMENT

During adjustment it is advisable to depress the horn push for only a fraction of a second at a time. The horn adjustment screw is located at the back of the horn (a slotted cheese head screw, See Fig. H14).

Turn the screw clockwise or anti-clockwise a quarter turn at a time until the loudest clear note is delivered.

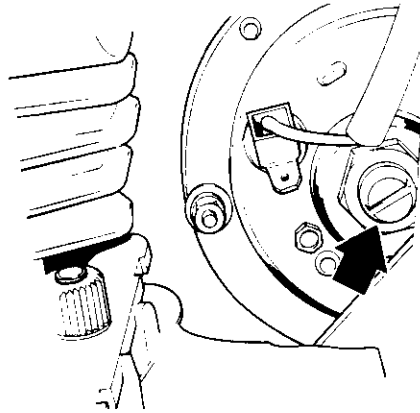


Fig. H14. Horn adjustment

SECTION H9**HEADLAMP****DESCRIPTION**

The headlamp is of the sealed beam unit type and access is gained to the bulb and bulb holder by withdrawing the rim and beam unit assembly. To do so, slacken the screw at the top of the headlamp ("B" Fig. H15), and prise off the rim and beam unit assembly.

The bulb can be removed by first pressing the cylindrical cap "D" inwards, and turning it anti-clockwise. The cap can then be withdrawn and the bulb is free to be removed.

When refitting a new bulb, note that it locates by means of a cutaway and projection arrangement.

Also note that the cap can only be replaced one way, the tabs being staggered to prevent incorrect reassembly. Check the replacement

bulb voltage and wattage specification and type before fitting. Focusing with this type of light unit is unnecessary and there is no provision for such.

A parking, or pilot bulb "E" is also used, being a "push-in" fit in the reflector.

BEAM ADJUSTMENTS

The beam must in all cases be adjusted as specified by local lighting regulations. In the United Kingdom the Transport Lighting Regulations read as follows:-

A lighting system must be arranged so that it can give a light which is incapable of dazzling any person standing on the same horizontal plane as the vehicle at a greater distance than twenty five feet from the lamp, whose eye level is not less than three feet-six inches above that plane.

The headlamp must therefore be set so that the main beam is directed straight ahead and parallel with the road when the motorcycle is fully loaded. To achieve this, place the machine on a level road pointing towards a wall at a distance of 25 feet away, with a rider and passenger, on the machine, slacken the two pivot bolts either side of the headlamp and tilt the headlamp until the beam is focused at approximately two feet six inches from the base of the wall. Do not forget that the headlamp should be on "full-beam" lighting during this operation.

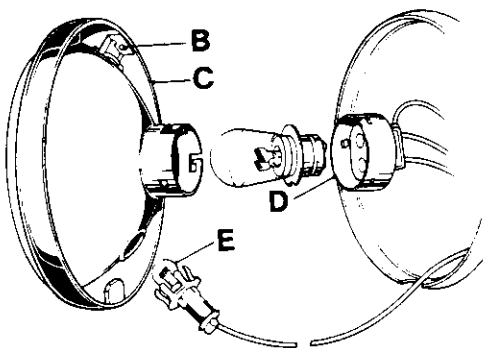


Fig. H15. The headlight assembly

SECTION H10

REMOVING AND REFITTING THE HEADLAMP

Disconnect the leads from the battery terminals then slacken the light unit securing screw at the top of the headlamp. Prise the rim of the light unit free. Detach the pilot bulbholder from the unit, and disconnect the three bulbholder leads at the snap connectors. Disconnect the two terminals from the switch by loosening the small retaining screws. Pull out the warning light bulbs from their holders at the back of the shell, and disconnect the red ground (earth) wire. The indicator body and attachment stalk can be removed from the headlamp by unscrewing the nut situated against the headlamp bracket.

This nut is an integral part of the attachment stalk, and screws into a captive nut on the inside of the headlamp shell.

By bending the two retaining clips away from the rubber grommet at the rear of the headlamp shell, it will be possible to remove the harness through the resulting aperture. Reassembly is the reversal of the above procedure, but reference should be made to the wiring diagram in Section H20. Finally set the headlamp main beam as detailed in Section H9.

SECTION H11

TAIL AND STOP LAMP UNIT

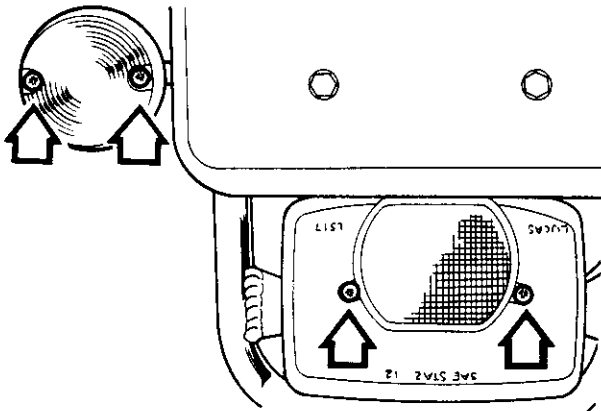


Fig. H16. Access to tail/stop light and direction indicator bulbs

Access to the bulbs in the tail and stop lamp unit is achieved by unscrewing the two slotted screws which secure the lens. The bulb is of the double-filament offset pin type and when a replacement is carried out, ensure that the bulb is fitted correctly.

Check that the two supply leads are connected correctly and check the ground (earth) lead to the bulb holder is in satisfactory condition.

When refitting the lens, do not overtighten the fixing screws or the lens may fracture as a result.

SECTION H12

FUSES

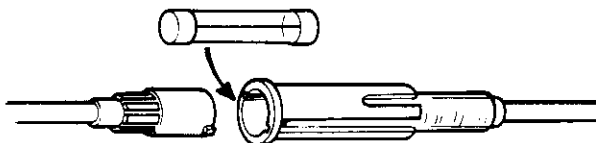


Fig. H17. Exploded view of fuseholder assembly

The fuse is to be found on the brown/blue live lead from the battery negative terminal. It is housed in a quickly detachable shell and is of 35 amp fuse rating.

Before following any fault location procedure always check that the fuse is not the source of the fault. A new fuse-cartridge should be fitted if there is any doubt about the old one.

The fuse rating must not under any circumstances be above 35 amp.

SECTION H13

LIGHTING AND IGNITION SWITCH

The machine is fitted with an ignition switch incorporating a "barrel" type lock. These locks use individual keys, and render the ignition circuit inoperative when the switch is turned off and the key removed. It is advisable for the owner to note the number stamped on the key to ensure a correct replacement in the event of the key being lost. (See wiring diagram, Fig. H28 for switch positions).

Access to the switch is obtained by raising the binnacle cover, as shown in Fig. H18, after carefully taking out the three retaining screws. To remove the two rear screws, however, it will be necessary to lift the handlebar assembly, after taking off the nuts holding the handlebar clamps to the top yoke of the fork. Take care not to damage the front brake flexible pipe.

The battery leads should be removed before attempting to remove the switch to avoid a short circuit. The lock is retained in the body of the switch by a spring loaded plunger. This can

be depressed with a pointed instrument through a small hole in the side of the switch body and the lock assembly withdrawn after the lock and switch together have been detached from the machine.

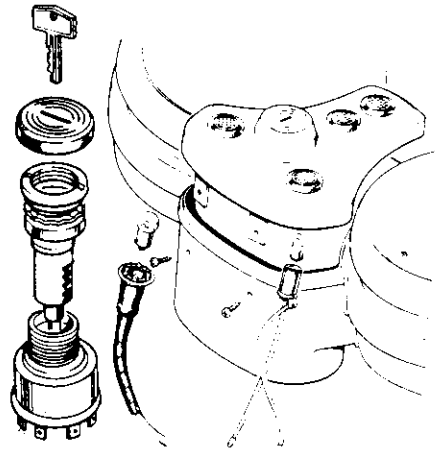


Fig. H18. The binnacle assembly and ignition switch

SECTION H14

FLASHER LAMPS

Access to the bulb in the flasher lamp can be obtained by unscrewing the two cross head screws. To remove the bulb, depress inwards and turn anti-clockwise. When replacing the bulb make sure it is securely fitted.

REMOVING AND REFITTING FRONT FLASHER LAMPS

Remove headlamp rim and light unit (See Section H10). Disconnect the green/white wire from the snap connector. Remove the flasher lamp by slackening the locking nut and turning the lamp unit anti-clockwise.

Finally pull the wire through the flasher lamp stalk. When refitting, check the general data for locking nut torque.

REMOVING AND REFITTING REAR FLASHER LAMPS

Disconnect the battery terminals, remove the tail lamp support, refer to Section H11. Disconnect the green/white or green/red wires at the Snap Connectors and proceed as in the removal of the front flasher unit.

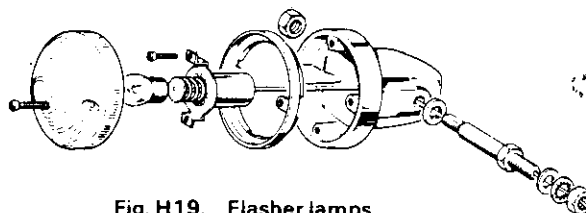


Fig. H19. Flasher lamps

SECTION H15

WARNING LAMPS

Warning lamps are fitted into the binnacle assembly, mounted on the handlebars. (Fig. H20). The blue light (A) indicates high beam. The amber warning light (B) serves the flasher lamps, and becomes illuminated in conjunction with them when they are operational.

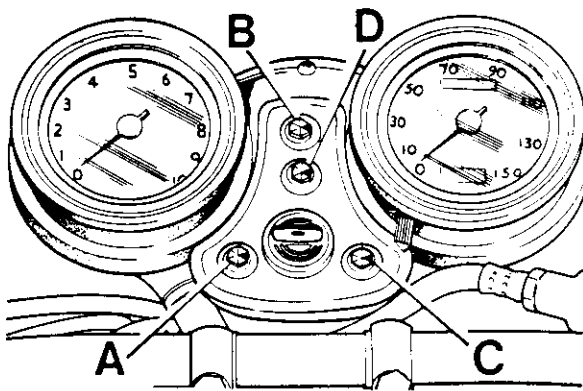


Fig. H20. The warning lights

The red warning light (C) is connected into the ignition circuit, and also to an electrically controlled oil pressure switch, situated at the timing cover.

This results in the warning light operating as soon as the ignition is turned on, with the engine stopped, but extinguishes as oil pressure develops beyond a predetermined minimum critical pressure when the motor is running. If the red light comes on during normal running, the engine should be stopped, and an investigation made immediately, in an effort to determine the cause of the problem. Serious damage to the unit could arise if there is any shortage of lubrication. Neutral gear, between first and second ratios, is indicated by a green light (D). This comes on only when neutral is engaged.

Access to the bulbs themselves can be obtained by the method described in Section H13.

SECTION H16

STOP LAMP SWITCHES

The front and rear stop lamp switches are both sealed units requiring no maintenance, other than a routine check on the security and cleanliness of terminals. The front stop switch is fitted into the front brake operating lever (see section F9), whilst the rear stop switch is located on the right side rear engine plate, near the pivot of the rear brake operating lever.

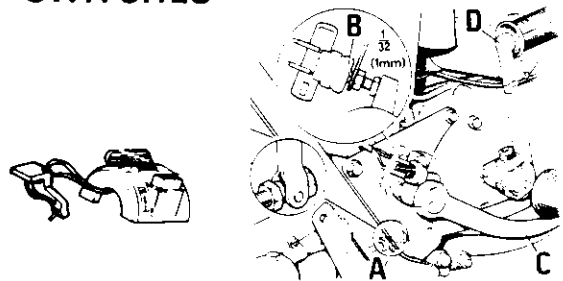


Fig. H21. Front and rear stop lamp switches

SECTION H17

OIL PRESSURE SWITCH

The oil pressure switch is a sealed unit fitted into the crankcase behind the oil pump. The oil switch is designed to operate at 7–11 lb. pressure, at which stage the oil warning light will be extinguished. There is no simple method of checking the function of the switch, except by substitution.

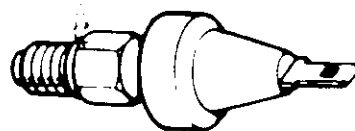


Fig. H22. Oil pressure switch

SECTION H18

CAPACITOR IGNITION (MODEL 2MC) ALTERNATIVE SYSTEM

The Lucas motor cycle capacitor system has been developed to enable machines to be run with or without a battery. The rider therefore has the choice of running with normal battery operation or running without battery if desired (e.g. competing in trials or other competitive events) and for emergency operation in case of battery failure.

Machines can readily be started without the battery and run as normal with full use of standard lighting. When stationary, however, parking lights will not work unless the battery is connected. The capacitor system also has the advantage of being less critical with regard to alternator timing.

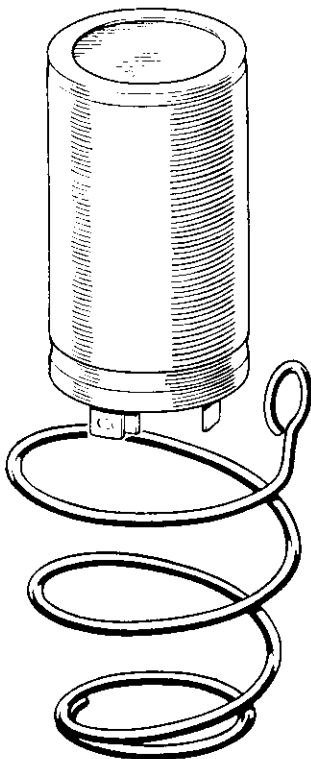


Fig. H23. Capacitor and spring

The system utilises the standard 12-volt battery-coil ignition equipment with the Zener Diode charging regulator mounted on an efficient heat sink, plus a spring mounted high capacity electrolyte capacitor (Model 2MC), of a special shock-resistant type.

The energy pulses from the alternator are stored by the capacitor to ensure that sufficient current flows through the ignition coil at the moment of contact opening, thus producing an adequate spark for starting. When running, the capacitor also helps to reduce the D.C. voltage ripple.

Also with this system alternator timing is less critical. Provided the centre of the rotor and stator poles are roughly in line in the fully retarded position (i.e. as normal battery) emergency start condition which is 30° past magnetic neutral, satisfactory starting will be obtained. Furthermore any auto-advance angle and speed characteristics may be used and perfect running ignition performance achieved.

IDENTIFICATION OF CAPACITOR TERMINALS

The 2MC capacitor is an electrolyte (polarised) type and care must be taken to see that the correct wiring connections are made when fitting. Spare Lucas connectors are supplied to assist in connecting up. Looking at the terminal end of the unit it will be seen that there are two sizes of Lucas connector. The small $\frac{3}{16}$ in. Lucas is the *positive* (earth) terminal the rivet of which is marked with a spot of red paint. The double $\frac{1}{4}$ in. Lucas forms the *negative* terminal.

Fig. H23 shows the spring and capacitor. The capacitor should be positioned with its terminals pointed downwards. When fitting the spring to the capacitor, insert the capacitor at the widest end of the spring and push it down until the small coil locates in the groove on the capacitor body.

STORAGE LIFE OF MODEL 2MC CAPACITOR

The life of the 2MC is very much affected by storage in high temperature. The higher the temperature the shorter its shell life. At normal temperature i.e. 20°C. (68°F.) it will have a shelf life of about 18 months. At 40°C. (86°F.) about 9 to 12 months. Therefore, storing in a cool place will maintain their efficiency.

TESTING

The efficiency of a stored capacitor can be determined fairly accurately with the aid of a voltmeter (scale 0–12 volts) connected to the terminals of a charged capacitor and the steady, not instantaneous reading on the meter noted. The procedure is as follows:–

- (a) Connect the capacitor(s) to a 12-volt supply and leave connected for 5 seconds. Observe carefully the polarity of connections, otherwise the capacitor may be ruined.
- (b) Disconnect the supply leads and allow the charged capacitor to stand for at least *5 minutes*.
- (c) Connect the voltmeter leads to the capacitor and note the steady reading. This should not be less than 9.0 volts for a serviceable unit.
If the reading is less than 9.0 volts, the capacitor is leaking and must be replaced.

If a voltmeter is not available a rough check can be made by following the procedures in (a) and (b) and using a single strand of copper wire instead of the voltmeter to short-circuit the capacitor terminals. A good spark will be obtained from a serviceable capacitor at the instant the terminals are shorted together.

WIRING AND INSTALLATION

The capacitor is fitted into the spring and should be mounted with its terminals downwards. The capacitor negative terminal *and* Zener Diode must be connected to the rectifier centre (D.C.) terminal (brown/white), and the positive terminal must be connected to the centre bolt earthing terminal.

The mounting spring should be attached to any convenient point near the battery carrier.

SERVICE NOTES

Before running a 2MC equipped machine with the battery disconnected it is essential that the *battery negative lead be insulated* to prevent it from reconnecting and shorting to earth (frame of machine). Otherwise, the capacitor will be ruined. This can be done by removing the fuse from its holder and replacing it with a length of $\frac{1}{2}$ in. dia. dowel rod or other insulating medium.

A faulty capacitor may not be apparent when used with a battery system. To prevent any inconvenience arising, periodically check that the capacitor is serviceable by disconnecting the battery to see if the machine will start and run in the normal manner, with full lighting also available.

WARNING

Do not run the machine with the Zener Diode disconnected, as the 2MC capacitor will be damaged due to excessive voltage.

Should the engine fail to start without the battery, substitute a new 2MC capacitor. If the engine still refuses to start, check the wiring between the capacitor and rectifier for possible open or short circuit conditions. Also check the earth connections.

If difficulty is encountered in starting with a battery fitted, disconnect the 2MC capacitor to eliminate the possibility of a short circuit

SECTION 19

THE STARTER MOTOR CIRCUIT

DESCRIPTION

The starter motor circuit consists of the handlebar starter switch, the starter relay, the electric starter motor, an electric solenoid, a housing with bearings, an intermediate shaft, a lever mechanism, and an engaging pinion.

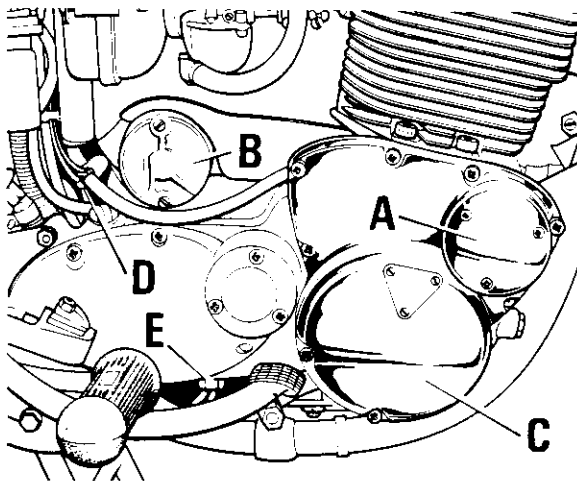


Fig. H24. The Alternator, Starter and Contact Breaker

- A. IGNITION CONTACT BREAKER COVER.
- B. STARTER MOTOR AND SOLENOID
- C. ALTERNATOR HOUSING
- D. GENERATOR SNAP CONNECTORS
- E. NEUTRAL INDICATOR SWITCH

When the handlebar starter switch is operated, the starter relay is energised. This firstly connects the starter motor via the solenoid to the battery, at the same time shorting out the ballast resistor in the ignition circuit. The solenoid action operates the lever mechanism, which engages the starter pinion with the clutch. When the solenoid has reached the end of its travel, it energises the motor, which then cranks the engine. A one-way clutch is built in to overcome any problem of the engine driving the starter motor after firing.

Secondly, as a result of operating the handlebar switch, the starter relay performs a second function, i.e. that of by-passing the ignition coil feed ballast resistor.

The ballast resistor normally maintains the correct operating voltage for the 6 volt ignition coils in the machine's own 12 volt circuit. However, when the starter motor is operated, the current drain reduces the circuit

voltage. It is then that the ballast resistor is by-passed by the starter relay allowing the reduced battery voltage to operate directly on the 6 volt coils, thereby producing the full spark plug starting H.T. voltage requirements.

STARTER FAILS TO OPERATE

Check that the battery is fully charged.

If the starter fails to operate, both solenoid/ starter circuit and the relay circuit must be checked for continuity. Using a D.C. voltmeter with one probe to the battery positive post, ensure battery voltage is available at the W2 connection of the relay (ignition on, starter button depressed). If not, check back along the circuit until battery voltage is available. Ensure the W2 connection is properly earthed.

With the voltmeter still connected, check voltage is available at C1 of relay. If not, check back. If available, move to C2 and depress starter button (ignition on). Battery voltage should be available.

Move on to

- (a) Live side of solenoid
- (b) Starter side of solenoid contacts
- (c) Starter main terminal

Battery voltage should be available at all points with ignition switch on, and starter button depressed. If voltage is available but the starter still does not work, check that the starter is properly earthed.

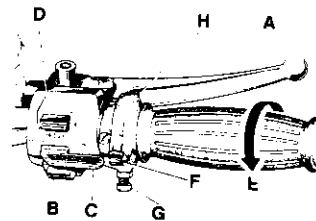


Fig. H25. The Right Handlebar Switch

ITEM D IS THE STARTER SWITCH

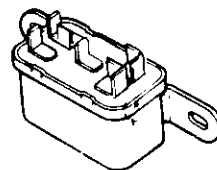


Fig. H26. Starter Relay

STARTER MOTOR SLUGGISH

Check that the battery is fully charged.

If the starter motor operates, but only slowly, and with great effort, the main starter circuit should be checked for voltage drop. Disconnect the ignition coils by removing connections, or depressing the "kill button". Using a D.C. voltmeter, connect one probe to battery positive, and other probe to battery negative. This provides a "battery voltage" value. Move probe from battery negative to main feed terminal of solenoid. Voltage reading should not be more than $\frac{1}{2}$ volt below reading across battery. If more than this, replace cable.

Move probe from battery positive to solenoid starter connection. Voltage reading should not be more than $\frac{1}{2}$ volt below reading across battery. If more, clean and tighten solenoid connections and re-test. If still reading more than $\frac{1}{2}$ volt, replace solenoid.

Move probe from solenoid starter terminal to starter terminal, and probe from solenoid feed terminal to solenoid starter terminal. Depress starter button. If volt drop exceeds $\frac{1}{2}$ volt, replace cable.

Move probe from starter terminal to starter body, and probe from solenoid starter terminal to starter terminal. Depress starter button. Volt drop should not exceed $\frac{1}{2}$ volt. If more, remove starter. Move probe from starter body to earth stud on engine, and probe from starter terminal to starter body. Depress starter button. Volt drop should not exceed $\frac{1}{2}$ volt. If more, remove starter, clean the starter/engine mating faces, and retighten.

Move probe from engine earth stud to battery positive terminal, and from starter body to engine earth stud. Depress starter button. Volt drop should not exceed $\frac{1}{2}$ volt. If more, replace

cable. The total volt drop between negative and starter body, and between starter body and battery positive, must not exceed one volt. If it does, all connections must be removed, cleaned, and retightened.

TO REMOVE STARTER ASSEMBLY

Disconnect battery leads. Remove the starter solenoid leads and three screws securing the housing to the clutch cover. Lift assembly clear.

TO REMOVE DRIVE ASSEMBLY

Tap back circlip collar. Remove circlip on intermediate shaft. Remove pivot pin. Slide drive assembly off intermediate shaft, together with lever mechanism and solenoid plunger. Remove circlip at rear of drive, and separate from override spring. Remove lever. The drive can be serviced complete, or the override spring only replaced.

TO REMOVE SOLENOID

Remove solenoid/starter lead. Take off the remaining solenoid nut. Slide solenoid off plunger, collecting the return spring. Lift the plunger off the lever assembly.

The solenoid can be serviced complete, or the return spring only changed. (It should be noted that replacement solenoids are supplied less nuts. Care should be taken, therefore, to ensure that the original nuts are not misplaced).

TO REMOVE THE STARTER MOTOR

Take off the starter/solenoid lead. Remove two nuts from the housing studs, and take out the headed screw inside the housing (behind the drive). Before reassembling, ensure that the pinion has adequate lubrication by careful greasing.

The starter motor can be serviced complete, or stripped down, and specific parts replaced.

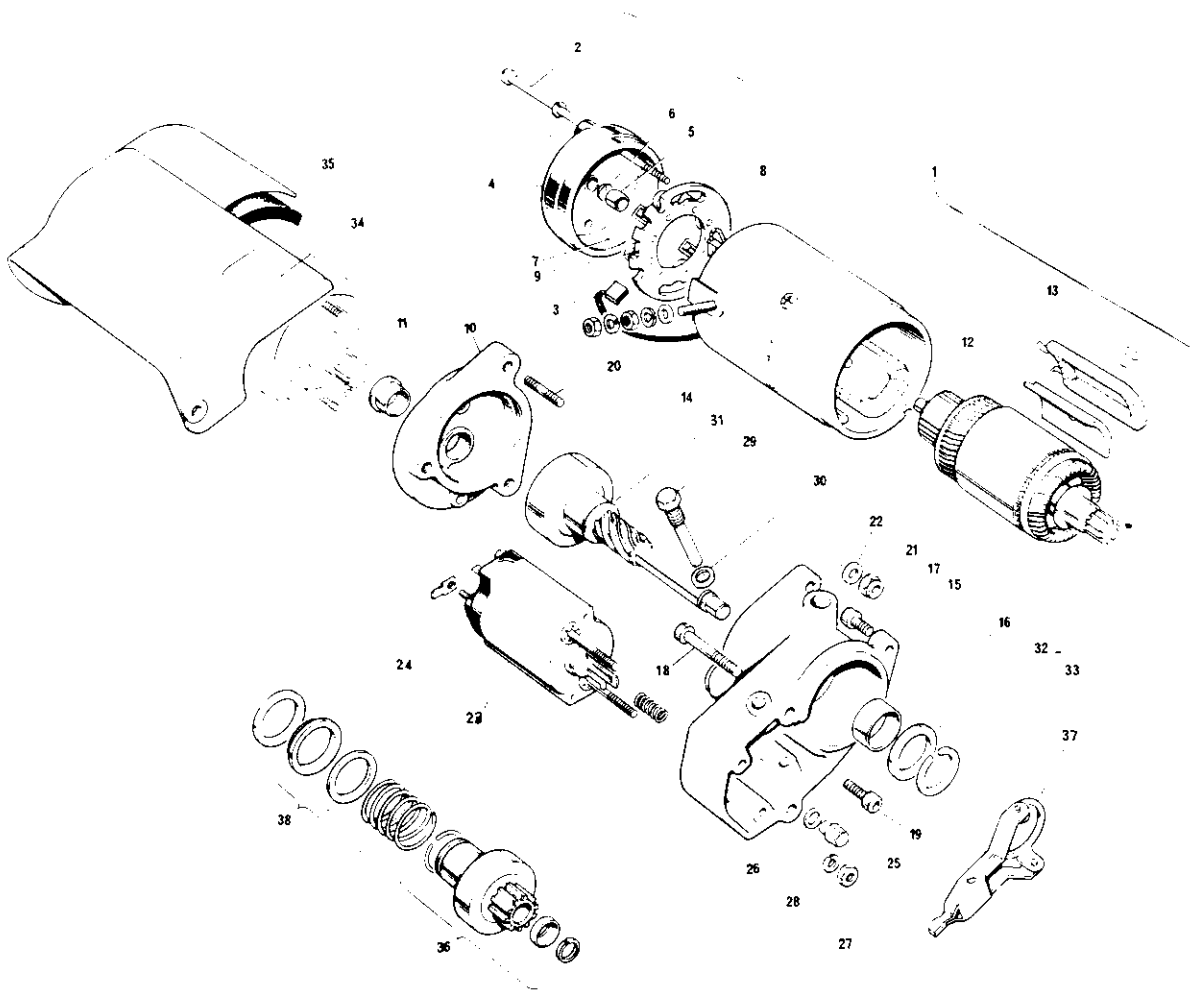
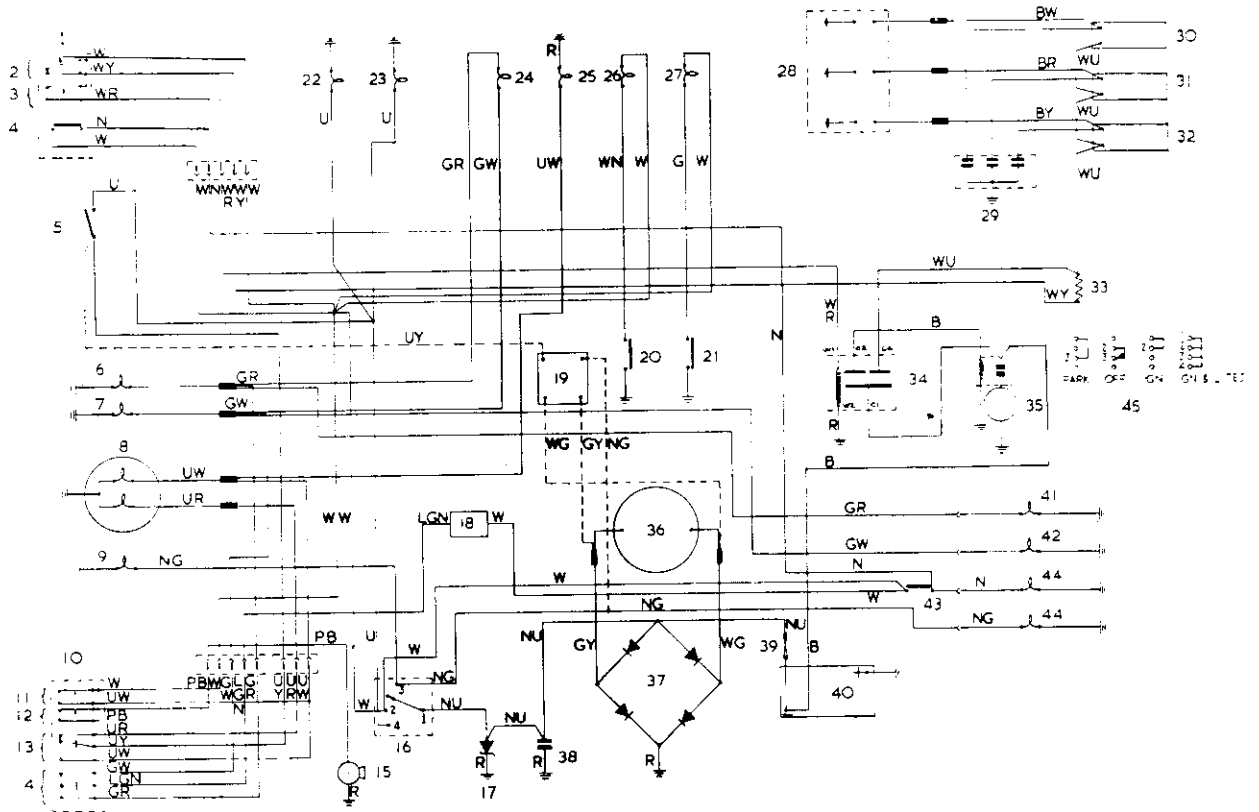


Fig. H27. Electric Starter Mechanism

- | | | |
|--------------------------|---------------------------------------|--|
| 1 STARTER MOTOR COMPLETE | 14 FIELD TERMINAL | 27 NUT |
| 2 THROUGH FIXING BOLT | 15 SOLENOID HOUSING | 28 WASHER |
| 3 BRUSHES | 16 INTERMEDIATE SHAFT BUSH | 29 DRIVE ASSEMBLY PIVOT PIN |
| 4 COMMUTATOR END BRACKET | 17 HOUSING TO CLUTCH COVER SCREW | 30 PIVOT PIN WASHER |
| 5 BEARING BUSH | 18 HOUSING TO CLUTCH COVER SCREW | 31 INTERMEDIATE SHAFT ASSEMBLY |
| 6 THRUST PAD | 19 HOUSING TO END DRIVE BRACKET SCREW | 32 INTERMEDIATE GEAR THRUST WASHER |
| 7 INSULATING LINER | 20 HOUSING TO END DRIVE BRACKET STUD | 33 THRUST WASHER CIRCLIP |
| 8 PLATE COMPLETE | 21 NUT FOR HOUSING STUD | 34 STARTER MOTOR COVER |
| 9 SPRING SET | 22 WASHER | 35 RUBBER PAD |
| 10 END DRIVE BRACKET | 23 SOLENOID | 36 DRIVE ASSEMBLY |
| 11 BEARING BUSH | 24 LUCAR TERMINAL | 37 LEVER ASSEMBLY |
| 12 ARMATURE | 25 SOLENOID SLEEVE NUT | 38 OVERRIDE SPRING AND SPACER ASSEMBLY |
| 13 FIELD COILS | 26 WASHER | |

SECTION H20
WIRING DIAGRAM



WIRING DIAGRAM SYMBOLS

- | | |
|---|---|
| <ul style="list-style-type: none"> 1 RIGHT HANDLEBAR SWITCH GROUP 2 KILL SWITCH 3 STARTER SWITCH 4 FRONT BRAKE SWITCH 5 HEADLITE/PARK SWITCH 6 FRONT DIRECTION INDICATOR (left) 7 FRONT DIRECTION INDICATOR (right) 8 HEADLITE BULB (Main beam, upper)
(Dipped beam, lower) 9 PARKING BULB 10 LEFT HANDLEBAR SWITCH GROUP 11 HEADLITE FLASHER (except earlier models) 12 HORN SWITCH 13 HEADLITE BEAM (Dipped, upper)
(Main, lower) 14 DIRECTION INDICATOR SWITCH (Upper RH)
(Centre off)
(Lower LH) 15 HORN 16 PANEL LIGHTING-IGNITION SWITCH 17 ZENER-DIODE 18 DIRECTION INDICATOR "FLASHER" UNIT 19 HEADLITE WARNING UNIT
(North America only) 20 OIL PRESSURE SWITCH 21 NEUTRAL INDICATOR SWITCH | <ul style="list-style-type: none"> 22 SPEEDOMETER 23 TACHOMETER 24 WARNING LITE (direction indicator) 25 WARNING LITE (main headlight beam) 26 WARNING LITE (oil pressure) 27 WARNING LITE (neutral switch) 28 CONTACT BREAKER ASSEMBLY 29 CAPACITORS 30 COIL RH 31 COIL CENTER 32 COIL LH 33 BALLAST RESISTOR 34 STARTER RELAY 35 STARTER 36 ALTERNATOR 37 RECTIFIER 38 ELECTROLYTIC CAPACITOR
(Not standard fitment) 39 FUSE 40 BATTERY 41 REAR DIRECTION INDICATOR (left) 42 REAR DIRECTION INDICATOR (right) 43 REAR BRAKE SWITCH 44 STOP/REAR LITE (Stop-upper)
(Rear-lower) 45 LIGHTING AND IGNITION SWITCH POSITIONS |
|---|---|

- SNAP CONNECTORS
- GROUND (Earth)

CABLE COLOR CODE

- | | |
|---|--------|
| B | BLACK |
| U | BLUE |
| N | BROWN |
| G | GREEN |
| Y | YELLOW |
| P | PURPLE |
| R | RED |
| W | WHITE |
| D | DARK |
| L | LITE |

Fig. H28. Wiring Diagram

SECTION J

WORKSHOP SERVICE TOOLS

INTRODUCTION

This section of the Workshop Manual illustrates pictorially the workshop service tools that were once available for carrying out the major dismantling and re-assembly operations on the 750 c.c. Trident Motorcycle. The author's felt that providing these illustrations would in many cases facilitate local fabrication or adaption from existing equipment.

The section is divided into sub-sections relating to the main section heading in this manual, illustrating:-

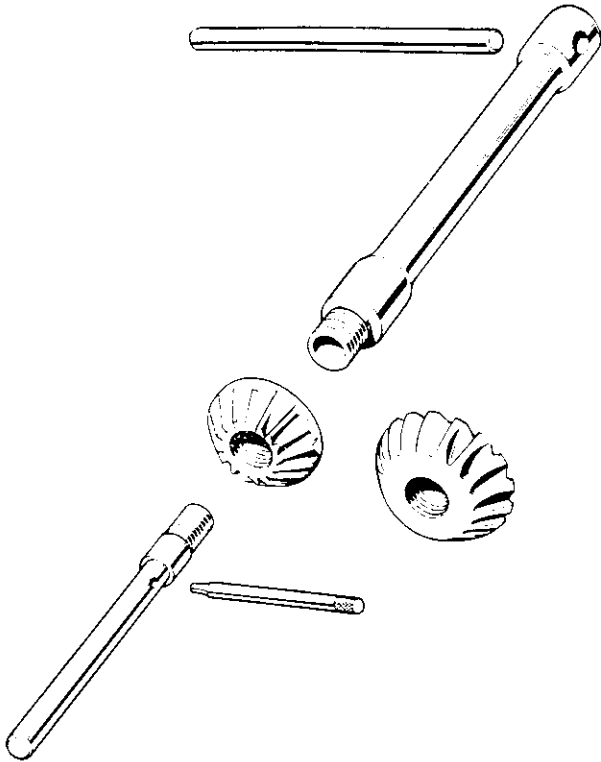
- (a) those tools mentioned and used in the appropriate section text;
- (b) certain tools that may be found useful, but are not mentioned in the text.

	<i>Section</i>
ENGINE	J1
TRANSMISSION	J2
WHEELS	J3
FRONT FORKS	J4
FRAME	J5

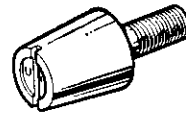
Note: Superseding Triumph (Meriden) Part numbers are provided in brackets.

SECTION J1

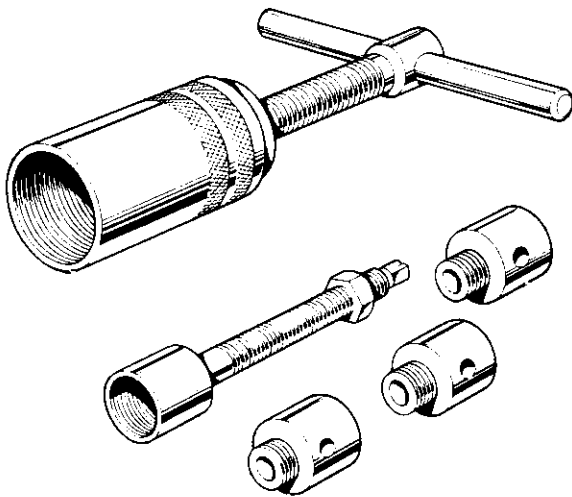
ENGINE



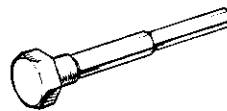
- 60-D1833. Valve seat cutter (inlet) (61-7026)
- 60-D1832. Valve seat cutter (exhaust) (61-7025)
- 60-D1836. Blending cutter (inlet) (61-7028)
- 60-D1835. Blending cutter (61-7027)
- 60-D1863. Arbor, pilot and tommy bars (61-7029)



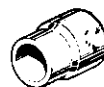
60-D1810. Camshaft oil seal protector



60-D2213 (61-3801) Camshaft pinion extractor and replacer with adaptors

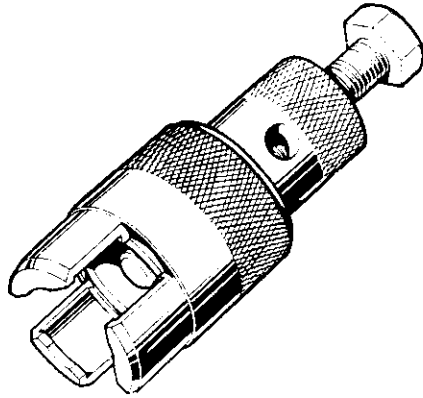


(60-0782) Contact breaker cam extractor

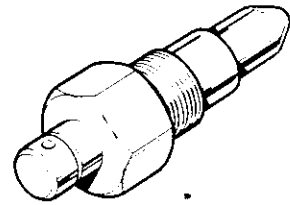


(60-2221) Rocker spindle oil seal compressor

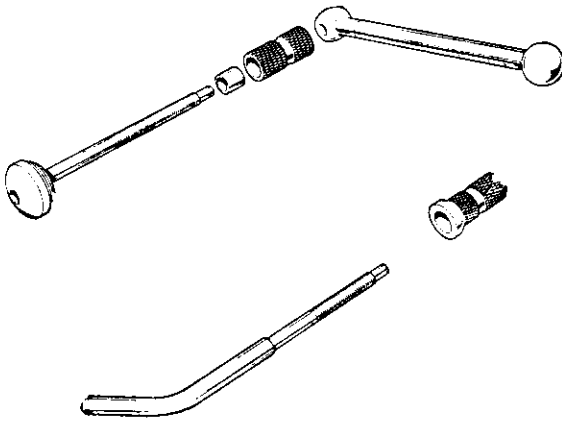
ENGINE (CONTINUED)



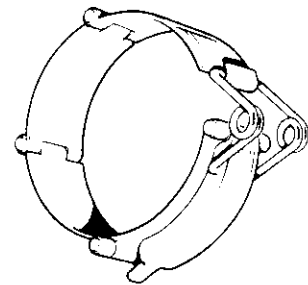
61-6019 Crankshaft pinion extractor



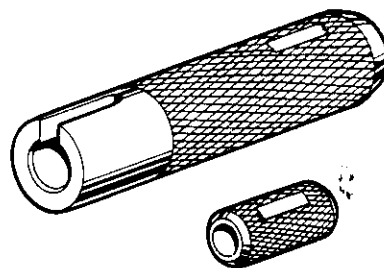
(60-1858) Ignition timing plug and body



61-6063 Valve guide removal and replacement tool

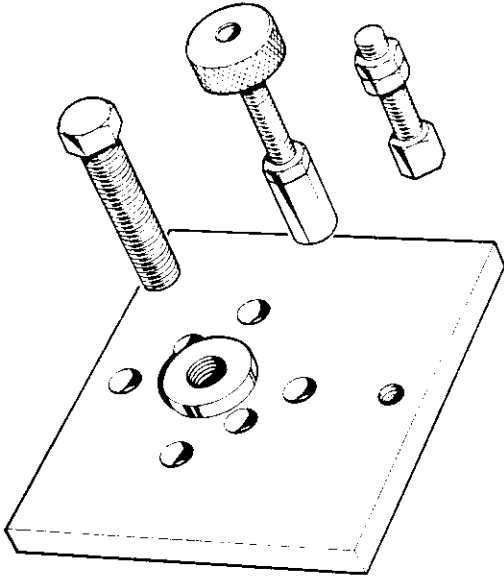


61-6052 Piston ring clamp

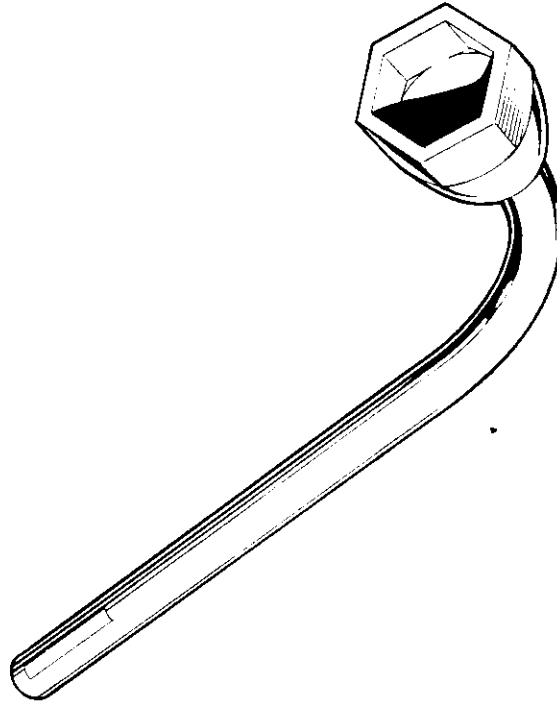


61-6024 Crankshaft pinion replacement drift and guide

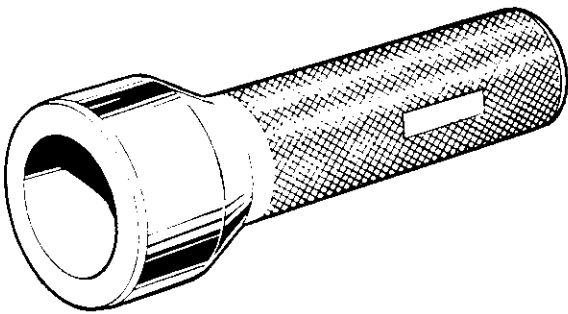
ENGINE (CONTINUED)



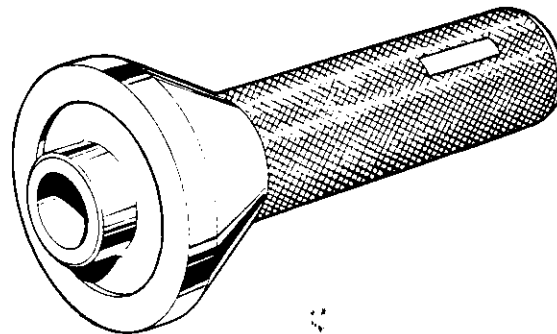
61-6046 Engine and gearbox sprocket extractor



(60-2135) Oil pressure release valve spanner

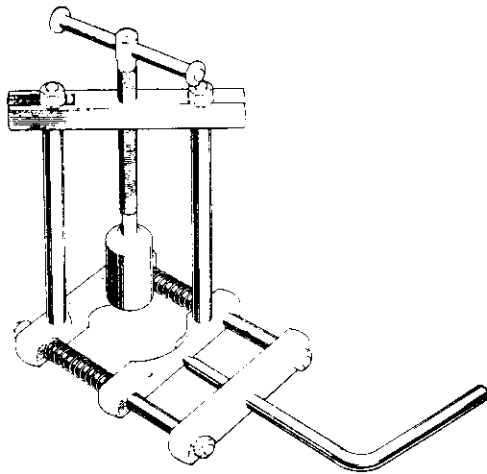


61-6020 Timing side main bearing outer spool drift

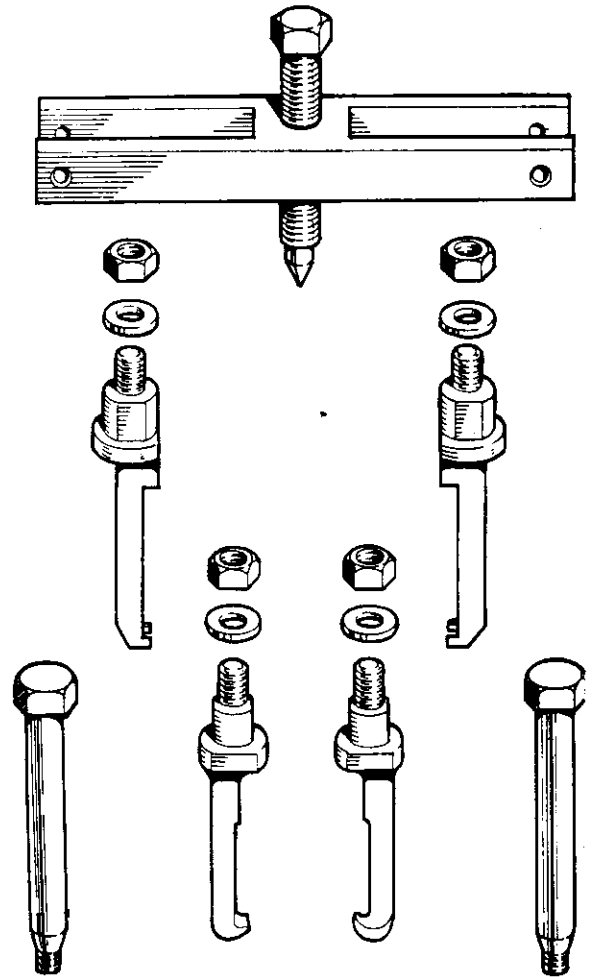


61-6021 Drive side main bearing drift

ENGINE (CONTINUED)



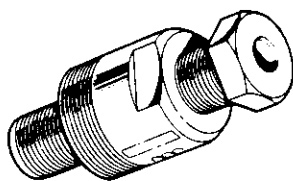
60-3677 Crankshaft bearing removal tool (inner race)



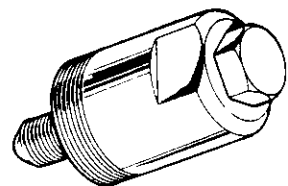
61-3808 Universal extractor

SECTION J2

TRANSMISSION

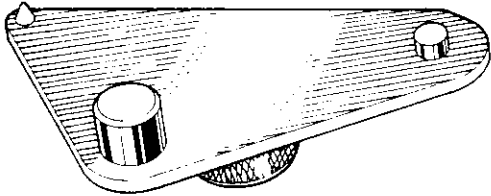


60-1862 Shock absorber extractor

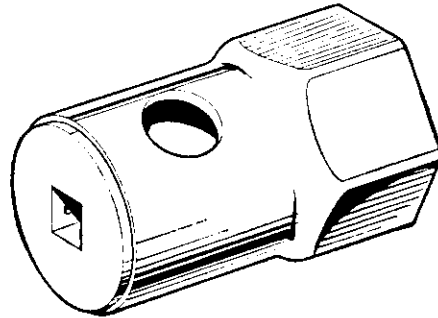


60-1860 Clutch hub extractor

TRANSMISSION (CONTINUED)



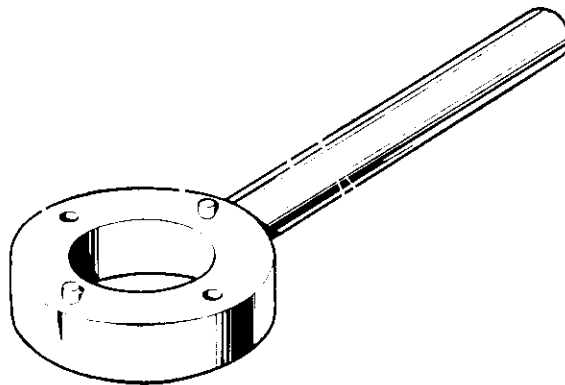
61-7011 Bottom gear fixture
(for 5 speed left footshift gearboxes)



61-6061 Gearbox sprocket nut box spanner

SECTION J3

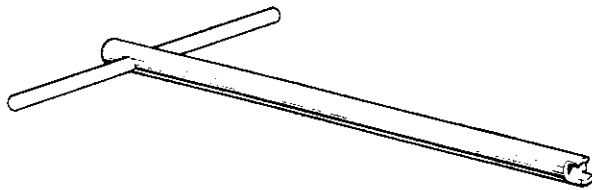
WHEELS



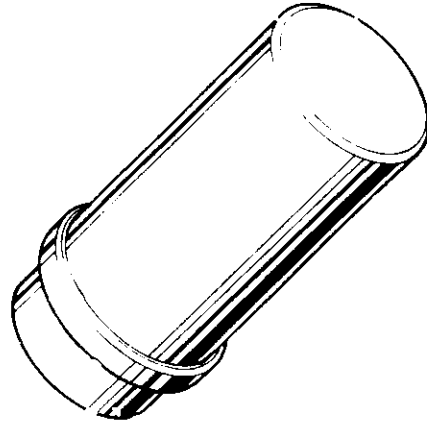
61-3694 Wheel bearing retainer peg spanner
(61-7024)

SECTION J4

FRONT FORKS



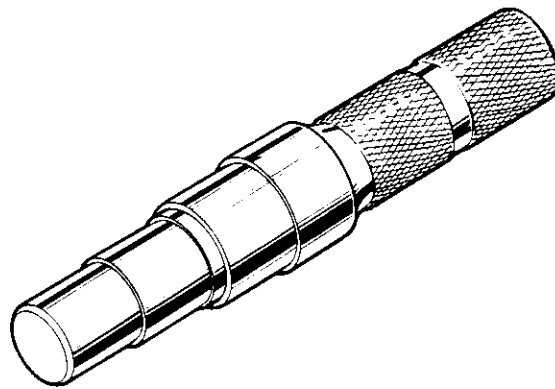
Fork damper valve removal tool No. 61-6113



Headrace bearing drift 61-6121

SECTION J 5

FRAME



61-6050 Swinging arm bush assembly tool

**CONVERSION
TABLES**

INCHES TO MILLIMETRES—UNITS

Inches	0	10	20	30	40
0		254·0	508·0	762·0	1016·0
1	25·4	279·4	533·4	787·4	1041·4
2	50·8	304·8	558·8	812·8	1066·8
3	76·2	330·2	584·2	838·2	1092·2
4	101·6	355·6	609·6	863·6	1117·6
5	127·0	381·0	635·0	889·0	1143·0
6	152·4	406·4	660·4	914·4	1168·4
7	177·8	431·8	685·8	939·8	1193·8
8	203·2	457·2	711·2	965·2	1219·2
9	228·6	482·6	736·6	990·6	1244·6

One Inch—25·399978 millimetres

One Metre—39·370113 inches

One Mile—1·6093 kilos

One Kilo—62138 miles

DECIMALS TO MILLIMETRES—FRACTIONS

1/1000	
inches	mm.
·001	·0254
·002	·0508
·003	·0762
·004	·1016
·005	·1270
·006	·1524
·007	·1778
·008	·2032
·009	·2286

1/100	
inches	mm.
·01	·254
·02	·508
·03	·726
·04	1·016
·05	1·270
·06	1·524
·07	1·778
·08	2·032
·09	2·286

1/10	
inches	mm.
·1	2·54
·2	5·08
·3	7·62
·4	10·16
·5	12·70
·6	15·24
·7	17·79
·8	20·32
·9	22·86

FRACTIONS TO DECIMALS AND MILLIMETRES

Fractions		Decimals	mm.
	1/64	.015625	.3969
1/32		.03125	.7937
	3/64	.046875	1.1906
1/16		.0625	1.5875
	5/64	.078125	1.9844
	3/32	.09375	2.3812
	7/64	.109375	2.7781
1/8		.125	3.1750
	9/64	.140625	3.5719
	5/32	.15625	3.9687
	11/64	.171875	4.3656
3/16		.1875	4.7625
	13/64	.203125	5.1594
	7/32	.21875	5.5562
	15/64	.234375	5.9531
1/4		.25	6.3500
	17/64	.265625	6.7469
	9/32	.28125	7.1437
	19/64	.296875	7.5406
5/16		.3125	7.9375
	21/64	.328125	8.3344
	11/32	.34375	8.7312
	23/64	.359375	9.1281
3/8		.375	9.5250
	25/64	.390625	9.9219
	13/32	.40625	10.3187
	27/64	.421875	10.7156
7/16		.4375	11.1125
	29/64	.453125	11.5094
	15/32	.46875	11.9062
	31/64	.484375	12.3031
1/2		.5	12.7000

Fractions		Decimals	mm.
	33/64	.515625	13.0969
	17/32	.53125	13.4937
	35/64	.546875	13.8906
9/16		.5625	14.2875
	37/64	.578125	14.6844
	19/32	.59375	15.0812
	39/64	.609375	15.4781
5/8		.625	15.8750
	41/64	.640625	16.2719
	21/32	.65625	16.6687
	43/64	.671875	17.0656
11/16		.6875	17.4625
	45/64	.703125	17.8594
	23/32	.71875	18.2562
	47/64	.734375	18.6531
3/4		.75	19.0500
	49/64	.765625	19.4469
	25/32	.78125	19.8437
	51/64	.796875	20.2406
13/16		.8125	20.6375
	53/64	.828125	21.0344
	27/32	.84375	21.4312
	55/64	.859375	21.8281
7/8		.875	22.2250
	57/64	.890625	22.6219
	29/32	.90625	23.0187
	59/64	.921875	23.4156
15/16		.9375	23.8125
	61/64	.953125	24.2094
	31/32	.96875	24.6062
	63/64	.984375	25.0031
1		1.0	25.4000

MILLIMETRES TO INCHES—UNITS

mm.	0	10	20	30	40
0		.39370	.78740	1.18110	1.57480
1	.03937	.43307	.82677	1.22047	1.61417
2	.07874	.47244	.86614	1.25984	1.65354
3	.11811	.51181	.90551	1.29921	1.69291
4	.15748	.55118	.94488	1.33858	1.73228
5	.19685	.59055	.98425	1.37795	1.77165
6	.23622	.62992	1.02362	1.41732	1.81103
7	.27559	.66929	1.06299	1.45669	1.85040
8	.31496	.70866	1.10236	1.49606	1.88977
9	.35433	.74803	1.14173	1.53543	1.92914

mm.	50	60	70	80	90
0	1.96851	2.36221	2.75591	3.14961	3.54331
1	2.00788	2.40158	2.79528	3.18891	3.58268
2	2.04725	2.44095	2.83465	3.22835	3.62205
3	2.08662	2.48032	2.87402	3.26772	3.66142
4	2.12599	2.51969	2.91339	3.30709	3.70079
5	2.16536	2.55906	2.95276	3.34646	3.74016
6	2.20473	2.59843	2.99213	3.38583	3.77953
7	2.24410	2.63780	3.03150	3.42520	3.81890
8	2.28347	2.67717	3.07087	3.46457	3.85827
9	2.32284	2.71654	3.11024	3.50394	3.89764

MILLIMETRES TO INCHES—FRACTIONS

1/1000	
mm.	inches
0.001	.000039
0.002	.000079
0.003	.000118
0.004	.000157
0.005	.000197
0.006	.000236
0.007	.000276
0.008	.000315
0.009	.000354

1/100	
mm.	inches
0.01	.00039
0.02	.00079
0.03	.00118
0.04	.00157
0.05	.00197
0.06	.00236
0.07	.00276
0.08	.00315
0.09	.00354

1/10	
mm.	inches
0.1	.00394
0.2	.00787
0.3	.01181
0.4	.01575
0.5	.01969
0.6	.02362
0.7	.02756
0.8	.03150
0.9	.03543

CONVERSION TABLES

CT

DRILL SIZES

Letter	Size	Letter	Size
A	.234	N	.302
B	.238	O	.316
C	.242	P	.323
D	.246	Q	.332
E	.250	R	.339
F	.257	S	.348
G	.261	T	.358
H	.266	U	.368
I	.272	V	.377
J	.277	W	.386
K	.281	X	.397
L	.290	Y	.404
M	.295	Z	.413

Number	Size	Number	Size	Number	Size	Number	Size
1	.2280	14	.1820	27	.1440	40	.0980
2	.2210	15	.1800	28	.1405	41	.0960
3	.2130	16	.1770	29	.1360	42	.0935
4	.2090	17	.1730	30	.1285	43	.0890
5	.2055	18	.1695	31	.1200	44	.0860
6	.2040	19	.1660	32	.1160	45	.0820
7	.2010	20	.1610	33	.1130	46	.0810
8	.1990	21	.1590	34	.1110	47	.0785
9	.1960	22	.1570	35	.1100	48	.0760
10	.1935	23	.1540	36	.1065	49	.0730
11	.1910	24	.1520	37	.1040	50	.0700
12	.1890	25	.1495	38	.1015	51	.0670
13	.1850	26	.1470	39	.0995	52	.0635

WIRE GAUGES

No. of Gauge	Imperial Standard Wire Gauge		Brown and Sharpe's American Wire Gauge	
	Inches	Millimetres	Inches	Millimetres
0000	.400	10.160	.460	11.684
000	.372	9.448	.410	10.404
00	.348	8.839	.365	9.265
0	.324	8.299	.325	8.251
1	.300	7.620	.289	7.348
2	.276	7.010	.258	6.543
3	.252	6.400	.229	5.827
4	.232	5.892	.204	5.189
5	.212	5.384	.182	4.621
6	.192	4.676	.162	4.115
7	.176	4.470	.144	3.664
8	.160	4.064	.128	3.263
9	.144	3.657	.114	2.906
10	.128	3.251	.102	2.588
11	.116	2.946	.091	2.304
12	.104	2.641	.081	2.052
13	.092	2.336	.072	1.827
14	.080	2.032	.064	1.627
15	.072	1.828	.057	1.449
16	.064	1.625	.051	1.290
17	.056	1.422	.045	1.149
18	.048	1.219	.040	1.009
19	.040	1.016	.035	.911
20	.036	.914	.032	.811
21	.032	.812	.028	.722
22	.028	.711	.025	.643
23	.024	.609	.023	.573
24	.022	.558	.020	.511
25	.020	.508	.018	.454
26	.018	.457	.016	.404
27	.0164	.416	.014	.360
28	.0148	.375	.012	.321
29	.0136	.345	.011	.285
30	.0124	.314	.010	.254

CONVERSION TABLES

FOOT POUNDS TO KILOGRAMMETRES

	0	1	2	3	4	5	6	7	8	9	
—		0.138	0.227	0.415	0.553	0.691	0.830	0.968	1.106	1.244	—
10	1.383	1.521	1.659	1.797	1.936	2.074	2.212	2.350	2.489	2.627	10
20	2.765	2.903	3.042	3.180	3.318	3.456	3.595	3.733	3.871	4.009	20
30	4.148	4.286	4.424	4.562	4.701	4.839	4.977	5.116	5.254	5.392	30
40	5.530	5.668	5.807	5.945	6.083	6.221	6.360	6.498	6.636	6.774	40
50	6.913	7.051	7.189	7.328	7.466	7.604	7.742	7.881	8.019	8.157	50
60	8.295	8.434	8.572	8.710	8.848	8.987	9.125	9.263	9.401	9.540	60
70	9.678	9.816	9.954	10.093	10.231	10.369	10.507	10.646	10.784	10.922	70
80	11.060	11.199	11.337	11.475	11.613	11.752	11.890	12.028	12.166	12.305	80
90	12.443	12.581	12.719	12.858	12.996	13.134	13.272	13.411	13.549	13.687	90

MILES TO KILOMETRES

	0	1	2	3	4	5	6	7	8	9	
—		1.609	3.219	4.828	6.437	8.047	9.656	11.265	12.875	14.484	—
10	16.093	17.703	19.312	20.922	22.531	24.140	25.750	27.359	28.968	30.578	10
20	32.187	33.796	35.406	37.015	38.624	40.234	41.843	43.452	45.062	46.671	20
30	48.280	49.890	51.499	53.108	54.718	56.327	57.936	59.546	61.155	62.765	30
40	64.374	65.983	67.593	69.202	70.811	72.421	74.030	75.639	77.249	78.858	40
50	80.467	82.077	83.686	85.295	86.905	88.514	90.123	91.733	93.342	94.951	50
60	96.561	98.170	99.780	101.389	102.998	104.608	106.217	107.826	109.436	111.045	60
70	112.654	114.264	115.873	117.482	119.092	120.701	122.310	123.920	125.529	127.138	70
80	128.748	130.357	131.967	133.576	135.185	136.795	138.404	140.013	141.623	143.232	80
90	144.841	146.451	148.060	149.669	151.279	152.888	154.497	156.107	157.716	159.325	90

POUNDS TO KILOGRAMS

	0	1	2	3	4	5	6	7	8	9	
—		0.454	0.907	1.361	1.814	2.268	2.722	3.175	3.629	4.082	—
10	4.536	4.990	5.443	5.987	6.350	6.804	7.257	7.711	8.165	8.618	10
20	9.072	9.525	9.979	10.433	10.886	11.340	11.793	12.247	12.701	13.154	20
30	13.608	14.061	14.515	14.968	15.422	15.876	16.329	16.783	17.237	17.690	30
40	18.144	18.597	19.051	19.504	19.958	20.412	20.865	21.319	21.772	22.226	40
50	22.680	23.133	23.587	24.040	24.494	24.948	25.401	25.855	26.308	26.762	50
60	27.216	27.669	28.123	28.576	29.030	29.484	29.937	30.391	30.844	31.298	60
70	31.751	32.205	32.659	33.112	33.566	34.019	34.473	34.927	35.380	35.834	70
80	36.287	36.741	37.195	37.648	38.102	38.555	39.009	39.463	39.916	40.370	80
90	40.823	41.277	41.731	42.184	42.638	43.091	43.545	43.998	44.452	44.906	90

MILES PER GALLON (IMPERIAL) TO LITRES PER 100 KILOMETRES

10	28.25	15	18.83	20	14.12	25	11.30	30	9.42	35	8.07	40	7.06	50	5.65	60	4.71	70	4.04
10½	26.90	15½	18.22	20½	13.78	25½	11.08	30½	9.26	35½	7.96	41	6.89	51	5.54	61	4.63	71	3.98
11	25.68	16	17.66	21	13.45	26	10.87	31	9.11	36	7.85	42	6.73	52	5.43	62	4.55	72	3.92
11½	24.56	16½	17.12	21½	13.14	26½	10.66	31½	8.97	36½	7.74	43	6.57	53	5.33	63	4.48	73	3.87
12	23.54	17	16.61	22	12.84	27	10.46	32	8.83	37	7.63	44	6.42	54	5.23	64	4.41	74	3.82
12½	22.60	17½	16.14	22½	12.55	27½	10.27	32½	8.69	37½	7.53	45	6.28	55	5.13	65	4.35	75	3.77
13	21.73	18	15.69	23	12.28	28	10.09	33	8.56	38	7.43	46	6.14	56	5.04	66	4.28	76	3.72
13½	20.92	18½	15.27	23½	12.02	28½	9.91	33½	8.43	38½	7.34	47	6.01	57	4.96	67	4.22	77	3.67
14	20.18	19	14.87	24	11.77	29	9.74	34	8.31	39	7.24	48	5.89	58	4.87	68	4.16	78	3.62
14½	19.48	19½	14.49	24½	11.53	29½	9.58	34½	8.19	39½	7.15	49	5.77	59	4.79	69	4.10	79	3.57

CONVERSION TABLES

CT

PINTS TO LITRES

	0	1	2	3	4	5	6	7	8
—	—	.568	1.136	1.705	2.273	2.841	3.411	3.978	4.546
10	.142	.710	1.279	1.846	2.415	2.983	3.552	4.120	4.688
20	.284	.852	1.420	1.989	2.557	3.125	3.694	4.262	4.830
30	.426	.994	1.563	2.131	2.699	3.267	3.836	4.404	4.972

GALLONS (IMPERIAL) TO LITRES

	0	1	2	3	4	5	6	7	8	9	
—	—	4.546	9.092	13.638	18.184	22.730	27.276	31.822	36.368	40.914	—
10	45.460	50.005	54.551	59.097	63.643	68.189	72.735	77.281	81.827	86.373	10
20	90.919	95.465	100.011	104.557	109.103	113.649	118.195	122.741	127.287	131.833	20
30	136.379	140.924	145.470	150.016	154.562	159.108	163.654	168.200	172.746	177.292	30
40	181.838	186.384	190.930	195.476	200.022	204.568	209.114	213.660	218.206	222.752	40
50	227.298	231.843	236.389	240.935	245.481	250.027	254.473	259.119	263.605	268.211	50
60	272.757	277.303	281.849	286.395	290.941	295.487	300.033	304.579	309.125	313.671	60
70	318.217	322.762	327.308	331.854	336.400	340.946	345.492	350.038	354.584	359.130	70
80	363.676	368.222	372.768	377.314	381.860	386.406	390.952	395.498	400.044	404.590	80
90	409.136	413.681	418.227	422.773	427.319	431.865	436.411	440.957	445.503	450.049	90

POUNDS PER SQUARE INCH TO
KILOGRAMS PER SQUARE CENTIMETRE

	0	1	2	3	4	5	6	7	8	9	
—	—	0.070	0.141	0.211	0.281	0.352	0.422	0.492	0.562	0.633	—
10	0.703	0.773	0.844	0.914	0.984	1.055	1.125	1.195	1.266	1.336	10
20	1.406	1.476	1.547	1.617	1.687	1.758	1.828	1.898	1.969	2.039	20
30	2.109	2.179	2.250	2.320	2.390	2.461	2.531	2.601	2.672	2.742	30
40	2.812	2.883	2.953	3.023	3.093	3.164	3.234	3.304	3.375	3.445	40
50	3.515	3.586	3.656	3.726	3.797	3.867	3.937	4.007	4.078	4.148	50
60	4.218	4.289	4.359	4.429	4.500	4.570	4.640	4.711	4.781	4.851	60
70	4.921	4.992	5.062	5.132	5.203	5.273	5.343	5.414	5.484	5.554	70
80	5.624	5.695	5.765	5.835	5.906	5.976	6.046	6.117	6.187	6.257	80
90	6.328	6.398	6.468	6.538	6.609	6.679	6.749	6.820	6.890	6.960	90

U.N.E.F. SCREW THREADS

Dia.	No. of thds.	Core dia.	Tap drill	Dia.	No. of thds.	Core dia.	Tap drill
1/4 in.	32	.2162 in.	5-60 mm.	1 in.	20	.9459 in.	61/64 in.
5/16 in.	32	.2787 in.	7-20 mm.	1-1/16 in.	18	1.0024 in.	1-010 in.
3/8 in.	32	.3412 in.	11/32 ins	1-1/8 in.	18	1.0649 in.	1-072 ins.
7/16 in.	28	.3988 in.	10-20 mm.	1-3/16 in.	18	1.1274 in.	1-135 in.
1/2 in.	28	.4613 in.	11-80 mm.	1-1/4 in.	18	1.1899 in.	1-196 in.
9/16 in.	24	.5174 in.	13-30 mm.	1-5/16 in.	18	1.2524 in.	32-00 mm.
5/8 in.	24	.5799 in.	14-75 mm.	1-3/8 in.	18	1.3149 in.	33-50 mm.
11/16 in.	24	.6424 in.	.6480 in.	1-7/16 in.	18	1.3774 in.	1-385 ins.
3/4 in.	20	.6959 in.	45/64 in.	1-1/2 in.	18	1.4399 in.	1-447 in.
13/16 in.	20	.7584 in.	49/64 in.	1-9/16 in.	18	1.4948 in.	1-1/2 in.
7/8 in.	20	.8209 in.	53/64 in.	1-5/8 in.	18	1.5649 in.	1-572 in.
15/16 in.	20	.8834 in.	57/64 in.	1-11/16 in.	18	1.6274 in.	41-50 mm.

B.A. SCREW THREADS

No.	Dia. of bolt	Thds. per inch	Dia. tap drill	Core dia.
0	.2362	25-4	.1960	.1890
1	.2087	28-2	.1770	.1661
2	.1850	31-4	.1520	.1468
3	.1614	34-8	.1360	.1269
4	.1417	38-5	.1160	.1106
5	.1260	43-0	.1040	.0981
6	.1102	47-9	.0935	.0852
7	.0984	52-9	.0810	.0738
8	.0866	59-1	.0730	.0663
9	.0748	65-1	.0635	.0564
10	.0669	72-6	.0550	.0504
11	.0591	81-9	.0465	.0445
12	.0511	90-9	.0400	.0378
13	.0472	102-0	.0360	.0352
14	.0394	109-9	.0292	.0280
15	.0354	120-5	.0260	.0250
16	.0311	133-3	.0225	.0220

CONVERSION TABLES

CT

B.S.W. SCREW THREADS

Dia. of bolt (inch)	Threads per inch	Dia. tap drill (inch)	Core dia.
1/4	20	.1968	.1860
5/16	18	1/4	.2412
3/8	16	5/16	.2950
7/16	14	23/64	.3460
1/2	12	13/32	.3933
9/16	12	15/32	.4558
5/8	11	17/32	.5086
11/16	11	37/64	.5711
3/4	10	41/64	.6219
13/16	10	45/64	.6844
7/8	9	3/4	.7327
15/16	9	13/16	.7952
1	8	55/64	.8399

B.S.F. SCREW THREADS

Dia. of bolt (inch)	Threads per inch	Dia. tap drill (inch)	Core dia.
7/32	28	.1770	.1731
1/4	26	.2055	.2007
9/32	26	.238	.2320
5/16	22	.261	.2543
3/8	20	.316	.3110
7/16	18	3/8	.3664
1/2	16	27/64	.4200
9/16	16	.492	.4825
5/8	14	35/64	.5335
11/16	14	39/64	.5960
3/4	12	21/32	.6433
13/16	12	23/32	.7058
7/8	11	25/32	.7586
1	10	57/64	.8719
1-1/8	9	1	.9827
1-1/4	9	1-1/8	1.1077
1-3/8	8	1-15/64	1.2149
1-1/2	8	1.358	1.3399
1-5/8	8	1-31/64	1.4649

U.N.C. SCREW THREADS

Dia.	No. of thds.	Core dia.	Tap drill
1/4 in.	20	.1959 in.	5-20 mm.
5/16 in.	18	.2524 in.	6-60 mm.
3/8 in.	16	.3073 in.	8-00 mm.
7/16 in.	14	.3602 in.	9-40 mm.
1/2 in.	13	.4167 in.	10-80 mm.
9/16 in.	12	.4723 in.	12-20 mm.
5/8 in.	11	.5266 in.	13-50 mm.
3/4 in.	10	.6417 in.	16-50 mm.
7/8 in.	9	.7547 in.	49/64 in.
1 in.	8	.8647 in.	22-25 mm.
1-1/8 in.	7	.9704 in.	63/64 in.
1-1/4 in.	7	1.0954 in.	1-7/64 in.
1-3/8 in.	6	1.1946 in.	1-13/64 in.
1-1/2 in.	6	1.3196 in.	1-21/64 in.
1-3/4 in.	5	1.5335 in.	1-35/64 in.
2 in.	4-1/2	1.7594 in.	1-25/32 in.

U.N.F. SCREW THREADS

Dia.	No. of thds.	Core dia.	Tap drill
1/4 in.	28	.2113 in.	5-50 mm.
5/16 in.	24	.2674 in.	6-90 mm.
3/8 in.	24	.3299 in.	8-50 mm.
7/16 in.	20	.3834 in.	9-90 mm.
1/2 in.	20	.4459 in.	11-50 mm.
9/16 in.	18	.5024 in.	12-90 mm.
5/8 in.	18	.5649 in.	14-50 mm.
3/4 in.	16	.6823 in.	11/16 in.
7/8 in.	14	.7977 in.	0-804 in.
1 in.	12	.9098 in.	23-25 mm.
1-1/8 in.	12	1.0348 in.	26-50 mm.
1-1/4 in.	12	1.1598 in.	29-50 mm.
1-3/8 in.	12	1.2848 in.	1-290 in.
1-1/2 in.	12	1.4098 in.	36-00 mm.