

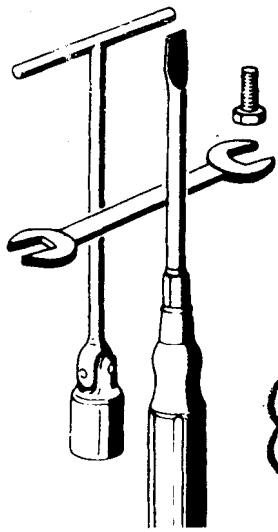

V 1000
G 5

850 Le Mans
II

WORKSHOP MANUAL



1000 SP

850-T3

ADDITIONS AND CHANGES FOR 850-T 3 MODEL

INTRODUCTION

Purpose of this manual is to give the necessary instructions for overhauling and carrying out repairs in a rational way.

All data herein contained are meant to give a general knowledge of the main checking operations to be done when overhauling the different component groups.

To this end, the manual contains many illustrations, drawings, diagrams, and tables to assist you in the stripping, checking, and assembling operations.

This manual will also be a guidance for anybody who wishes to familiarize with the manufacturing characteristics of the various component parts of the **V 1000 G 5** and **1000 SP** models.

The knowledge of these will be an essential factor for performing a good job.

All illustrations and descriptions in this manual should be intended as indicative only as the Manufacturer reserves itself the right to introduce at any time and without prior advice any modification it may deem useful for a better performance or for any other reason of a constructional or commercial nature.

NOTE The terms «right» and «left» in the text are to be considered as seen by the rider astride the machine.

INDEX

1

IDENTIFICATION DATA

- 1.1 Spare parts
- 1.2 Warranty

2

MODEL IDENTIFICATION

- 2.1 Model V 1000 G 5
- 2.2 Model 1000 SP

3

CONTROLS AND ACCESSORIES

- 3.1 Model V 1000 G 5
- 3.2 Model 1000 SP

4

LUBRICATION

- 4.1 Engine lubrication
- 4.2 Replacing the oil filter cartridge and cleaning the wire gauze filter
- 4.3 Lubricating the gearbox
- 4.4 Lubricating the rear drive box
- 4.5 Fork lubrication
- 4.6 Lubrication of steering bearings and swing arm

5

INSTRUMENTS AND CONTROLS

- 5.1 Panel board - model V 1000 G 5
- 5.2 Ignition key - model V 1000 G 5
- 5.3 Panel board - model 1000 SP
- 5.4 Light switches
- 5.5 Horn, turn lights and flashing light buttons
- 5.6 Engine starting and emergency stop button
- 5.7 Easy starter lever

- 5.8 Throttle control grip
- 5.9 Clutch control lever
- 5.10 Right front brake control lever
- 5.11 Twin brake control, front left and rear
- 5.12 Gearshift pedal
- 5.13 Fuel filler cap
- 5.14 Fuel level
- 5.15 Fuel tap - V 1000 G 5 model
- 5.16 Fuel tap - V 1000 SP model
- 5.17 Electrovalve - V 1000 G 5
- 5.18 Terminal block with fuses
- 5.19 Steering lock
- 5.20 Side stand - V 1000 G 5 model
- 5.21 Side stand - 1000 SP model
- 5.22 Steering damper - 1000 SP model

6 MAINTENANCE AND ADJUSTMENTS

- 6.1 Adjusting the clutch lever play
- 6.2 Adjusting the right front brake lever
- 6.3 Adjusting the front left and rear brake pedal
- 6.5 Adjusting the steering
- 6.4 Adjusting the rear suspension
- 6.6 Adjusting the throttle control grip
- 6.7 Adjusting the rear wheel spokes - V 1000 G 5
- 6.8 Adjusting the headlight beam - V 1000 G 5
- 6.9 Adjusting the headlight beam - 1000 SP
- 6.10 Rocker clearance
- 6.11 Adjusting the double contact breaker
- 6.12 Maintenance
- 6.13 Cleaning the windshield

7 LUBRICATION AND MAINTENANCE CHECKS

8 TORQUE WRENCH SETTINGS

9 SPECIAL TOOLS FOR REPAIR SHOPS

10 REMOVING THE ENGINE GEARBOX UNIT FROM THE FRAME

- 10.1 Introduction
- 10.2 Removal

11 STRIPPING THE ENGINE

12 OVERHAULING AND CHECKING OPERATIONS

- 12.1 Rocker covers
- 12.2 Stripping the cylinder heads
- 12.3 Cylinder heads
- 12.4 Valve guides

- 12.5 Valve seats
- 12.6 Valves
- 12.7 Checking the inlet and exhaust valve opening
- 12.8 Inspecting the valve springs
- 12.9 Refitting the valve springs assembly on heads
- 12.10 Assembling the cylinder barrels
- 12.11 Refitting the cylinder heads on the cylinders
- 12.12 Cylinder barrels
- 12.13 Pistons
- 12.14 Piston rings and oil scraper
- 12.15 Connecting rods
- 12.16 Fitting the con-rods on crankshaft
- 12.17 Crankshaft
- 12.18 Checking the weight for engine balancing
- 12.19 Fitting the flywheel on the crankshaft
- 12.20 Drive side flange complete with main journal
- 12.21 Seal for flange, drive side
- 12.22 Fitting the flange c/w journal in crankcase, drive side
- 12.23 Assembling the seal on timing cover
- 12.24 Crankcase
- 12.25 Checking oil leakages from the crankcase

13

TIMING

pag. 56

- 13.1 Timing data
- 13.2 Diameter of camshaft bearings in their housings in crankcase
- 13.3 Tappet-guide in crankcase - coupling data
- 13.4 Assembling the crankshaft assembly, gears with chain on shaft, engine-timing, oil pump
- 13.5 How to change the chain and/or gear with engine assembled on the frame
- 13.6 Valve timing

14

ENGINE LUBRICATION

pag. 60

- 14.1 Oil deliver pump
- 14.2 Oil sump
- 14.3 Replacing the oil filter cartridge
- 14.4 Wire gauze filter
- 14.5 Oil pressure relief valve
- 14.6 Oil breather valve on the crankcase piping to the re-cycling device on filter ass.y
- 14.7 Oil pressure solenoid
- 14.8 Checking the oil pressure with engine on the byke

15

CARBURATION

pag. 64

- 15.1 Carburettors
- 15.2 Float levelling
- 15.3 Adjusting the carburation and idling speed

- 15.4 Checking carburation with a vacuumeter
- 15.5 Carburettor components
- 15.6 Replacing the air filter cartridge on assembled engine

16

pag. 68

- 16.1 Removing the clutch assembly
- 16.2 Inspections
- 16.3 Assembling the clutch on flywheel

17

pag. 70

- 17.1 Stripping the gearbox
- 17.2 Checking and overhauling the gearbox components
- 17.3 Assembling the gearbox on the bench

18

pag. 80

- 18.1 Removing the gear drive box
- 18.2 Inspections and overhauls
- 18.3 Re-assembly

19

pag. 84

20

pag. 90

21

pag. 98

22

pag. 103

- 22.1 Inspection
- 22.2 Removing the bearings from the swing fork
- 22.3 Pressing the outer races on the swing arm taper bearings
- 22.4 Pressing the bearings into the R/H arm of the swing fork
- 22.5 Adjusting the swing arm play

23

pag. 105

- 23.1 Removing the front wheel - V 1000 G 5 model
- 23.2 Removing the front wheel - 1000 SP model
- 23.3 Rear wheel - V 1000 G 5 model
- 23.4 Rear wheel - 1000 SP model
- 23.5 Tires
- 23.6 Tensioning the wheel spokes - V 100 G 5
- 23.7 Wheel balancing
- 23.8 Tire removal and refitting - V 1000 G 5
- 23.9 Tire removal and refitting - 1000 SP
- 23.10 Checking and overhauling the braking circuits
- 23.11 Master cylinder for right front brake

- 23.12 Master cylinder for left front and rear brakes
- 23.13 Brake caliper for front brakes (model V 1000 G 5) and rear brakes (model 1000 SP)
- 23.14 Front brake caliper for 1000 SP model
- 23.15 Brake pads
- 23.16 Pipes
- 23.17 Braking discs
- 23.18 Braking circuit faults
- 23.19 Recommendations

24

- 24.1 Battery
- 24.2 Alternator-generator
- 24.3 Regulator
- 24.4 Rectifier
- 24.5 Starter motor
- 24.6 Ignition system
- 24.7 Automatic advance
- 24.8 Capacitors
- 24.9 Ignition coils
- 24.10 Spark plugs
- 24.11 Twin contact breaker
- 24.12 Assembling the breaker on the crankcase
- 24.13 Ignition timing
- 24.14 Checking the ignition advance (static + dynamic) using a strobe lamp
- 24.15 Lighting equipment and horns - V 1000 G 5
- 24.16 Lighting equipment and horns - 1000 SP

25

- 25.1 Legend - V 1000 G 5 model
- 25.2 Legend - 1000 SP model



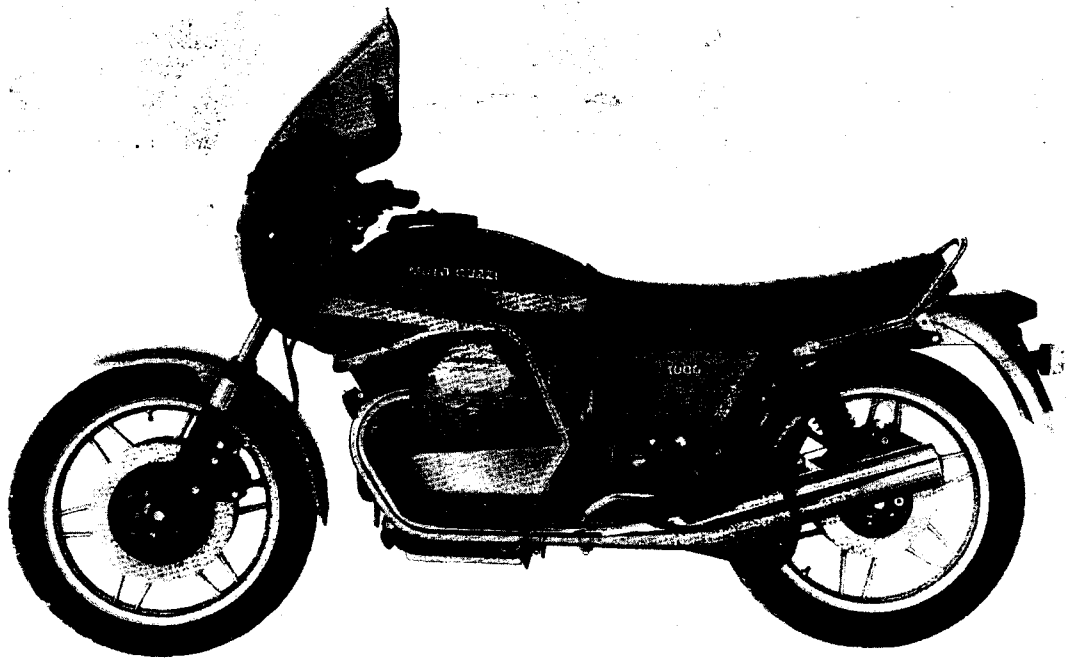
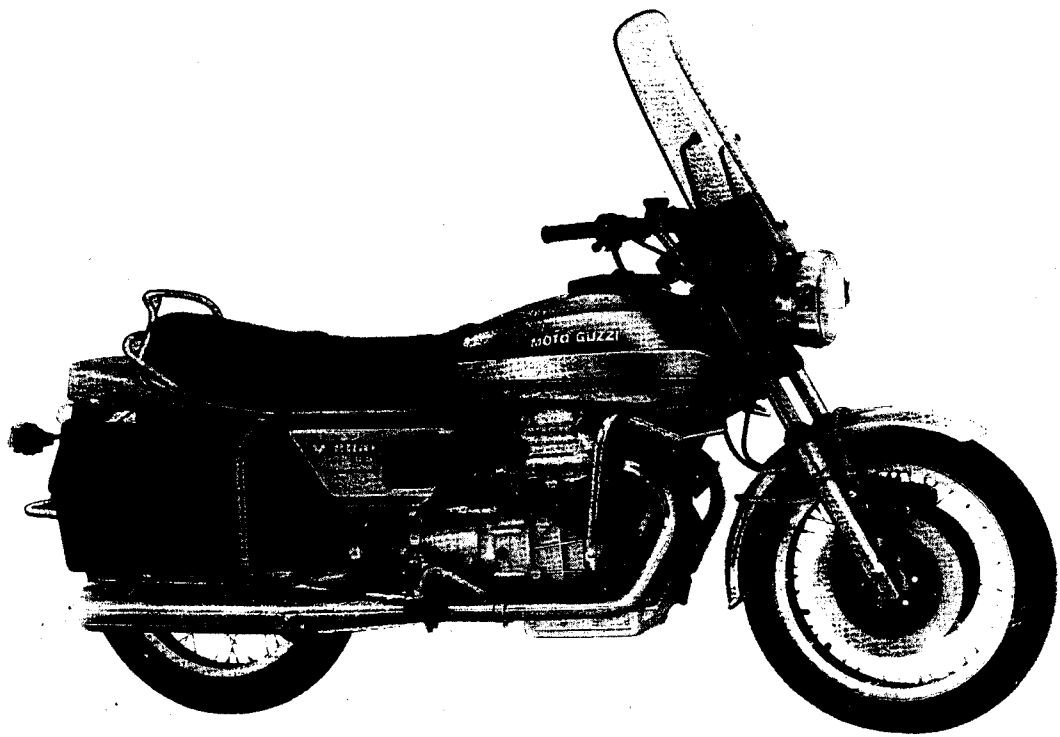

1 IDENTIFICATION DATA

(fig. 1)

Every motorcycle is identified by an identification plate located on the frame downtube and a serial number stamped on the engine crankcase. The identification plate number is also mentioned in the motorcycle logbook and identifies the vehicle to all legal effects.

1.1 SPARE PARTS

In case of any replacements, ensure that «Original Moto Guzzi Spare parts» only are used. The use of non-genuine parts invalidates every warranty right.

1.2 WARRANTY

The warranty is valid for a period of 6 months with a limitation to 10.000 k.m. (6000 miles) from the selling date and expires in case of modifications to the motorcycle or participation to racing competitions.

Tyres as well as parts or accessories which are not manufactured in the SEIMM MOTO GUZZI factories are excluded from this warranty.

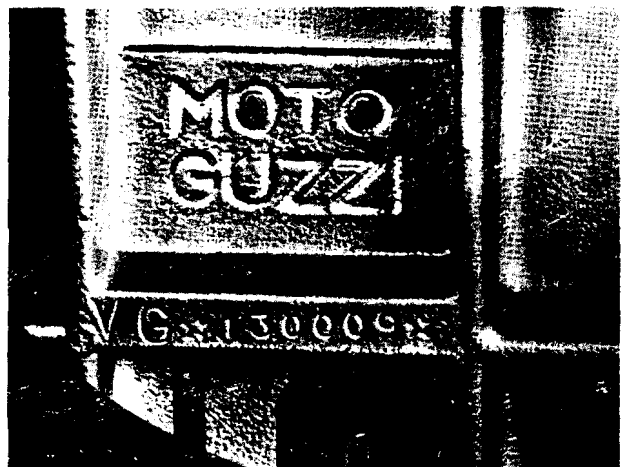
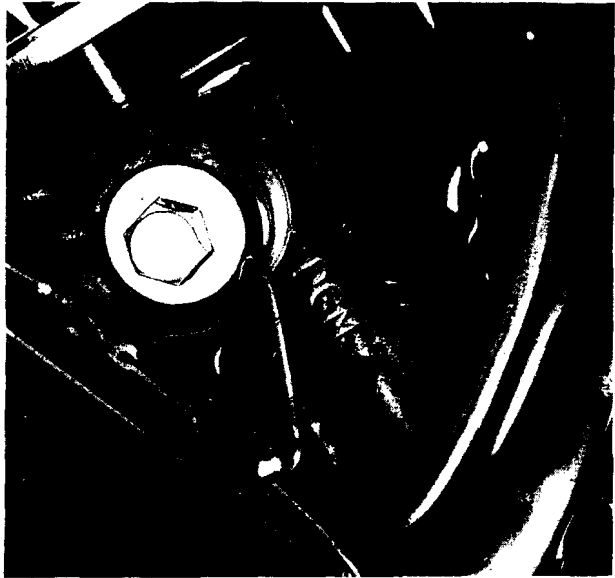

2 MAIN FEATURES

2.1 MODEL V 1000 G 5

Engine	2-cylinder, 4-stroke
	Cylinder disposition «V», 90°
	Bore 88 mm
	Stroke 78 mm
	Displacement 948.8 cc
	Compression ratio 9.2 to 1
	Max torque 8.6 kgm at 5200 rpm
Valve gearing	OHV, push rod operated
Carburation	2 Dell'Orto carburetors VHB 30 CD (right), VHB 30 CS (left).
Lubrication	Pressure, by gear pump. Wire gauze and cartridge filters in oil sump. Normal lubrication pressure 3.8 ÷ 4.2 kg/sqcm (54-60 p.s.i.). Controlled by pressure relief valve.
Generator-alternator	Front, on crankshaft (14 V-20 A).
Ignition	Battery-coil ignition with twin contact breaker and automatic advance. Ignition data: <ul style="list-style-type: none">■ initial advance (fixed) 2°■ automatic advance 31°■ full advance (f. + a.) 33° Contact points gap: 0.37 ÷ 0.43 mm (.014-.016). Spark plugs: AC - 44 XL Bosch W 225 2 T Champion N 9 Y Lodge H L N Y Marelli CW 7 LP Plug points gap: 0.6 mm (.023") 2 ignition coils
Starting	Electric starter (12 V-0.7 KW) with electromagnetic ratchet control. Ring gear bolted on the flywheel. Starter button (START) on the right side of the handlebar.

TRANSMISSIONS

Clutch	Dry type, twin plates. Hand controlled by lever on the left side of the handlebar.
Primary drive	By gears. Ratio: 1.235 (Z = 17/21)

Gear box

Five-speeds. Constant mesh gear with frontal engagement incorporating cush drive.

Pedal controlled from the L/H side of the vehicle. Gear ratios:

1st gear = 1 : 2 (14/28)

2nd gear = 1 : 1.388 (18/25)

3rd gear = 1 : 1.047 (21/22)

4th gear = 1 : 0.869 (23/20)

High gear = 1 : 0.750 (28/21)

Secondary drive

By cardan shaft and bevel gear set.

Ratio: 1 : 4.714 (7/33)

Overall ratios (engine-rear wheel)

1st gear = 1 : 11.643

2nd gear = 1 : 8.080

3rd gear = 1 : 6.095

4th gear = 1 : 5.059

High gear = 1 : 4.366

FRAME

Duplex cradle, tubular structure.

Wheels

Spoked rims, WM 3/2.15 - 18"

Tyres

Front: 100/90 H 18 (MT 18)

Rear: 110/90 H 18 (MT 18)

Tyre pressure:

Front, solo riding or with pillion 2.1 kg/cm² (30 lbs s.i.).

Rear, solo riding 2.4 kg/cm² (34 p.s.i.)
with pillion 2.6 kg/cm² (37 p.s.i.).

The above figures apply for normal riding (cruising). If using the motorcycle at constant high speed or on highways, it is recommended to increase pressure by 0.2 kg/cm² (3 p.s.i.).

Brakes

Front: twin disc brake, fixed caliper with two cylinders. Hand controlled by lever on the right hand side of the handlebar. Braking circuit independent from rear brake.

Disc Ø 300 mm (11.8").

Cylinder dia. 38 mm (1.49").

Master cylinder dia. 12.7 mm (.5").

Rear: Disc brake, foot controlled from the right side of the motorcycle. Double cylinder caliper and hydraulic hose.

Disc dia. 242 mm (9.52").

Cylinder dia. 48 mm (1.49").

Master cylinder dia. 15.857 mm (.63").

The rear brake is hydraulically connected to a second front brake of same type and sizes as the hand operated front brake.

Dimensions and weights

Wheelbase 1.470 m (58")

Length 2.200 m (86.5")

Width 0.850 m (33")

Height 1.100 m (46")

Ground clearance 0.175 m (6.9")

Ground clearance 0.175 m (6.8")

Dry weight abt. 220 kg (485 lbs)

Performances

Top speed, solo riding abt 190 km/h (120 m.p.h.).

Fuel consumption: 5.8 lts × 100 km (abt. 36 m.p.g.).

FUEL AND OIL CAPACITIES

Group or part	Quantity	Recommendation
Fuel tank	24 lts. (6.5 US gls.)	Petrol 98 100 NO-RM
Reserve (warned by light)	4 lts. (abt. 1 US gl.)	
Oil sump	3 lts. (abt. 3 $\frac{1}{8}$ qts US)	Oil «Agip Sint 2000 SAE 10 W 50»
Gear box	0.750 lts. (abt. 25 oz. US)	Oil «Agip F. 1 Rotra MP SAE 90»
Rear drive box (bevel gear lubrication)	0.250 lts. (8 $\frac{1}{2}$ oz.) of which 0.230 lts. (8 oz.)	Oil «Agip F. 1 Rotra MP SAE 90»
	0.020 lts. ($\frac{1}{2}$ oz.)	Agip Rocol ASO-R oil Molikote oil type A
Front fork (each leg)	0.080 lts. (2 oz.)	Agip F. 1 ATF Dexron
Braking circuits (front and rear)		Agip F. 1. Brake fluid SAE J 1703 B

2.2. MODEL 1000 SP

Engine

Two-cylinder, 4-stroke

Cylinder disposition «V», 90°

Bore 88 mm

Stroke 78 mm

Displacement 948,8 cc

Compression ratio 9.2 to 1

Max torque 8.6 kgm at 5200 r.p.m.

Valve gearing

OHV, push rod operated.

Carburation

2 Dell'Orto carburetors VHB 30 CD (right) VHB 30 CS (left).

Lubrication

Pressure, by gear pump.

Wire gauze and cartridge filters in oil sump.

Normal lubrication pressure 3.8 ÷ 4.2 kg/sqcm (54-60 p.s.i.).

Controlled by pressure relief valve.

Generator-Alternator

Front, on crankshaft (14 V - 20 A):

Ignition

Battery-coil ignition with twin contact breaker and automatic advance.

Ignition data:

- initial advance (fixed) 2°
- automatic advance 31°
- full advance 33°

Contact breaker gap: 0.37-0.43 mm (.014 ÷ .016").

Spark plugs: AC-44 XL
Bosch W 225 T 2
Marelli CW 7 LP

Champion N 9 Y
Lodge H L N Y

Plug points gap: 0.6 mm (.023")
2 ignition coils

Starting

Electric starter (12 V - 0.7 KW) with electromagnetic ratchet control.
Ring gear bolted on the flywheel.
Starter button (START) on the right side of the handlebar.

TRANSMISSION

Clutch

Dry type, twin driven plates. It is housed on the flywheel. Hand controlled by lever on the L/H side of the handlebar.

Primary drive

By gears. Ratio: 1 to 1.235 (17/21).

Gear box

5-speeds. Constant mesh gear with frontal engagement
Cush drive incorporated. Pedal controlled on the L/H side of the vehicle.

Gear ratio:

Low gear = 1 to 2 (14/18)

2nd gear = 1 to 1.388 (18/25)

3rd gear = 1 to 1.047 (21/22)

4th gear = 1 to 0.869 (23/20)

High gear = 1 to 0.750 (28/21)

Secondary drive

By cardan shaft, bevel gear set.
Ratio: 1 to 4.714 (7/33).

Overall gear ratios (engine-wheel):

Low gear = 1 to 11.643

2nd gear = 1 to 8.090

3rd gear = 1 to 6.095

4th gear = 1 to 5.059

High gear = 1 to 4.366

FRAME

Duplex cradle, tubular structure.

Wheels

Light alloy casting. Rims WM 3/2. 15-18" CP 2.

Tires

Front: 100/90 H 18 (MT 18).

Rear: 110/90 H 18 (MT 18).

Tire pressure:

Front, solo or with pillion 2.1 kg/cm² (30 p.s.i.).

Rear, solo 2.4 kg/cm² (34 p.s.i.).

with pillion 2.6 kg/cm² (37 p.s.i.).

The above data apply for normal riding (cruising speed).

If using the motorcycle at constant high speed or on high ways, the above pressure should be increased by 0.2 kg/cm² (3 p.s.i.).

Brakes

Disc type with double cylinder caliper. Lever controlled from the R/H side of the handlebar. Hydraulic circuit independent from the rear brake.

Disc dia. mm 300 (11.8").
 Cylinder dia. 38 mm (1.49").
 Master cylinder dia. 12.7 mm (.5").

Rear wheel

Disc type with double cylinder fixed caliper. Foot controlled from the R/H side of the byke.
 Rear brake and the left front brake are interconnected by a hydraulic circuit actuated by the same pedal.

Disc dia. 242 mm (9.52").
 Cylinder dia. 48 mm. (1.88").
 Master cylinder dia. 15.867 mm (.62").

The rear brake is hydraulically connected to a second front brake of same type and sizes as the hand operated front brake.

Dimensions and weights

Wheelbase (loaded) 1.480 m (58")
 Length 2.180 m (86")
 Width 0.750 m (29.5")
 Width (incl. windshield) 1.380 m (54")
 Min. ground clearance 0.175 m (6.9")
 Dry weight abt. 210 kgs. (463 lbs)

Performances

Max speed, solo riding abt. 200 km/h (125 m.p.h.).
 Fuel consumption: 5.8 lts × 100 km (36 m.p.g.).

FUEL AND OIL CAPACITIES

Group or part	Quantity	Recommendation
Fuel tank	24 lts. (6.5 US gls.)	} Petrol 98/100 NO-RM
Reserve	4 lts. (abt. 1 US gl.)	
Oil sump	3 lts. (abt. 3 1/8 qts. USA)	Oil Agip SINT 2000 SAE 10 W/50
Gear box	0.750 lts. (25 oz. US)	Oil Agip F. 1. Rotra MP SAE 90
Rear drive box	0.250 lts. (abt. 8 1/2 oz.) of dhich	Agip F. 1 Rotra MP SAE 90 Agip Rocol ASO/R oil Molikote oil type «A» Agip F. ATF Dexron
	0.230 lts. (8 oz.)	
	0.20 lts. (1/2 oz.)	
Front fork (each leg)	0.090 lts. (abt. 3 oz.)	Agip D. 1 Brake fluid SAE J 1703 B
Braking circuits (front and rear)		

3 CONTROLS AND ACCESSORIES

3.1 MODEL V 1000 G 5 (fig. 2)

- 1 Caliper, right front brake
- 2 Turn light indicator, front
- 3 Panel with warning lights
- 4 Speedometer
- 5 Reservoir (master cylinder), right front brake
- 6 Lever, right front brake
- 7 Starter and emergency stop button
- 8 Throttle control grip
- 9 Light and ignition key switch
- 10 Rev counter
- 11 Pedal, left front and rear brakes
- 12 Foot rest
- 13 Reservoir (master cylinder), left front and rear brakes
- 14 Footrest, pillion
- 15 Safety bar, rear
- 16 Saddle bag
- 17 Caliper, left front brake
- 18 Headlight
- 19 Clutch lever
- 20 Safety bar, front
- 21 Buttons controlling horn, flashing lights, and turn signal lights
- 22 Light switch
- 23 Lock, filler cap cover opening
- 24 Easy start control lever
- 25 Gear selector pedal
- 26 Caliper, rear brake
- 27 Turn signal indicator, rear

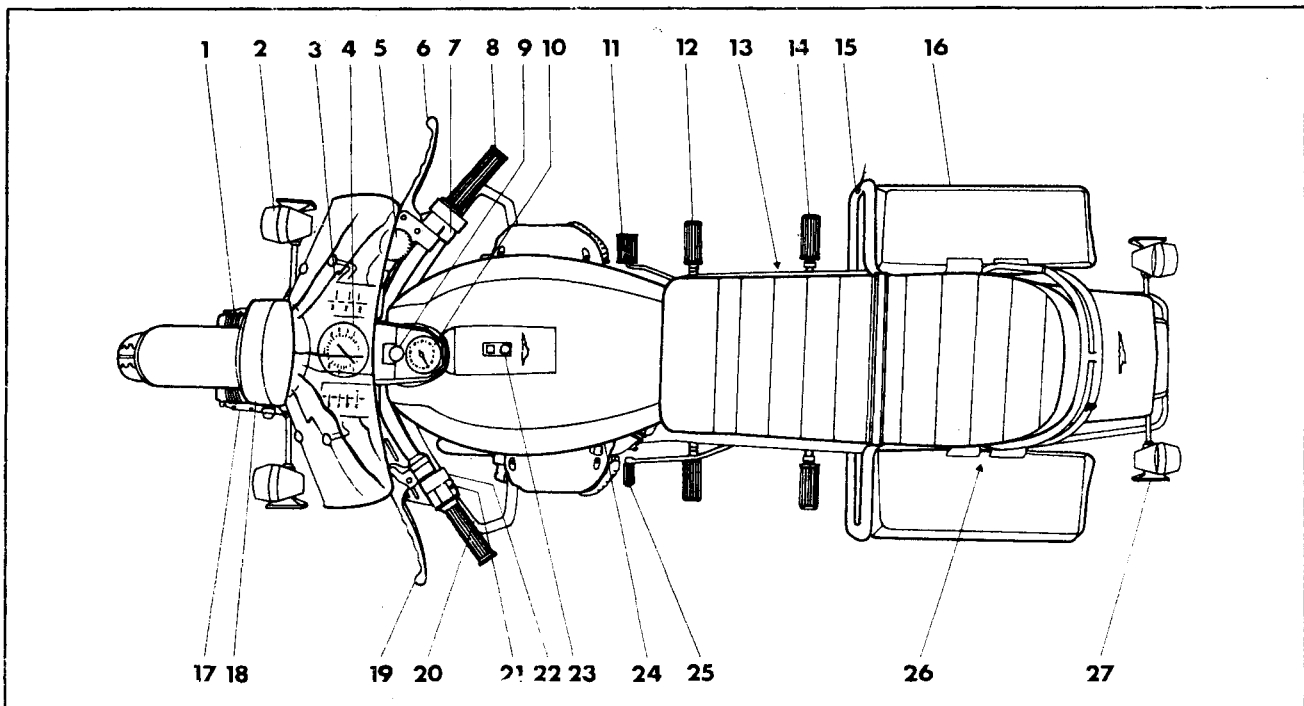

3.2 MODEL 1000 SP (fig. 3)

- 1 Caliper, right front brake
- 2 Speedometer
- 3 Voltmeter
- 4 Rear view mirror
- 5 Lever, right front brake
- 6 Throttle control grip
- 7 Start and emergency stop button
- 8 Front fairing
- 9 Pedal, left front and rear brakes
- 10 Footrest
- 11 Pillion footrest
- 12 Turn signal indicator, rear
- 13 Caliper, left front brake
- 14 Rev-counter
- 15 Clock
- 16 Windshield
- 17 Clutch lever
- 18 Control buttons (horn, flashing lights, turn signal)
- 19 Light switch
- 20 Ignition key
- 21 Lock, fuel filler cap cover
- 22 Gear selector pedal
- 23 Center stand
- 24 Tail light
- 25 Saddle release catch

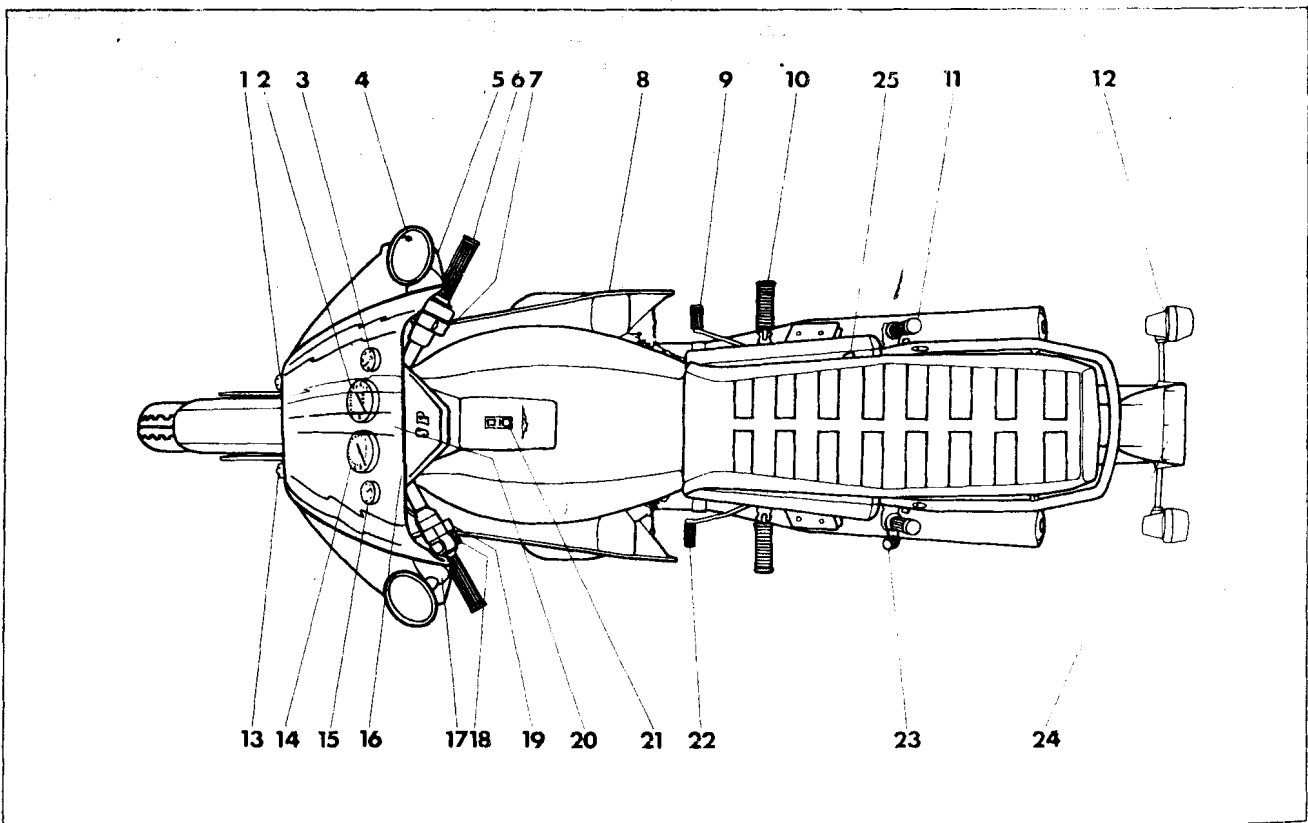

3

4 LUBRICATIONS

4.1 ENGINE LUBRICATION (fig. 4 and 4/1)

Checking the oil level

Every 500 km (300 miles) check the oil level in the crankcase.

Correct level is nearly at the top notch on the filler dipstick «A». If the oil is lower, top up with oil of the same brand and density. This check should be done after the engine has idled for a few minutes.

For model V 1000 G5 (fig. 4), filler cap with dipstick «A» has to be fully screwed down.

For model 1000 SP (fig. 4/1), filler cap with dipstick «A» has to be kept fully pressed down.

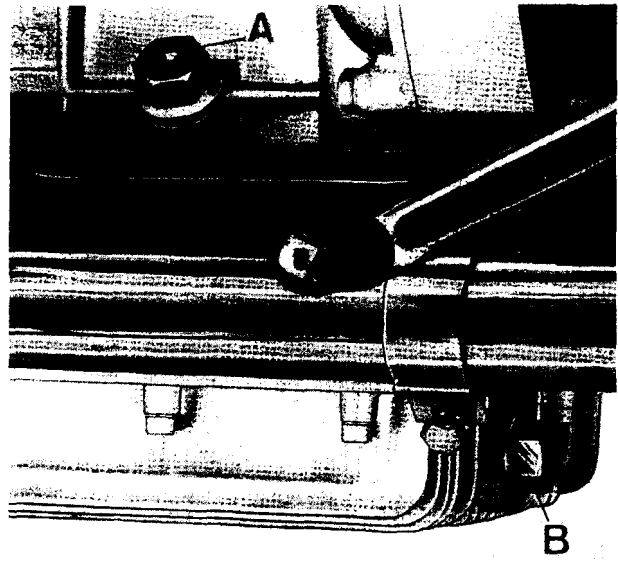

Replacing the engine oil

After the first 500 - 1000 km (300 - 600 miles) and later on every 3000 km (abt 2000 miles), replace the engine oil.

This replacement should be made on a warm engine, after draining all the old oil.

«A» = Filler cap and dipstick.

«B» = Oil drain plug (for model 1000 SP see fig. 5).

Quantity required: 3 lts. of oil AGIP Sint 2000 SAE 10W/50 (abt. 3 1/8 qts. US).

4.2 REPLACING THE OIL FILTER CARTRIDGE AND CLEANING THE WIRE GAUZE FILTER (fig. 5)

Every 15.000 km (9000 miles) that is after 5 oil changes, replace cartridge «A», proceeding as follows:

- Undo plug «B» and let the old oil drain fully.
- Undo fixing screws and remove the oil sump with filter cartridge «A», wire gauze filter «D», and oil pressure valve «E».
- Unscrew cartridge «A» and replace it with an original one.

When replacing cartridge «A» it is recommended to also remove wire gauze filter «D». Wash this in a petrol bath, drying it with a jet of compressed air. The oil passage in the sump should also be blown through with compressed air.

Do not forget to replace the sump gasket when refitting this.



4.3 LUBRICATING THE GEAR BOX (fig. 6 and 6/1)

Checking the oil level

Every 3000 km (abt. 2000 miles), check if the oil level in the box is nearly up to inspection hole «B».

If the oil is lower, top up with oil of same brand and density.

Replacing the oil

Every 10.000 km (abt. 6000 miles), the gear box oil should be replaced. This replacement has to be done

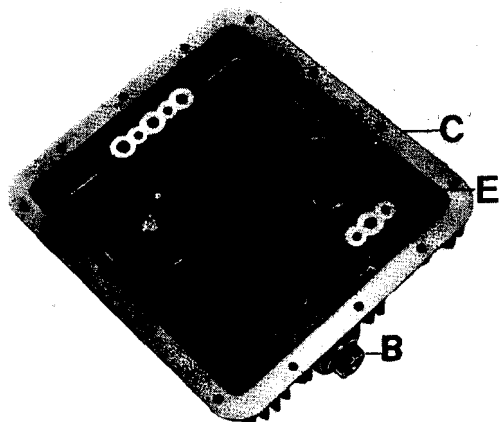

5

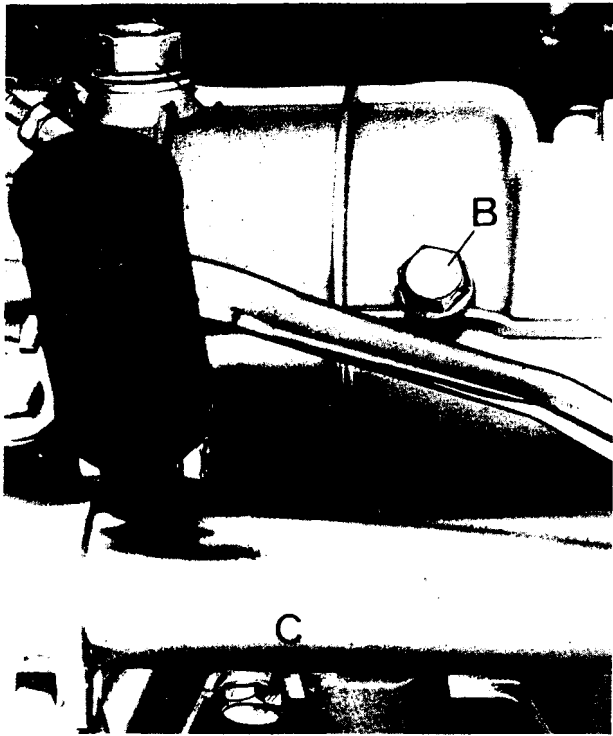

on a warm engine as in such condition the oil is fluid and more easy to drain. Do not forget to let the old oil drain fully before any fresh one is introduced.

«A» - filler cap.

«B» - inspection hole cap.

«C» - drain plug.

Quantity required: 0.750 lts. (abt. 1³/₄ pints us) AGIP F. 1 Rotra MP oil SAE 90.

4.4 LUBRICATION OF REAR DRIVE BOX (fig. 7)

Checking the oil level

Every 3000 km (2000 miles) ensure the oil level is nearly up to inspection hole «A». If lower, top up with oil of same brand and density.

Oil change

Every 10.000 km (6000 miles) replace the oil in the rear drive box.

This replacement is best done on a warm engine when the oil is easier to be drained. Let the old oil drain fully before adding fresh oil.

«A» Level control cap.

«B» filler cap.

«C» Drain plug.

Quantity required: 0.250 lts. (abt. 8¹/₂ oz) of which 0.230 lts. (abt. 8 oz) Oil Agip F. 1. Rotra MP SAE 90 and lts. 0.020 (about 1/2 oz) Agip Rocol ASO/R. (Molykote type «A»).

4.5 FORK (LUBRICATION (fig. 8 and 9)

To replace the oil in the fork legs, proceed as follows:

- Undo drain plug with gasket «A».
- Undo bolt «B».

Before introducing fresh oil, let the fork legs drain fully.

«A» Fluid drain screw.

«B» Fluid filler cap.

Quantity required: 0.090 lts. (abt. 3 oz.) each leg. Oil: AGIP F. 1 ATF Dexron.

Lubrication of the steering and rear fork bearings

For this operation use «AGIP F.1 Grease 30».

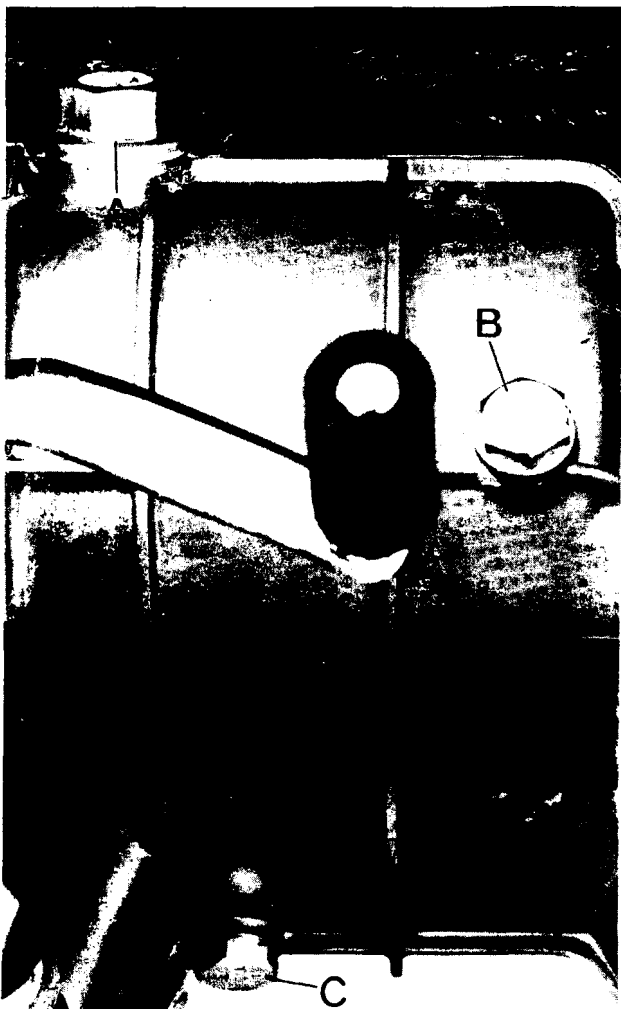

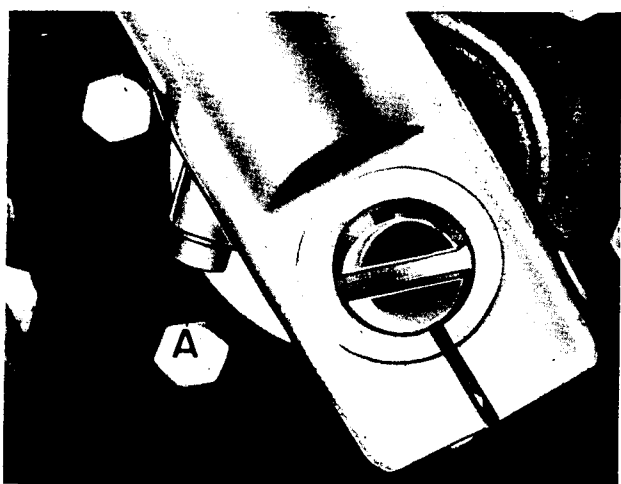
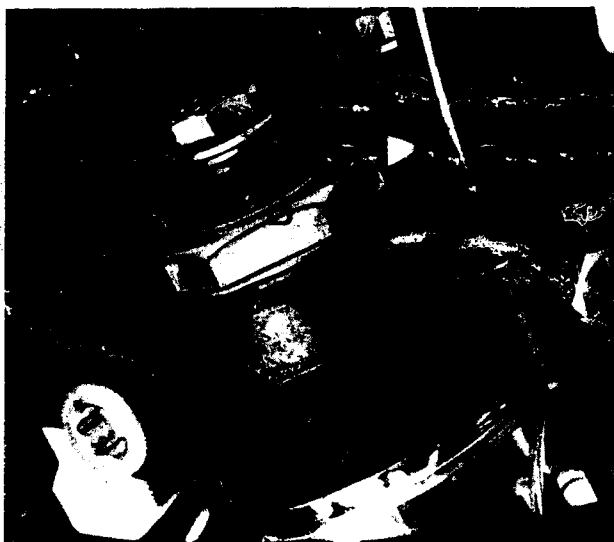
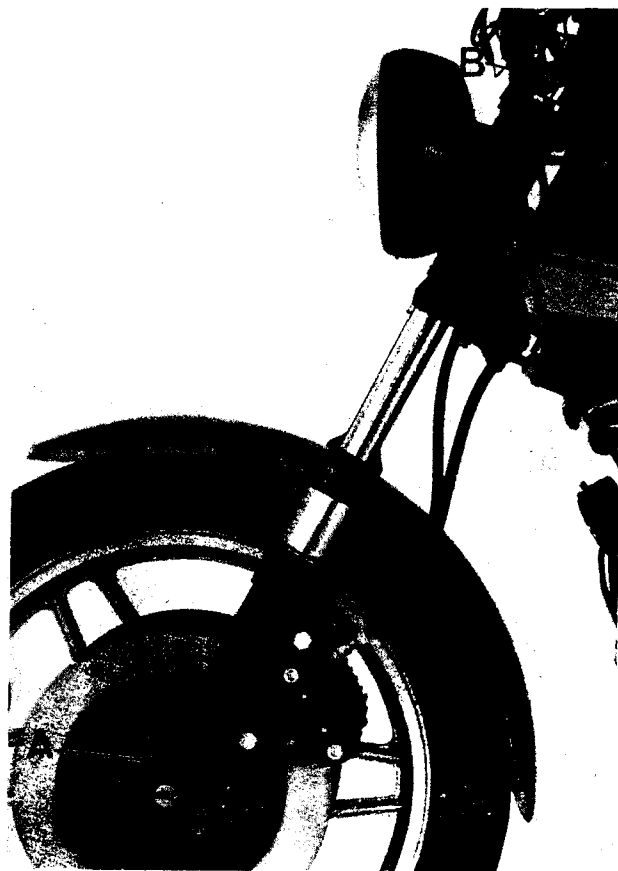
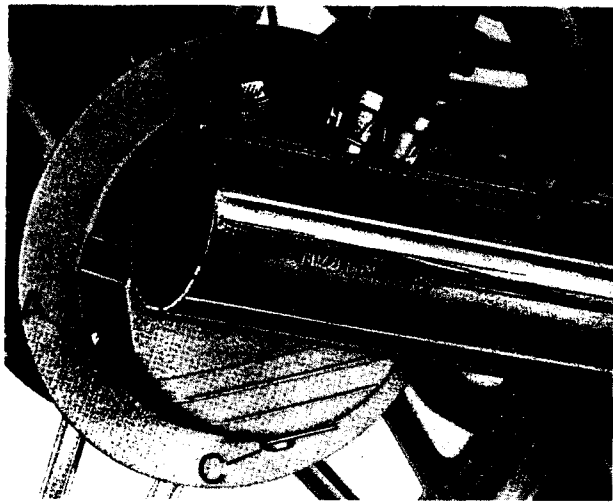

5 INSTRUMENTS AND CONTROLS

5.1 PANEL BOARD V 1000 G5 (fig. 10)

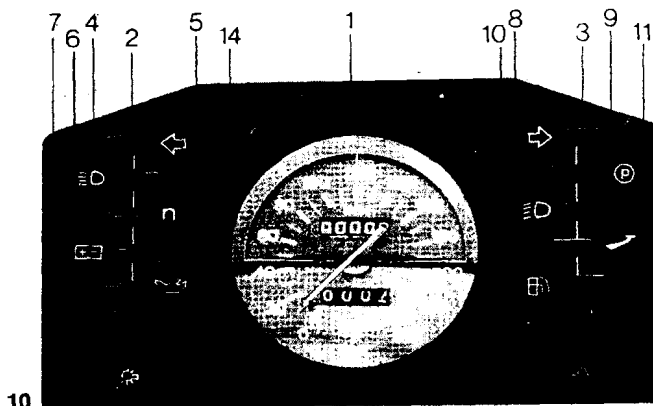

- 1 Speedometer in miles or km.
- 2 Warning light (green), left turn signal.
- 3 Warning light (green), right turn signal.
- 4 Warning light (blue), high beam on.
- 5 Warning light (orange), neutral indicator. It is lighted when the transmission is in neutral.
- 6 Warning light (red) indicating current delivery from generator. Should go out when the engine reaches a certain number of revolutions.
- 7 Warning light (red), oil pressure gauge. It goes out when the oil pressure is sufficient for normal engine lubrication. If it does not, this means that oil pressure is not correct and in such case the engine has to be stopped and the cause for the failure looked for.
- 8 Warning light (green) indicating side stand engaged. By turning the ignition key in position «A» (fig. 11) the light keeps on flashing. If the stand is not raised, the engine will not start.
- 9 Warning light (green) indicating parking lights «ON».
- 10 Warning light (red) indicating incorrect fluid level in the front left and rear brake reservoir. When this light is on, top up the fluid level and check if the braking circuit has any leakages.
- 11 Warning light (red), fuel reserve. To use the reserve fuel, bring the tap lever on the right fuel tank in position «RES» (fig. 19).
- 12 Courtesy light switch (available).
- 13 Switch, right and left rear emergency flashers.
- 14 Speedometer reset.

5.2 Ignition key V 1000 G5 (fig. 11)

The key has 3 positions:

«OFF» In line with panel mark - machine at standstill. Key removable.

«A» In line with panel mark (turned clockwise). Machine ready to be started. All circuits «ON». Key not removable.

«B» Turned clockwise in line with panel mark. Machine at standstill. With switch «A» fig. 11 in position «O», parking lights «ON». Key removable.

- 2 Rev-counter.

5.3 PANEL BOARD 1000 SP (fig. 12)

- 1 Clock.
- 2 Rev-counter.
- 3 Speedometer.
- 4 Voltmeter.

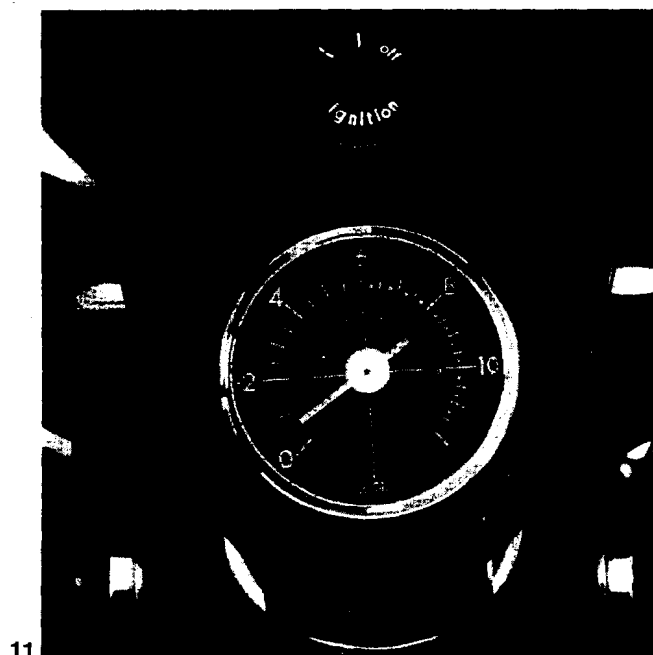

5 Ignition key:

«OFF» In line with panel mark «C». Machine at standstill. Key removable.

«A» In line with panel mark «C» (turned clockwise). All circuits «ON». Key not removable.

«B» In line with panel mark «C». Machine at standstill. With switch «A» in fig. 13 in position «O», parking light on. Key removable.

6 Warning light (green), left turn light.

7 Warning light (orange) indicating gearbox in neutral. Lights up when gearbox is in neutral.

8 Warning light (red) indicating current delivery from generator. Should go out as soon as the engine reaches a certain number of revolutions.

9 Warning light (red), oil pressure gauge. Goes out when oil pressure is sufficient for normal engine lubrication. If not, this means oil pressure is incorrect. In such case the engine should be immediately stopped and the cause for the fault looked for.

10 Warning light (red) indicating incorrect fluid level in the front and rear brake reservoir. When this light is on, top up the fluid level and check the braking circuit for leakages.

11 Warning light (blue), high-beam on.

12 Warning light (green), parking lights on.

13 Warning light (green), right turn signal.

14 Switch, right and left rear emergency flashers.

15 Speedometer zero reset.

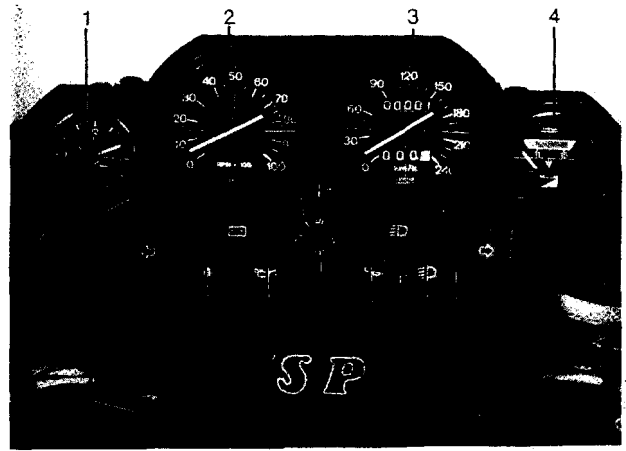

12

5.4 LIGHT SWITCHES (fig. 13)

Are located on the left handlebar.

Switch «A»

- Position «O» = parking lights.
- Position «1» = two-light lamp «ON».
- Position «2» = lights off.

Switch «B»

With switch «A» in position «1»:

- Position «4» = low beam.
- Position «5» = high beam.

5.5 HORN, TURN LIGHTS, AND FLASHING LIGHTS BUTTONS (fig. 13)

Are located on the left handlebar.

Button «C»

- 5 (horn button).
- 6 (flash) flashing light button.

Button «D»

- 7 left turn signals control.
- 8 right turn signals control.

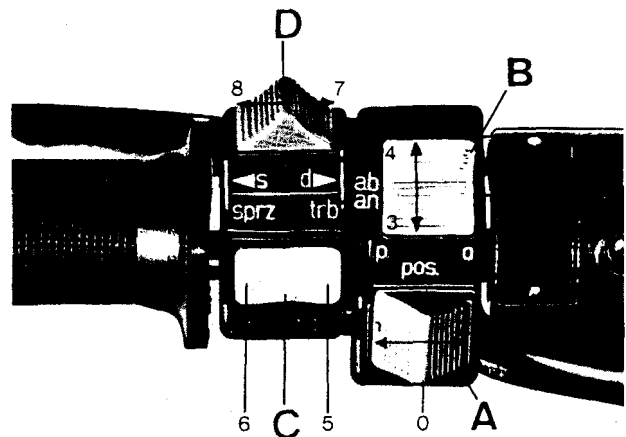

13

5.6 ENGINE STARTING AND EMERGENCY STOP BUTTON (fig. 14)

Right, on the handlebar. With ignition key in position «A», the engine is ready to be started.

To start the engine proceed as follows:

- Ensure switch «B» is in position «1».
- Pull clutch lever fully.
- On a cold engine, set easy starter lever on «A» (fig. 20)
- Push start button «A».

To stop the engine (in case of an emergency), move switch «B» in position «2».

After stopping the engine, turn the ignition key anti-clockwise until mark «OFF» is in line with the panel mark, and withdraw the key.

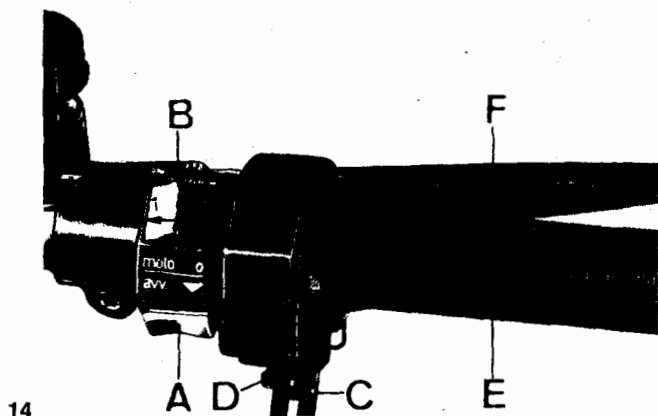

5.7 EASY STARTER LEVER (fig. 20 and 20/1)

The control lever for starting a cold engine is located on the L/H side of the vehicle.

«B» Starting position.

«C» Riding position.

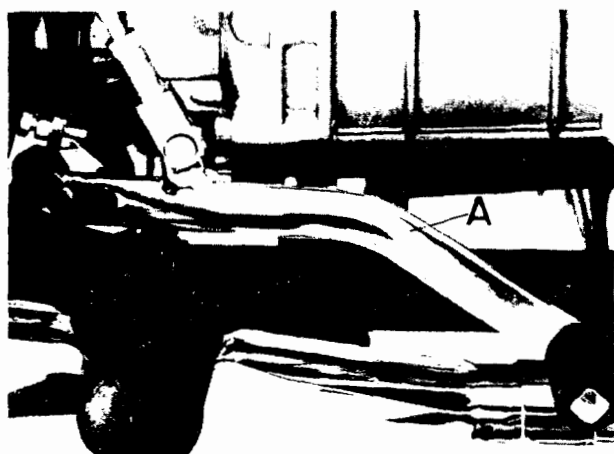

5.8 THROTTLE CONTROL GRIP («E» fig. 14)

Right, on the handlebar. Throttle is opened by turning towards the rider and viceversa.

5.9 CLUTCH CONTROL LEVER

It is on the left handlebar and should be used only for starting and gearshifting.

5.10 RIGHT FRONT BRAKE CONTROL LEVER («F» fig. 14)

Right, on the handlebar. It controls the front right master cylinder.

5.11 TWIN BRAKE CONTROL, FRANT LEFT AND REAR («A» fig. 15)

The control pedal is located on the R/H side of the motorcycle and is link connected to the master cylinder (fuel reservoir). It operates both front left and rear brakes at the same time.

5.12 GEARSHIFT PEDAL (fig. 16 and 16/1)

It is centrally located on the L/H side of the machine.

- 1st gear = pedal downwards.
- 2nd, 3rd, 4th, and top gear = pedal upwards.

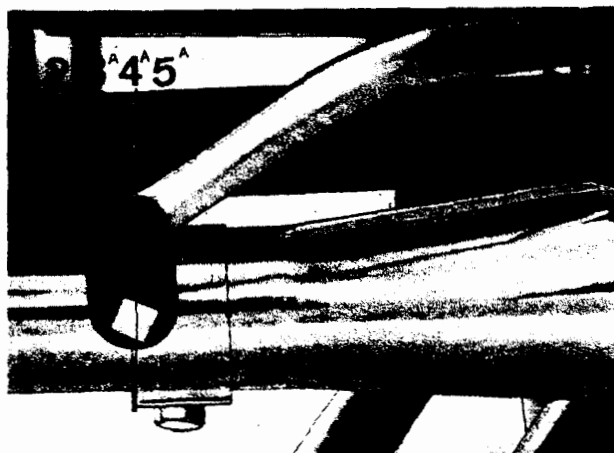
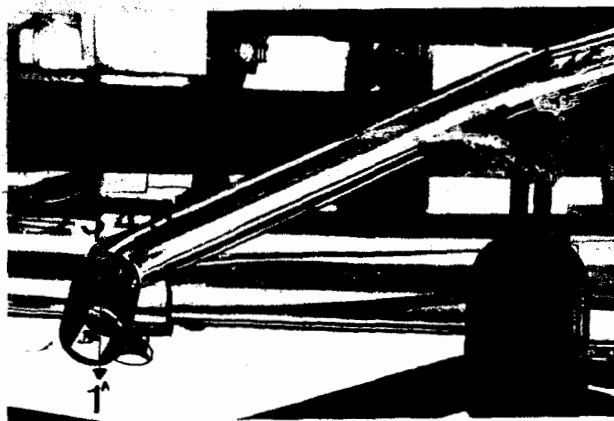

Before changing gear, it is necessary for the clutch lever to be pulled fully in.

5.13 FUEL FILLER CAP (fig. 17)

To lift up the filler cap cover, turn cover key «A» counterclockwise when the cap can be removed.

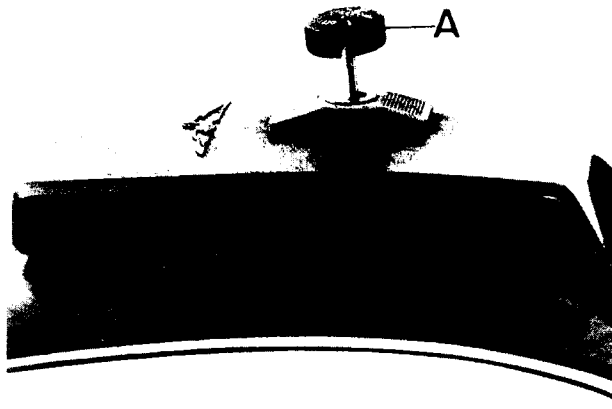

17

5.14 FUEL LEVEL V 1000 G5 («A» in fig. 18)

A panel indicator («11» in fig. 10) connected to a solenoid (A) on the right side of the tank indicates when the fuel level is in reserve.

5.15 FUEL TAP V 1000 G5 («B» in fig. 18)

It is located on the rear right side of the tank. It has 3 positions:

- «ON» = Open, arrow upwards.
- «RES» = Reserve, arrow downwards.
- «OFF» = Closed, arrow horizontal.



18

5.16 FUEL TAP 1000 SP (fig. 19)

It is located at the rear under the tank. It has 3 positions:

- «ON» = open, lever upwards.
- «RES» = reserve, lever arrow downwards.
- «OFF» = closed, lever horizontal.

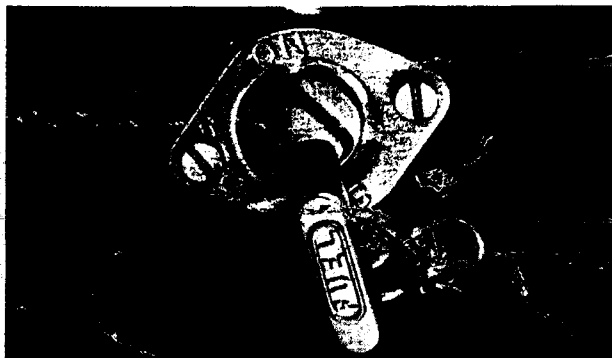

19

5.17 ELECTROVALVE V 1000 G5 («A» in fig. 20)

It fitted on the left hand side under the fuel tank and feeds the carburetors. Starts operating when ignition key (fig. 11) is in position «A».

5.18 TERMINAL BLOCK WITH FUSES (fig. 21)

It is located on the R/H side of the motorcycle. To accede to it, it is necessary to remove the right side cover and the block cover. The box fits 6 fuses of 16A.

Fuses V 1000 G 5 model

Key controiled

- «1» Tail light, horns, flashing lights.
- «2» Starter relay, warning light «n», electrovaive.
- «3» Warning lights (Oil - Gen - Brake - Fuel - Headlamp) - low and high beam and its warning light.
- «4» Parking lights - panel lights - warning light «L».

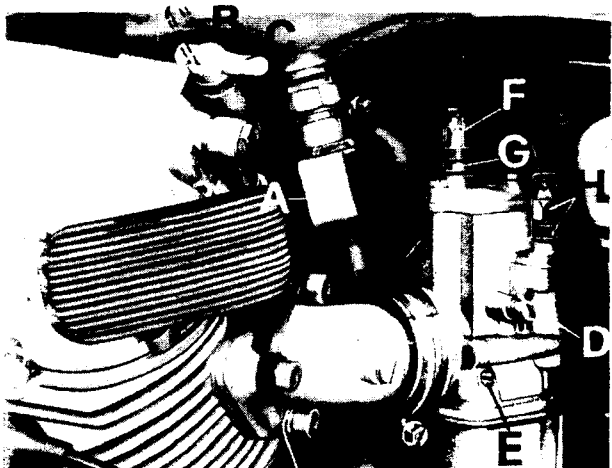

20

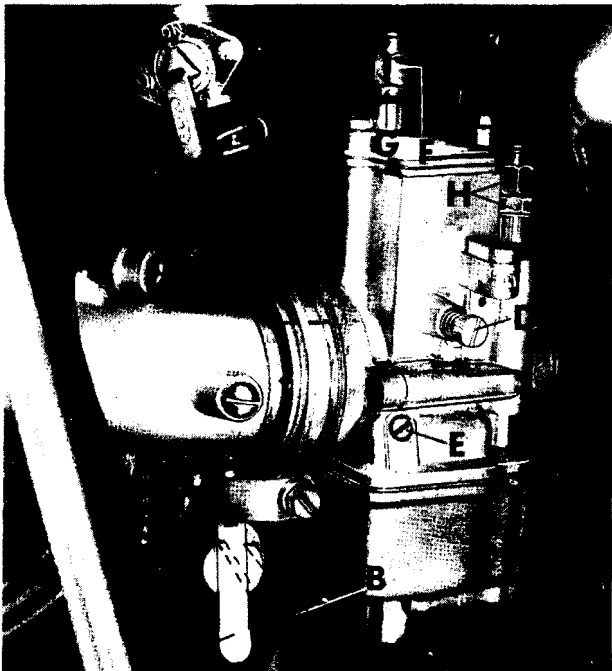

20/1

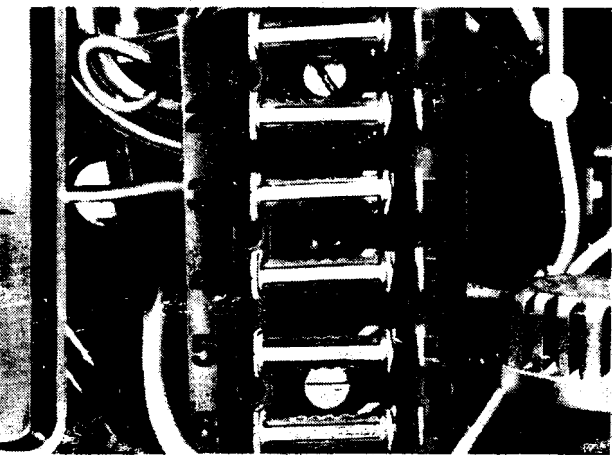

21



22

Out of key control

- «5» Additional courtesy light.
- «6» Turn signals and their indicator bulbs.

Fuses 1000 SP

- «1» Starter relay - stop cutout.
- «2» Flashing light solenoid - horns.
- «3» Warning lights: neutral, generator, oil pressure, brake fluid, parking, low and high beam, front stop cutout, parking lights, panel lights, high beam.
- «4» Parking lights, parking light indicator, panel lights.
- «5» Turn signal and their indicators.
- «6» Clock.

5.19 STEERING LOCK («A» in fig. 22)

To lock and unlock the steering proceed as follows

Locking

- Turn the handlebar fully to the right.
- Insert the key in the lock set, turn it counter-clockwise, and push it in fully. Then release it and take it out.

Unlocking

- Insert the key into the lock set, turn it counter-clockwise, release it and take it out.

5.20 SIDE STAND - V 1000 GS (see fig. 23)

The motorcycle is equipped with a side stand to be used for short stops only.

For longer stops, it is always advisable to set up the byke on the center stand. When the side stand is in the parking position (all out), a special device cuts off the current from the ignition coils.

When mark «A» on switch «1» is in line with the mark on the rev-counter panel, the warning light (see in fig. 10) on the panel warns that the side stand has to be raised before starting the engine or else it will not fire.

5.21 SIDE STAND - 1000 SP (fig. 24)

To be used only for short stops. Since the stand is automatically retractible, it is recommended to always set up the machine on the centre stand for greater stability.

5.22 STEERING DAMPER - 1000 SP (fig. 25)

It is fitted between the frame and steering yoke on the right hand side. To harden or loosen the steering: screw in or out nut «A».

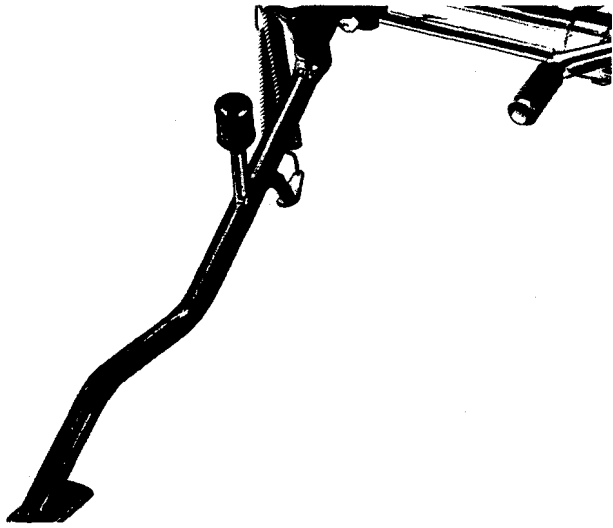

23

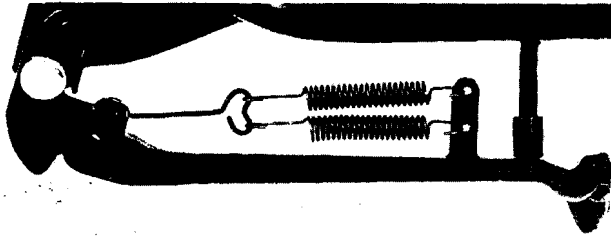

24

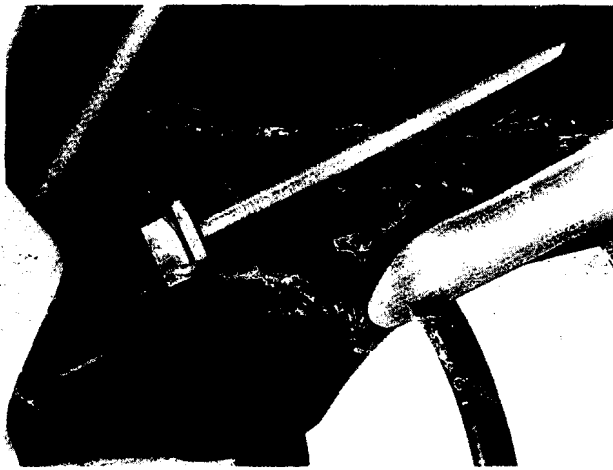

25

6 MAINTENANCE OPERATIONS AND ADJUSTMENTS

6.1 ADJUSTING THE CLUTCH LEVER PLAY (fig. 26)

If the handlebar play at the handlebar lever is more or less than 3-4 mm (abt. $\frac{1}{8}$ "), operate on the thumb screw to obtain the correct play. This adjustment can also be made by slackening locknuts «C» and operating on cable adjuster «B» on the right side of the gearbox.

26

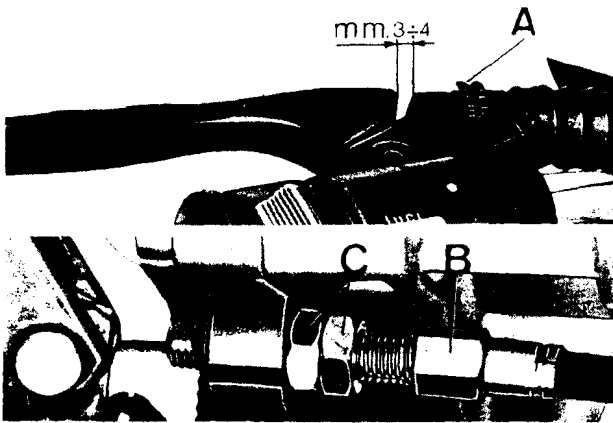

6.2 ADJUSTING THE RIGHT FRONT BRAKE LEVER (fig. 27)

Proceed as follows:

- Fit a feeler gauge «A» between floater in master cylinder and the control lever end. Then turn thumb screw «B» to obtain the correct play (0.05-0.15 mm = .0019-.0059").

27

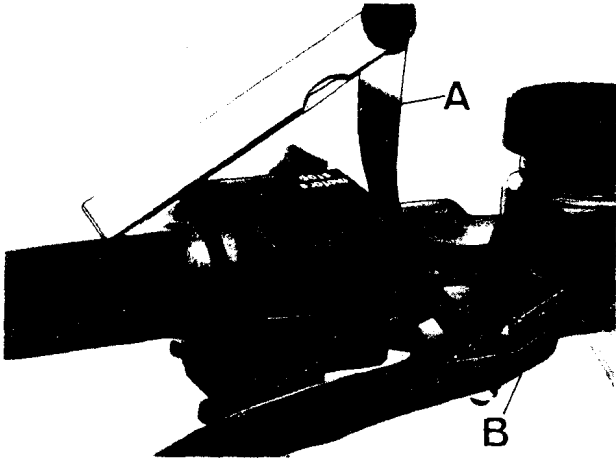

6.3 ADJUSTING THE FRONT LEFT AND REAR BRAKE PEDAL (fig. 28 and 28/1)

Check the floater-lever end play (G) as follows: Fit a feeler gauge between master cylinder floater and the operating lever end and act on eccentric screw «A». Correct play is 0.05-0.15 mm (.0019-.0059").

28

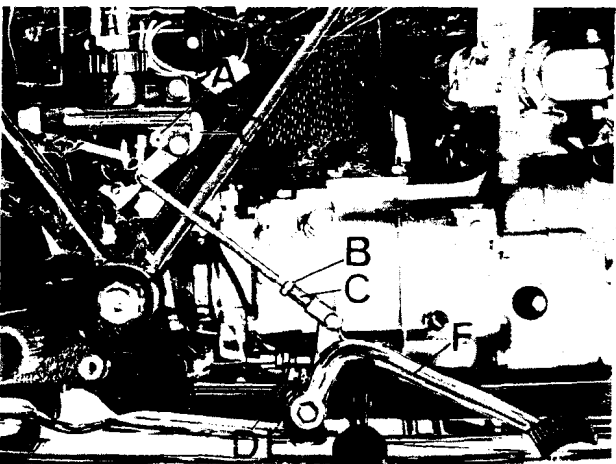

6.4 ADJUSTING THE REAR SUSPENSION (fig. 29)

The external springs of the rear suspensions can be adjusted to 3 positions by means of wrench «A». In case of faulty damper operation, have them checked by our dealers.

Do not forget that the two springs have to be adjusted to the same position to ensure good vehicle stability.

6.5 ADJUSTING THE STEERING (fig. 30 and 30/1)

For safe riding the steering has to be adjusted so that the handlebar can move freely without any play.

- Loosen steering head bolt «A».
- Undo steering head nut «B».
- Screw adjusting nut «C» in or out until the correct play is obtained.

After adjusting, re-tighten nut «B» and top steering head bolt «A».

6.6 ADJUSTING THE THROTTLE TWIST GRIP («D» and «C» in fig. 14)

To adjust the grip travel, screw in or out adjuster «D».

28/1

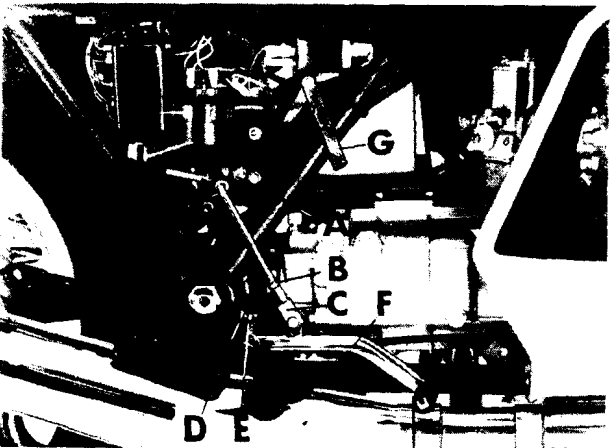

To adjust the grip return, screw in or out adjuster «C».

6.7 ADJUSTING THE WHEEL SPOKES - V 1000 G 5

Ensure that all spokes are properly tensioned and that the wheel rim is quite true. Proceed as follows:

■ Turn the wheel and using a locator, check if the wheel is offset. If necessary tighten or loosen the right or left spokes till the wheel turns without any wobbling. This check should be done after the first 500 km (300 miles) and then every 1500 km (900 miles).

6.8 ADJUSTING THE HEADLIGHT BEAM - V 1000 G5 (fig. 31)

For safe riding and in order not to disturb crossing riders, the headlight beam has always to be set at correct height.

Horizontal setting is adjusted by undoing screw «A» while vertical setting is adjusted through screw «C» and moving the headlight up or down until the correct height is obtained. The center of the high beam must not be higher than 0.870 meters (34") measured at 39,8 fb meters distance with motorcycle off the stand and the rider on the saddle.

6.9 ADJUSTING THE HEADLIGHT BEAM - 1000 SP (fig. 32)

For safe riding and in order not to trouble crossing riders, the headlight should always be set at correct height.

Horizontal setting is adjusted by screw «D», while vertical setting is adjusted by acting on the screw which secures the headlight to the fork covers until the correct height is obtained.

The center of the high beam must not be higher than 0.875 meters (34.4") measure at 3 meter (9.8 ft) distance with the machine off the stand and the rider on the saddle.

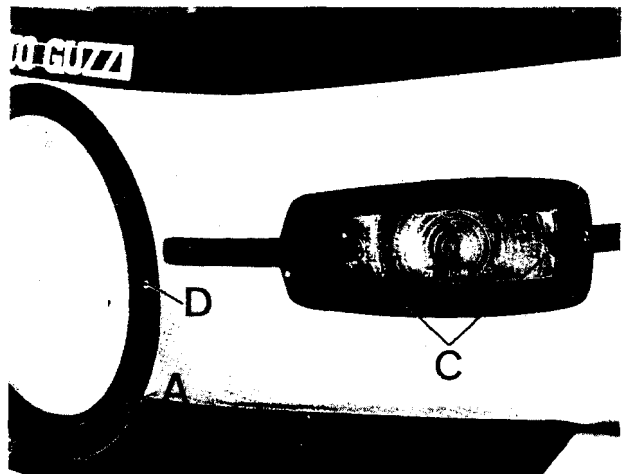
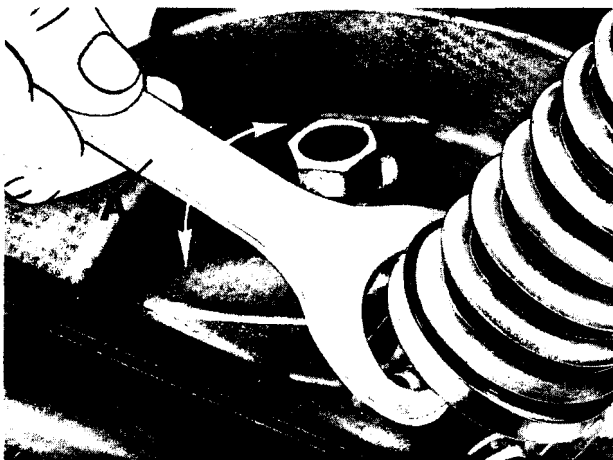
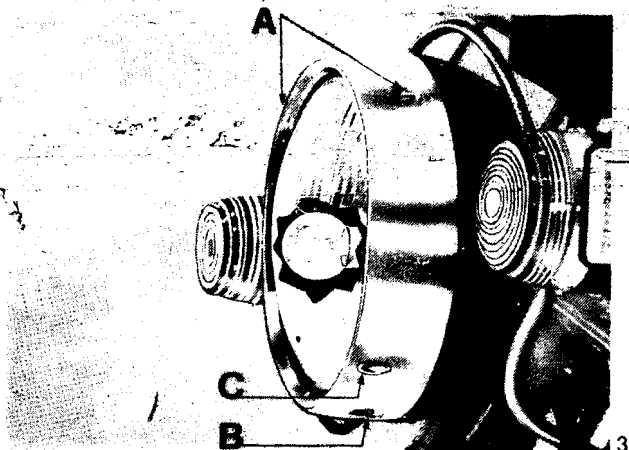
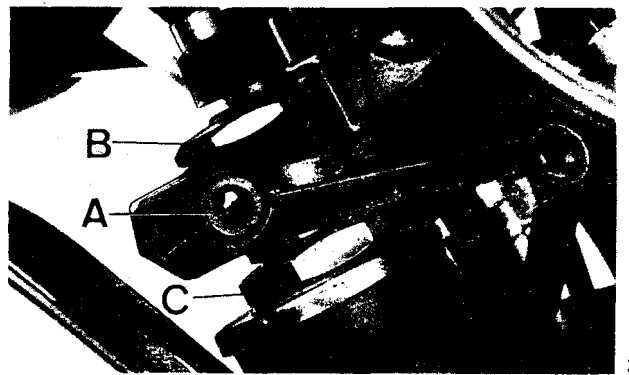
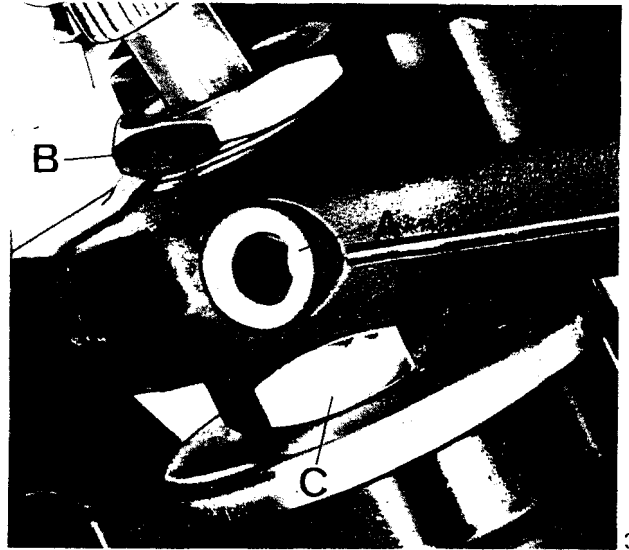

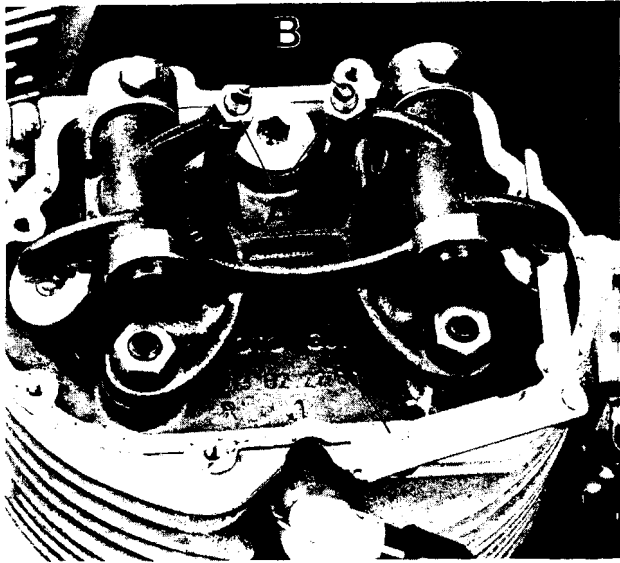

33

6.10 ROCKER CLEARANCE (fig. 33)

After the first 500-1000 km (3-600 miles) and later on every 3000 km (abt. 2000 miles) or any time valve operation is too noisy, check the rocker clearance. Do this adjustment on a **cold engine** with piston at TDC at the end of the compression stroke (valves fully closed).

After removing the rocker cover, operate as follows:

- Unscrew nut «A».
- Screw in or out adjuster screw «B» until the following clearance is obtained:
0.22 mm (.0085") for both the inlet and exhaust valve. Do this operation using feeler gauge «C».

If the clearance is too much, there will be noisy valve operation, if too little, the valves do not close fully causing inconveniences such as:

- Loss of compression.
- Overheating of engine.
- Burning of valves.

6.11 ADJUSTING THE DOUBLE CONTACT BREAKER (fig. 34)

Right cylinder (red cable)

Rotate the camshaft till the points are in their fully open position.

At this stage, introduce the blade of feeler gauge «A» between the points checking that the opening is correct i.e. 0.37-0.43 mm (.014-.016").

In case this distance is not as prescribed, slacken screws «C» and «D» and move the fixed point plate «E» acting on groove «F», to the right or left till the correct distance is obtained.

Left cylinder (green cable)

Proceed as for the right cylinder except that if it is necessary to adjust the points distance, screws «G» and «H» are to be loosened, moving the fixed contact plate «L» in groove «M» until the correct distance is obtained.

6.12 MAINTENANCE (fig. 34)

Every 3000 km (1800 miles), the cam felt plate should be lightly moistened with a few drops of oil.

Inspection

Proceed as follows:

- Remove the contact breaker cover after undoing its securing screws.
- If contacts «A» and «B» are dirty or greasy, clean them with a petrol moistened rag. If in any way damaged, replace them.
- Check points gap of breaker «A» (right cylinder - red cable) and breaker «B» (left cylinder - green cable) which should be 0.37-0.43 mm (.014-.016").

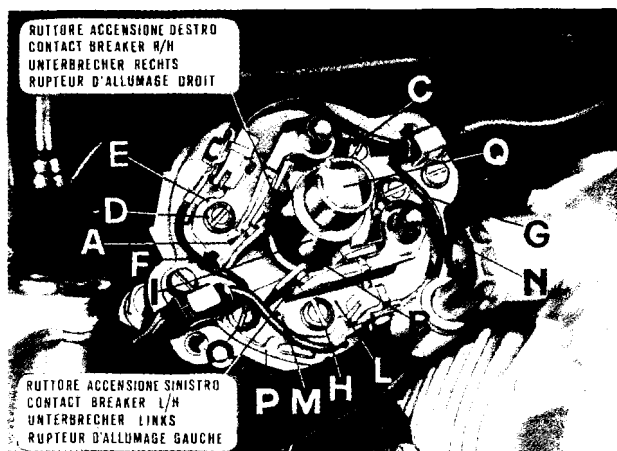

34

6.13 CLEANING THE WINDSHIELD

Any type soap, cleansing agent, polish or polishing wax normally used to clean plastic or glass materials can be utilized.

However, the following precautions should be taken:

- Never wash or clean the windshield when the external temperature is very high or after exposure to the sun.
- Under no circumstances, solvents, lyes, or similar products should be used.
- Do not use liquids containing abrasive materials, pumice powder, emery paper, scrapers or suchlike.
- Before polishing ensure that all dust and impurities are removed.
- Light scratches can be smoothed out with light polish.
- Fresh paint or sealing compounds, when still wet, can easily be removed by lightly rubbing off with isopropyl alcohol, soluble mineral oil, butyl or cello-solve (Never use methyl alcohol).
- Use a soft sponge or cloth, chamois leather or cottonwool, rubbing lightly.
- Never use paper towels, synthetic fiber clothes which may scratch the windshield surface.

Vigorous rubbing or solvents will not remove deep scratches or nicks.

7 LUBRICATION AND MAINTENANCE CHART

Monthly (or every 3000 km - abt. 2000 miles)

Check the electrolyte level in the battery.

Periodically

Check tire pressure

Every 500 km (300 miles)

Check the oil level in the crankcase.

After the first 500-1000 km (300-600 miles)

Replace the oil in the crankcase.

Replace the oil cartridge.

Check tightness of all nuts and bolts.

Check rocker clearance.

Check tightness of all wheel spokes and trueness of the rims. (Only for V1000 G5)

Every 1500 kms (abt. 900 miles)

Check that all wheel spokes are tight and the wheels true (only for model 1000 G5)

Every 3000 km (2000 miles)

Replace the oil in the sump.

Check level of oil in the gear box.

Check level of oil in the rear drive box.

Check rocker clearance.

Every 5000-6000 km (3000-4000 miles)

Check fluid level in the reservoir (master cylinder) for the right front brake. An incorrect fluid level in the reservoir for the left front brake and rear brake is indicated by a warning light (red) on the instrument panel.

Every 10000 km (6000 miles)

Clean the fuel tank, filters, and fuel pipes.

Replace the oil in the gearbox.

Replace the oil in the rear drive box.

Clean and grease all battery connections

Replace the air filter.

Every 15000 km (9000 miles)

Replace the fluid in the braking circuits.

Replace the oil filter cartridge and clean the wire gauze filter.

Every 20000 km (12000 miles)

Check condition of the wheel bearings.

Check if the steering bearings are sufficiently greased and in good condition.

Replace the oil in the fork legs.

Clean starter motor and generator commutators using a clean rag lightly moistened with petrol.

8 TORQUE WRENCH SETTINGS

DESCRIPTION	SETTING
Bolts and studs, cylinder head-cylinder to crankcase	4-4.2 kgm (29-30 ft/lbs)
Spark plugs	2-3 kgm (14-21 ft/lbs)
Cap screw, oil mist recovery pipe (dia. 12 x 1,5 mm ".47 x .059")	4 kgm (29 ft/lbs)
Self locking nut, con-rod caps securing bolts	4.6-4.8 kgm (33-34 ft/lbs)
Bolt, rocker pin securing	0.6-0.8 kgm (4.2-4.5 ft/lbs)
Bolt, flywheel to crankshaft	4.2 kgm (30 ft/lbs)
Nut, gear to camshaft	15 kgm (108 ft/lbs)
Screws, intake pipe	2 kgm (14 ft/lbs)
Cap screw, oil delivery pipe to cylinder head (8 x 1,25" .31 x .059")	1.5-1.8 kgm (10.5-12 ft/lbs)
Nut, front and rear engine securing studs to frame	8 kgm (57 ft/lbs)
Nut, layshaft securing	16-18 kgm (115-130 ft/lbs)
Oil filler plug, on gearbox and rear drive box	3 kgm (21 ft/lbs)
Oil level and drain plugs, gearbox and rear drive box	2.5 kgm (18 ft/lbs)
Safety nut, layshaft	7-8 kgm (50-57 ft/lbs)
Nut, bearing to bevel pinion	18-20 kgm (130-145 ft/lbs)
Screw, crown wheel to hollow spindle	4-4.2 kgm (29-30 ft/lbs)
Bolts, cradle to frame securing	8 kgm (57 ft/lbs)
Nut, cradle to frame securing screws	8 kgm (57 ft/lbs)
Cap nuts, swing arm spindle	8 kgm (57 ft/lbs)
Nuts, drive box to swing arm	3.5 kgm (25 ft/lbs)
Top plugs, front fork	12-15 kgm (87-108 ft/lbs)
Nut, front and rear wheel spindle	14-15 kgm (100-108 ft/lbs)
Bush, steering lock	17-18 kgm (122-130 ft/lbs)
Standard settings	
Screws and nuts, dia. 6 mm (.23")	0.8-1.2 kgm (4.5-8 ft/lbs)
Screws and nuts, dia. 8 mm (.31")	2.5-3 kgm (18-21 ft/lbs)
Screws and nuts, dia. 10 mm (.39")	4.5-5 kgm (33-37 ft/lbs)

9 SPECIAL TOOLS FOR REPAIR SHOPS

(fig. 35)

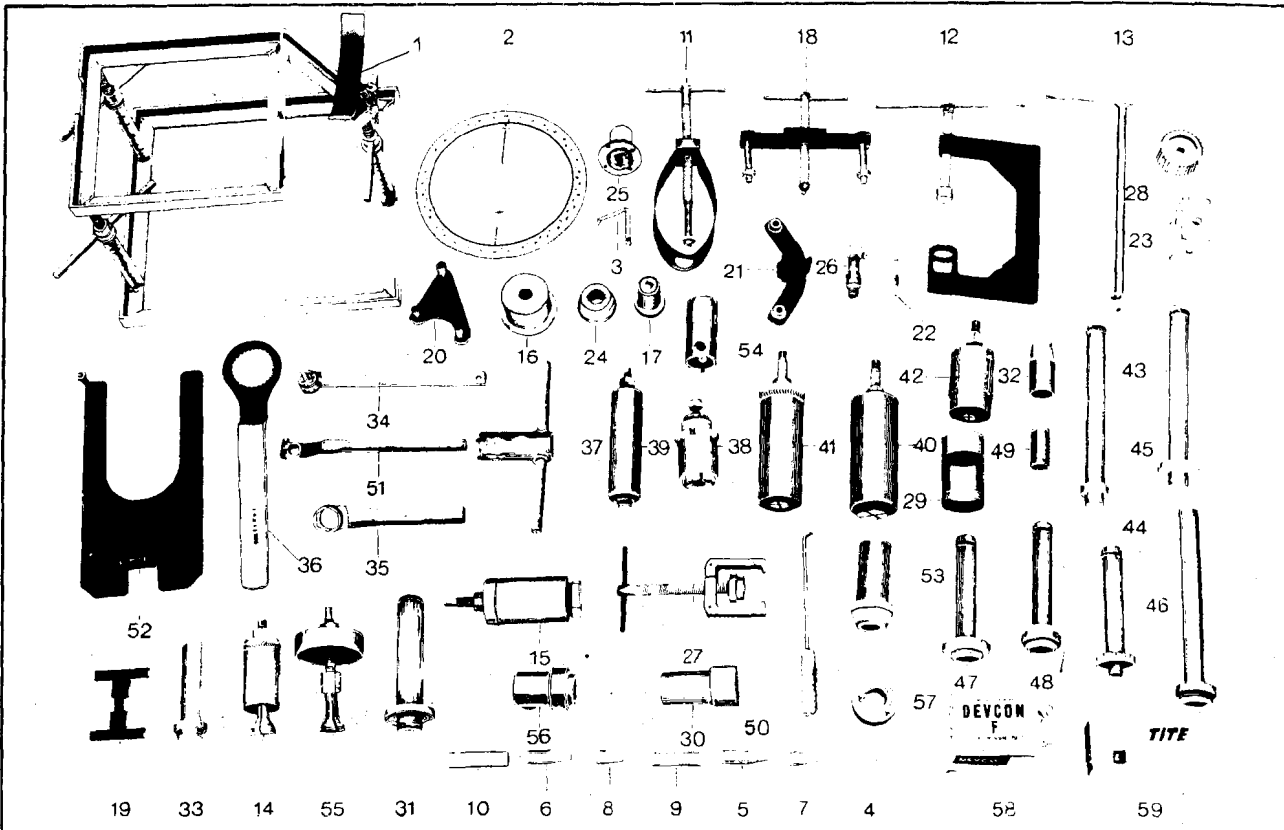

35

N°	PART N°	DESCRIPTION
1	18 91 24 50	Engine support.
2	19 92 74 00	Timing plate.
3	17 94 75 60	Arrow, index for timing check.
4	14 92 64 00	Tool, floater removal from master cylinder.
5	18 92 65 00	Tool, lip seal mounting on R/H front brake master cylinder floater.
6	14 92 65 00	Tool, lip seal mounting on L/H front and rear brake master cylinder floater.
7	18 92 66 00	Tool, toroidal seal assembly on floater of master cylinder for right front brake.
8	14 92 66 00	Tool, toroidal seal assembly on floater of rear and left front brake master cylinder.
9	18 92 67 00	Tool, clamp ring assembling, on R/H brake master cylinder.
10	14 92 67 00	Tool, clamp ring assembling on front L/H and rear master cylinder.
11	26 90 78 00	Puller, piston pin.
12	10 90 72 00	Tool, valve dismantling and assembling.
13	14 92 70 00	Spanner, adjusting nut and twin contact breaker dismantling.
14	12 90 47 00	Puller, taper bearing races, swing arm.
15	12 90 69 00	Puller, taper bearing races, rear drive box.
16	14 92 71 00	Tool, seal mounting on flange, drive side.
17	14 92 72 00	Tool, retainer assembling on timing cover.
18	12 91 36 00	Tool, flange removal, drive side.
19	14 92 69 00	Template, control of parallelism and carburetor floater level.
20	14 92 73 00	Tool, holdfast, camshaft gear.
21	12 91 18 01	Tool, holdfast, flywheel and starter ring gear.
22	14 90 66 00	Pin, generator rotor removal.

N°	PART N°	DESCRIPTION
23	17 94 97 60	Tool, oil pressure relief valve and solenoid control.
24	12 91 20 00	Tool, flange assembly, drive side, c/w seal on crankshaft.
25	17 94 96 60	Hub, timing plate.
26	17 94 82 60	Stand, comparator.
27	17 94 83 60	Puller, inner race of roller bearing on hollow spindle in drive box.
28	12 90 65 00	Tool, clutch assembly.
29	12 90 59 00	Tool, clutch shaft stripping.
30	17 94 84 60	Tool, pressing roller bearing inner race on hollow spindle in rear drive box.
31	17 94 53 60	Punch, pressing in bearing on right arm of swing fork.
32	17 94 54 60	Tool, pressing in bearings inner race on main shaft and clutch shaft.
33	17 94 52 60	Punch, pressing bearing outer races on swing arm.
34	12 90 71 00	Tool, holdfast, layshaft.
35	14 90 54 00	Tool, layshaft securing nut.
36	14 91 28 00	Tool, clutch inner body fixing.
37	14 91 26 00	Hook wrench, lockring for clutch inner body to shaft.
38	14 92 85 00	Tool, removal of clutch shaft bearing inner race.
39	14 91 31 00	Puller, roller bearing for mainshaft in box and clutch shaft on cover.
40	17 94 50 60	Puller, outer race of roller bearing.
41	17 94 92 60	Puller, clutch shaft bearing in box and layshaft on cover.
42	14 90 70 00	Puller, main shaft ball bearing on cover.
43	14 92 89 00	Punch, pressing clutch shaft bearing in box and layshaft bearing in cover.
44	14 92 91 00	Punch, for pressing in outer race of layshaft roller bearing in box.
45	14 92 88 00	Punch, for pressing in mainshaft roller bearing in box and clutch shaft bearing in cover.
46	14 92 90 00	Punch, for pressing in main shaft ball bearing in cover.
47	14 92 94 00	Punch, for pressing in clutch shaft seal in gear box.
48	14 92 95 00	Punch, for pressing in mainshaft seal in cover.
49	14 92 86 00	Tool, for pressing in inner bearing race on layshaft.
50	14 92 93 00	Tool, for locating striker forks on sliding muffs.
51	14 92 87 00	Tool, preselector actuation.
52	14 92 96 00	Support, gearbox.
53	17 94 51 60	Punch, pressing in outer races of bearing in housing.
54	18 92 76 50	Wrench, camshaft gear securing nut and engine sprocket ring nut.
55	18 92 72 50	Puller, cardan joint bearings on right arm of swing fork.
56	17 94 88 60	Punch, outer bearing race and seal in rear drive box.
—	19 92 71 00	Tool, seal mounting on flange drive side.
SPECIAL PRODUCTS		
57	00 01 00 00	Telfon, retaining tape for threadings.
58	00 01 02 00	Devcon «F», compound for blowholes in crankcase, gearbox, rear drive box, and covers.
59	00 01 04 00	Loctite «601» for bearing, nuts, and bolts.

10 REMOVING THE ENGINE-GEARBOX UNIT FROM FRAME

10.1

When dismantling be sure to keep all the various component groups well apart from each other (cylinder barrel, con-rods-piston of R/H side from those of L/H side). This will make the re-assembly operations much easier and avoid possible misplacements.

10.2 REMOVAL

Proceed as follows:

- 1 Lift up the saddle and remove tool box.
- 2 Disconnect positive and negative cables from the battery, remove retaining straps, and withdraw the battery from its housing.
- 3 Close fuel taps, slip off pipings from taps, unhook retaining straps, and remove the fuel tank.
- 4 Undo the screws and remove generator cover, disconnecting all leads.
- 5 Undo the nuts and remove the exhaust pipe retaining clips to the cylinder head.
- 6 Slacken the front combustion chamber retaining clips to the exhaust pipes, undo the muffler retaining screws to the frame, and take away the complete exhaust assembly (pipes, combustion chamber, and mufflers).
- 7 For model 1000 SP, remove both cowls after undoing their securing screws.
- 8 Set up support part n. 18 91 24 50 (1 in fig. 35) and lightly tension the sides.
- 9 Disconnect all the engine-gearbox-frame connections:
 - Unhook the speedo cable from the drive on the gearbox cover.
 - Unscrew the rev-counter cable from its drive on the timing cover.
 - Undo the screw securing the intake pipes to the cylinder heads (for model V1000 G5, undo also the screw securing the rocker cover, and take out the starter control device).
 - Slip off the spark plugs caps.
 - Undo nut and pin, removing the gearshift, pedal stays and the brake pedal.
 - Undo the 4 bolts retaining the battery bracket to the gearbox.
 - Remove the rear wheel (see para. 23.3).
 - Undo the nuts and lift out the rear suspensions from the swing arm.
 - Undo the nuts and the swing arm securing pins to the frame.
 - Lift out the swing arm complete with cardan joint and rear drive box.
 - Undo the nuts and remove the studs securing the complete engine-gearbox assembly to the cradle.
 - Lift up the rear end and take off the frame complete with front fork and wheel.
 - After removing the frame assembly, remove the cradle arms from the engine-gearbox unit by undoing their retaining screws.
 - Wash down the engine-gearbox assembly using a brittle brush and kerosene. Dry off with compressed air.
 - Separate the engine from the gearbox.

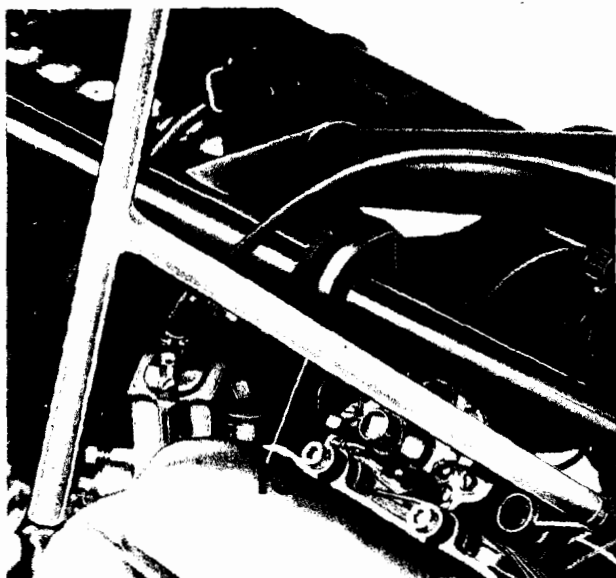

11 STRIPPING THE ENGINE

Operate as follows:

- Drain the oil sump.
- Undo the screws securing the twin breaker assy to the crankcase. Using special wrench N. 14 92 70 00 (13 in fig. 36). Take out contact breaker assy. together with retainer plate.
- To dismantle the clutch assembly from the flywheel proceed as follows:
 - Fit the clutch hub tool part N. 12 91 18 01 (21 in fig. 37) to prevent the hub from turning.
 - Fit tool N. 12 90 65 00 (28 in fig. 37) for centering the plates on the crankshaft.
 - Using wrench «A», undo the hub securing screws to the flywheel.
 - Undo the 3 stator retaining screws.
 - Undo the screw securing the stator to the crankshaft.
 - Introduce pin 14 90 66 00 (22 in fig. 38) in the shaft drilling.
 - Screw in the bolt till the rotor comes away and remove this together with the stator.
 - Undo the retaining screws and remove timing cover.
 - Undo the screws and remove rocker covers.
 - Bring the piston of one cylinder to TDC (valve closed), after removing the spark plug, undo both

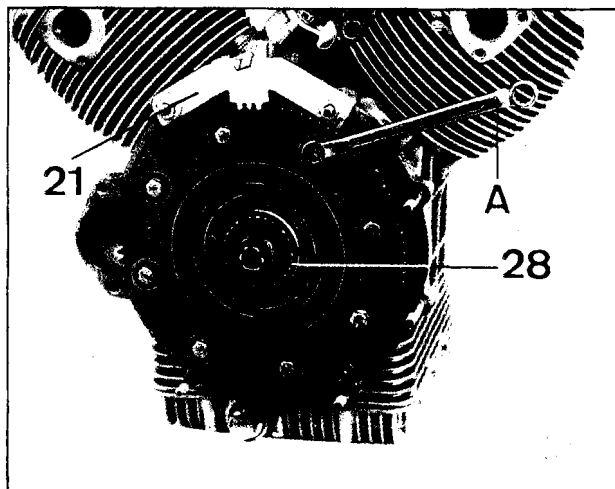

37

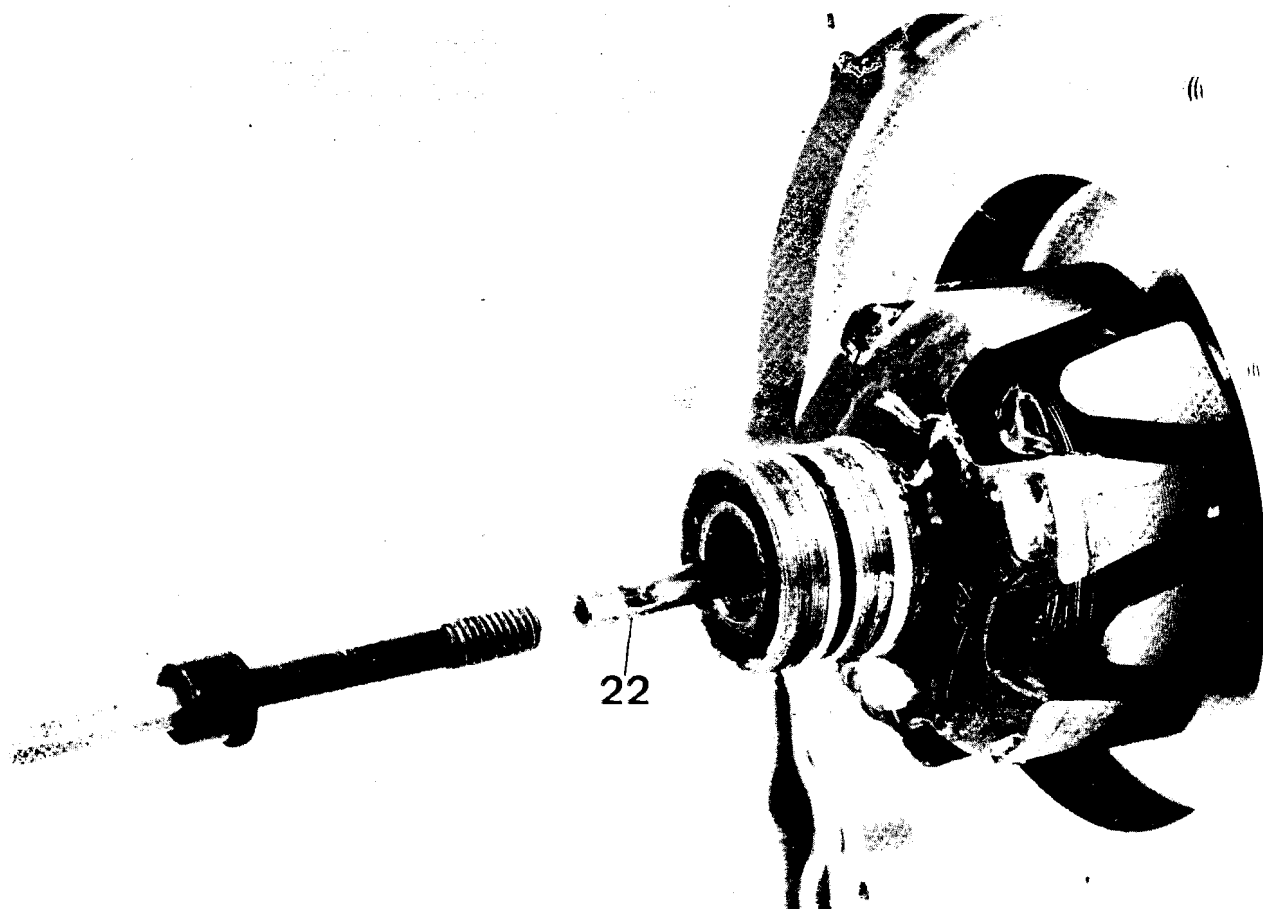

38

37

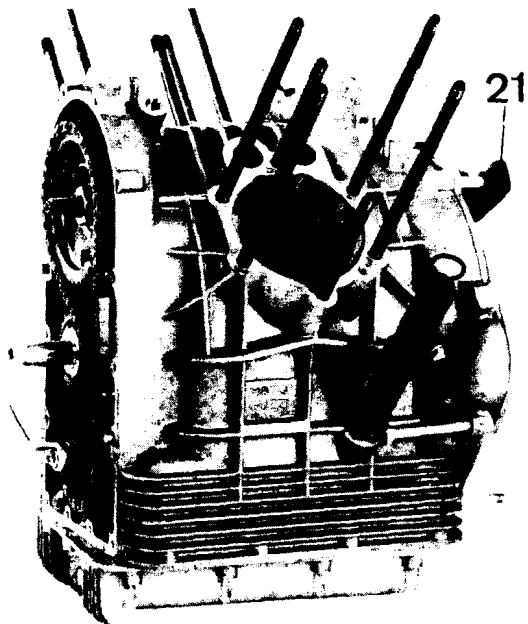

rocker pin securing screws and take these out with their washer and spring. Remove push rods. Proceed likewise for the other cylinder.

- Fit flywheel holding tool part N. 12 91 18 01 (21 in fig. 41) on the crankcase studs.

- Undo the oil pump gear retaining nut (see fig. 39).

- Undo the engine sprocket locking ring (after flattening the lockplate flaps) using wrench 18 92 76 50 (54 in fig. 39/1).

- Undo timing gear retaining nut using wrench 18 92 76 50 (54 in fig. 40).

- From the crankshaft, timing and oil pump shaft, the complete timing assembly complete with gears and chain.

- Remove the chain tensioner by undoing its 2 retaining screws.

- After undoing the 4 retaining nuts, cap and both studs remove: rocker supports, cylinder head, gaskets, and cylinder barrels.

- Using holdfast tool N. 12 91 18 01 (21 in fig. 41) fitted on the crankcase studs, undo the flywheel retaining bolts to the crankshaft. Remove the tool and the flywheel.

- Using pin-pointed pliers N. 26 90 78 00 (11 in fig. 42), extract the piston pins and remove the pistons.

- Remove oil sump «C» from the crankcase, remove oil filtering cartridge «A», wire gauze filter «D», after straightening the tab washer. Screw out oil relief valve «E» (fig. 5).

- Undo the connecting rod cap nuts and take the caps (from the bottom), the con-rods (from the top).

- Remove the tappets from their housings in the crankcase.

- Undo retaining screws, remove flange, and withdraw the camshaft.

- Undo the screws and using tool part N. 12 91 36 00 (18 in fig. 43), remove the drive side flange from the crankcase.

- Draw out the crankshaft from the drive side.

- Undo the screws and from the crankcase remove the timing side flange.

- Remove the oil pressure solenoid.

- Loosen the clip screws, and remove both rubber tubes.

- Remove the oil breather valve from the tube and remove the tube with washer from the crankcase.

- Undo the hollow screw, the clip retaining screw, and withdraw the tubing.

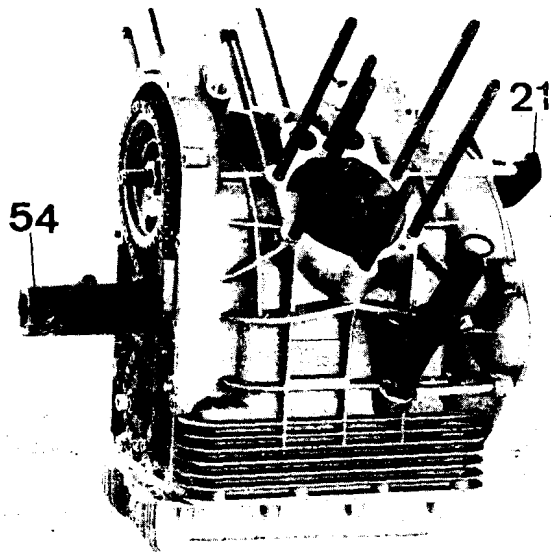

39/1

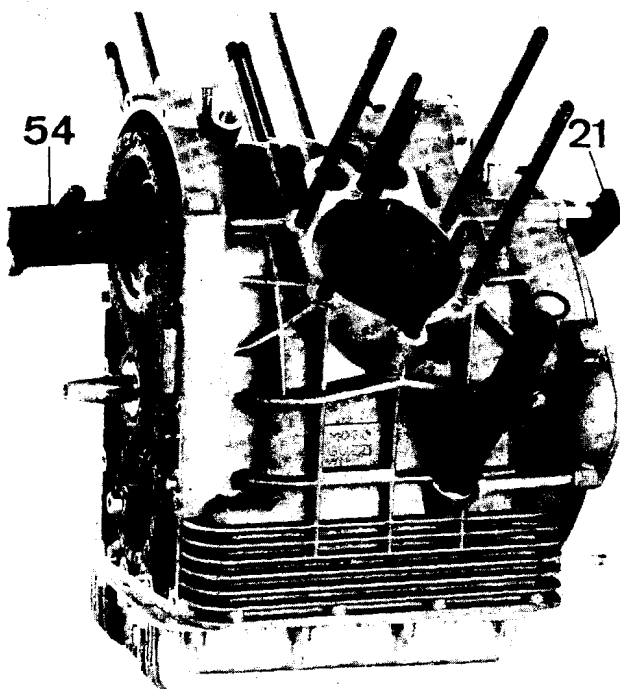

40

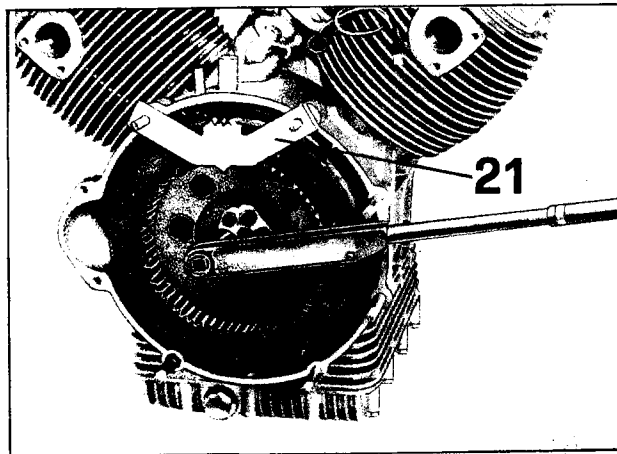

41

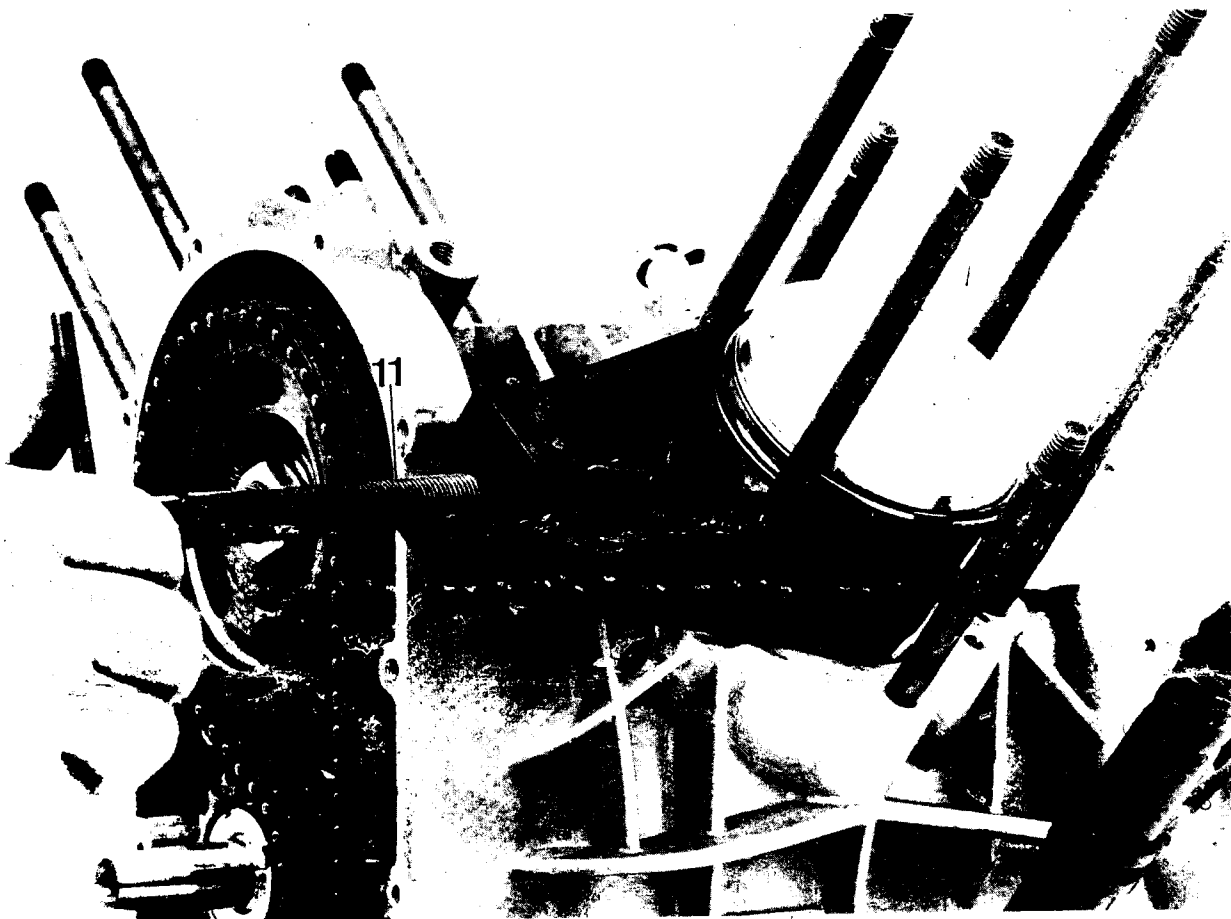

42

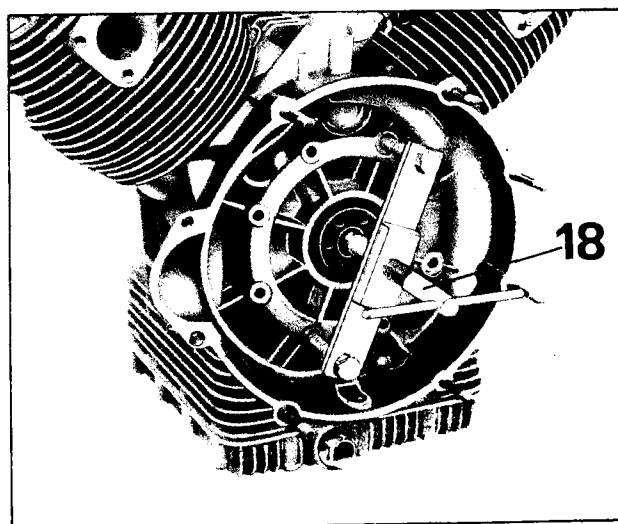

43

12 OVERHAULING AND CHECKING OPERATIONS

12.1 ROCKER COVERS

Ensure the union faces are not scored or nicked in such a way as to impair tightness. Replace cover as necessary.

12.2 STRIPPING OF CYLINDER HEADS

- Fit tool 10 90 72 00 (12 in fig. 46) on the top collar and in the center of the valve head.
 - Screw in the spring compressor tool screw till the spring is compressed (do this moderately so as not to deform the tool). Lightly tap the tool on top to break away the collets from the top collar.
 - Now screw in the tool until the collets can be drawn out.
- Remove the tool.

At this stage, the following can be drawn out: top collar, inner spring, outer spring, bottom collar, shims (if any), and the valve itself from the inside.

12.3 CYLINDER HEADS

Inspect that:

- No cooling fins are broken.
- The rocker covers faces are not nicked or scored so as to impair tightness.

This done, proceed as follows:

- Remove all carbon deposits using a blunt scraper and a metal brush.



44

Inspect that:

- No cooling fins are broken.
- The rocker covers faces are not nicked or scored so as to impair tightness.

This done, proceed as follows:

- Remove all carbon deposits using a blunt scraper and a metal brush.

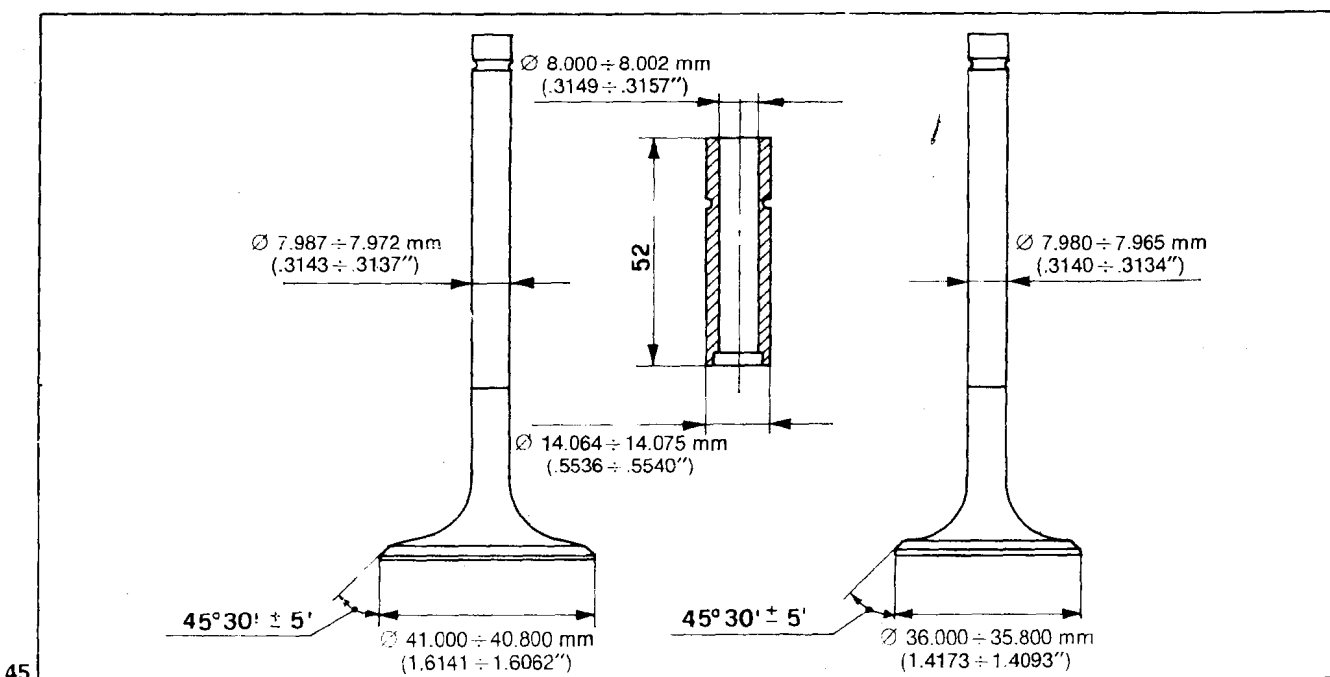

45

- Check if the valve stem-guide tolerance is still within the specified limits (see table «Valve-guide coupling data»).
 - Check if the seats are burnt out or damaged in such a way as to prevent tightness.
- For valve guide replacement and grinding in of valve seats, see para. 12.4 and 12.5.

12.4 VALVE GUIDES

The valve guides are best removed from the head by the aid of a punch. The guides have to be replaced when the valve stem-guide clearance cannot be taken up by the simple replacement of the valves. Valve guides are pressed in as follows:

- Pre-heat the cylinder head in an oven at about 60° C (140° F), lubricate the guides, and press them home as far as possible by the aid of a drift.
- Fit the snap rings.
- After pressing in the guides, ream out the bores where the valve stem slides to the size indicated in table «valve-guide clearances», fig. 44 and drawing fig. 45.

Negative allowance between cylinder head and valve guide should be comprised 0.046-0.075 (.0017-.0029«).

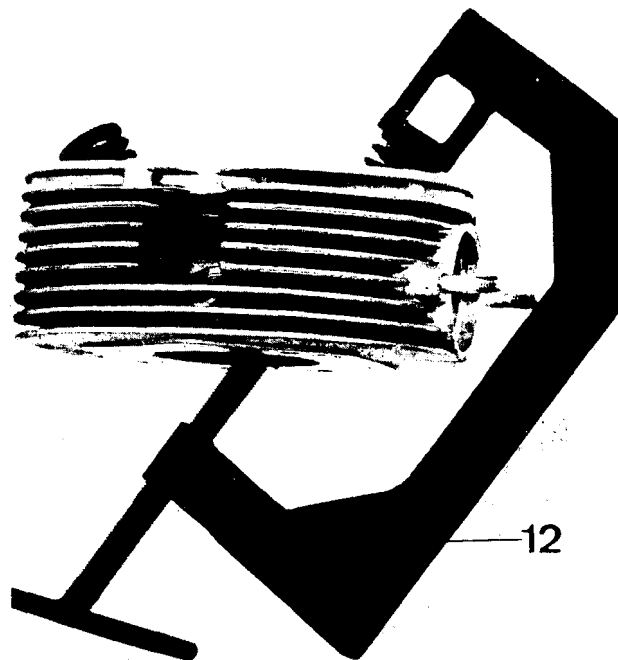

46

Valve-guide clearances

	VALVE GUIDE I/D	VALVE STEM D/A.	CLEARANCE ON ASSEMBLY
Inlet	8.000-8.022 mm (.3144-.3158")	7.972-7.987 mm (.3199-.3143")	0.013-0.050 mm (.00051-.0019")
		7.965-7.980 mm (.3134-.3140")	0.020-0.057 mm (.00079-.0022")

12.5 VALVE SEATS

Change the valve seats if pitted.

Seat angle is 45°30'±5' for both inlet and exhaust valve.

After re-facing, for a satisfactory gas seal, it is necessary to grind in the seat making sure that no grinding paste whatever remains on the valve stems as this will cause in a short time a lapping process whilst the engine is running.

At the end of the grinding operation, it is well to check if the seat is perfectly gas tight. This is best done by mounting the valves in the cylinder head and pouring some petrol into the intake and exhaust ducts, watching if any seeps through the valve seat.

12.6 VALVES

Check if the valve stems are scored or damaged, also the guide-stem clearance is within the prescribed limit.

Ensure the valve-head angle is 45°30'±5'.

41

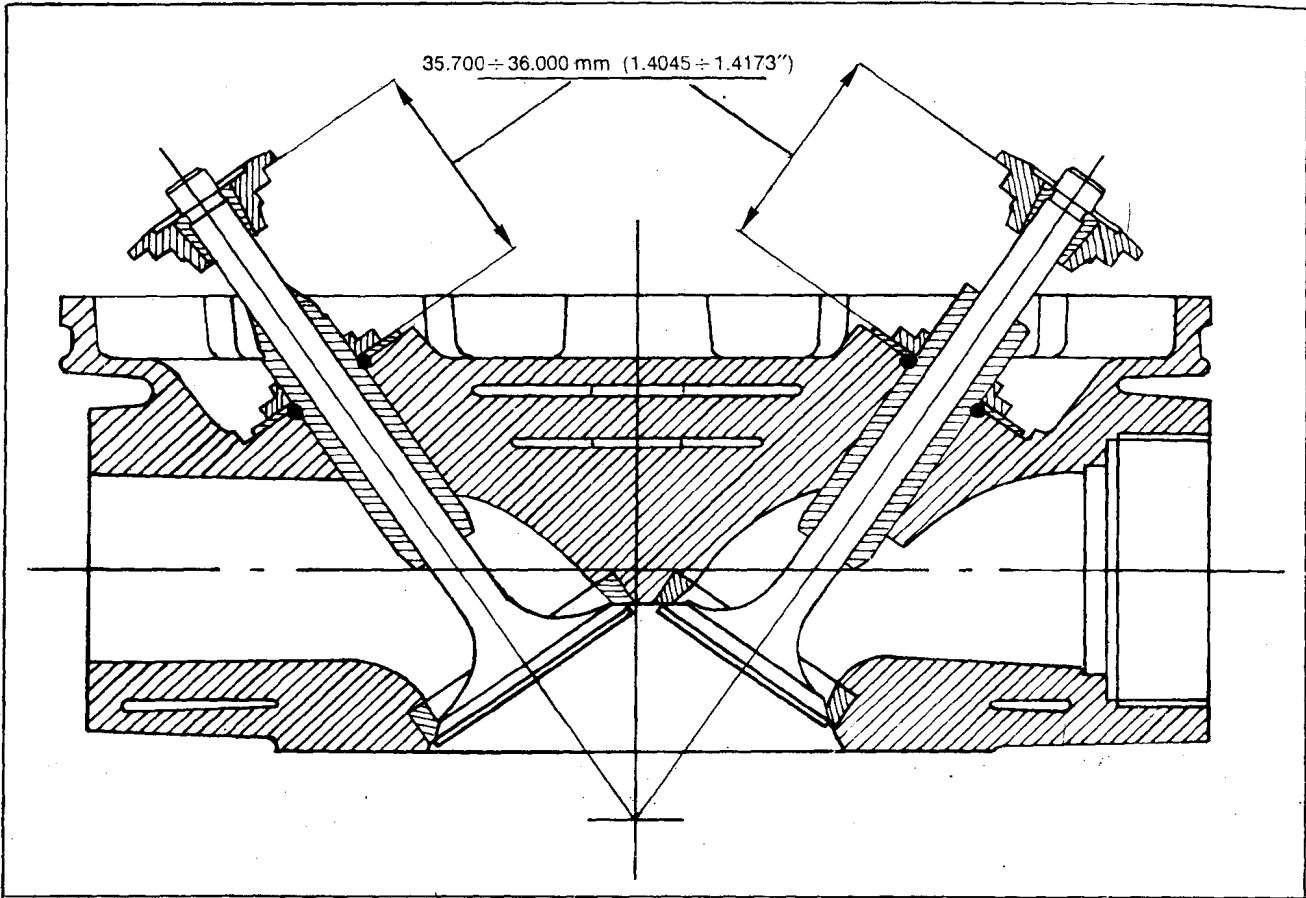

12.7 CHECKING THE INLET AND EXHAUST VALVE OPENING (fig. 47)

After refacing the valve seats, after assembling the valve spring, it is well to ensure that the valve spring compression is in between 35.7-36 mm (1.405-1.417"). When fully stretched the spring should still have a run of 1-1.75 mm (.039-.068") before the outer spring compresses fully.

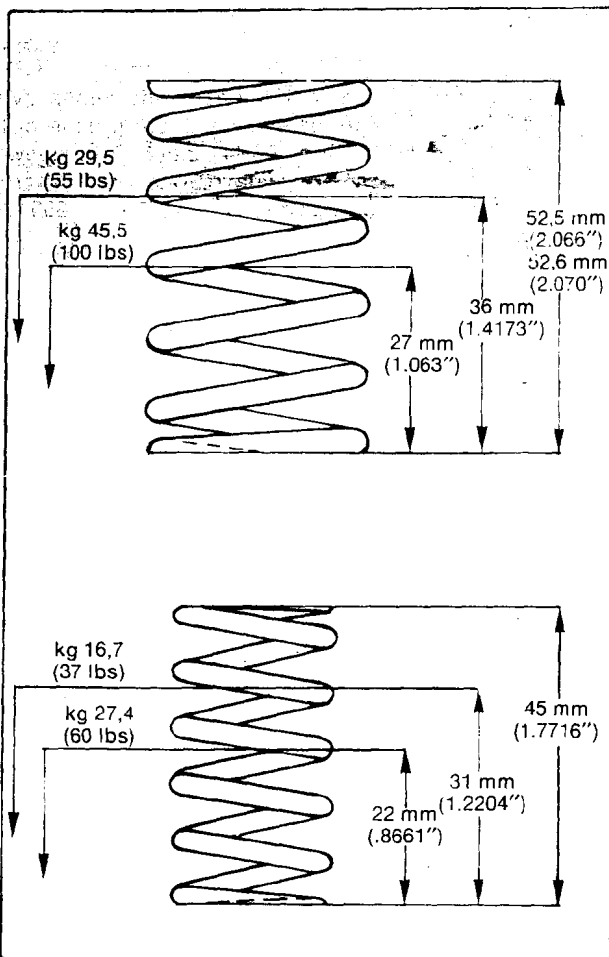

12.8 INSPECTING THE VALVE SPRINGS (fig. 48)

Ensure the springs are not deformed or have lost their load. Spring details:

Outer spring

- free length: 52.5-52.6 mm (2.06-2.07");
- with valve closed: length 36 mm (1.417") - load 29.5 ± 3% kg (abt. 65 lbs);
- Open valve: 27 mm (1.06") - Load 45,5 kg ± 3% (100 lbs).
- fully compressed: 22.75-23.25 mm (.895-.915").

Inner spring

- free length: 45 mm (1.77").
- valve-closed: 31 mm (1.22") - load 16.7 ± 3% kg (37 lbs ± 3%).
- Open valve: 22 mm (.866") - Load 27,4 ± 3% (61-62 lbs).

Fully compressed: 19.75-20.25 mm. long (.778-.794).
If the springs are shorter than above or have a lower load, replace them.

12.9 REFITTING THE VALVE SPRING ASSEMBLY ON THE CYLINDER HEADS

- insert the valve in its guide;
 - on the valve stem fit;
 - adjusting shims, if necessary;
 - bottom collar;
 - inner spring;
 - outer spring;
 - top collar;
 - fit tool 10 90 72 00 (12 in fig. 46) on the top collar and at the center of the valve head. Screw in the tool until both collets can be mounted.
- Remove tool and proceed likewise for the other valve.

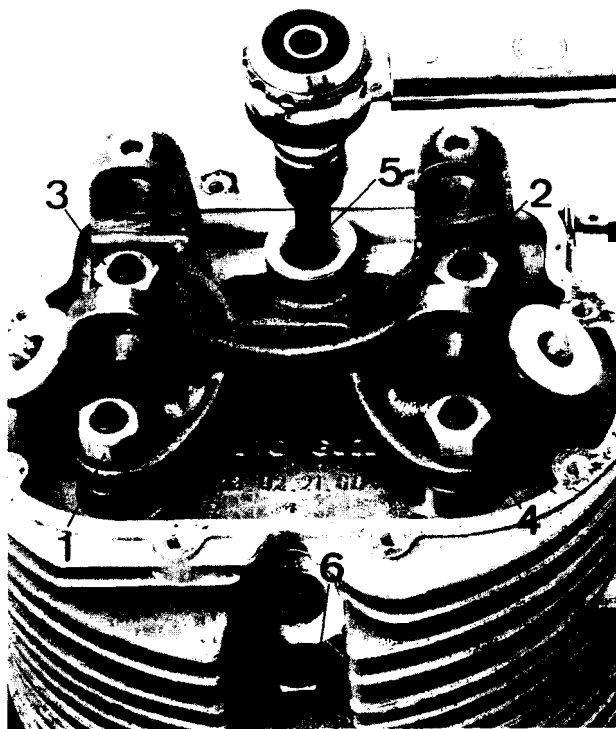

12.10 ASSEMBLING THE CYLINDER BARRELS (fig. 55)

Be sure oil passage «A» in the crankcase is in line with the hole in base gasket «B», the hole of cylinder «C» with holes «A» and «B», and the hole of head gasket «D» with holes «A», «B», «C».

Also don't forget to fit seals «E» on the short studs after fitting the cylinder base gasket.

12.11 REFITTING THE CYLINDER HEADS ON THE CYLINDERS

When refitting these (see arrow «A»), ensure that the lubrication hole in the cylinder is lined up with the hole in the gasket (arrow B) and the hole in the cylinder head (arrow «C», fig. 49/1).

Don't forget to tighten the studs and the nuts in a diagonal sequence (1-2-3-4-5-6) and to set the torque wrench at $4 \pm 4,2$ kgm (29-30 lbs), also to change all gaskets and seals.

12.12 CYLINDER BARRELS

Checking wear

The cylinder bore should be measured at 3 different heights, turning the gauge at 90°.

The dial gage has to be previously set to zero on the slip ring (see fig. 50 and drawing fig. 51). Ensure also that all cylinders and pistons are marked with the same letter («A» or «B») as shown by the arrow in fig. 51/1.

Selection of cylinder diameter

GRADING «A»	GRADING «B»
88.000-88.009 mm (3.4645-3.4648")	88.009-88.018 (3.4648-3.4652")

NB - Cylinders must always be matched with pistons of same grading.

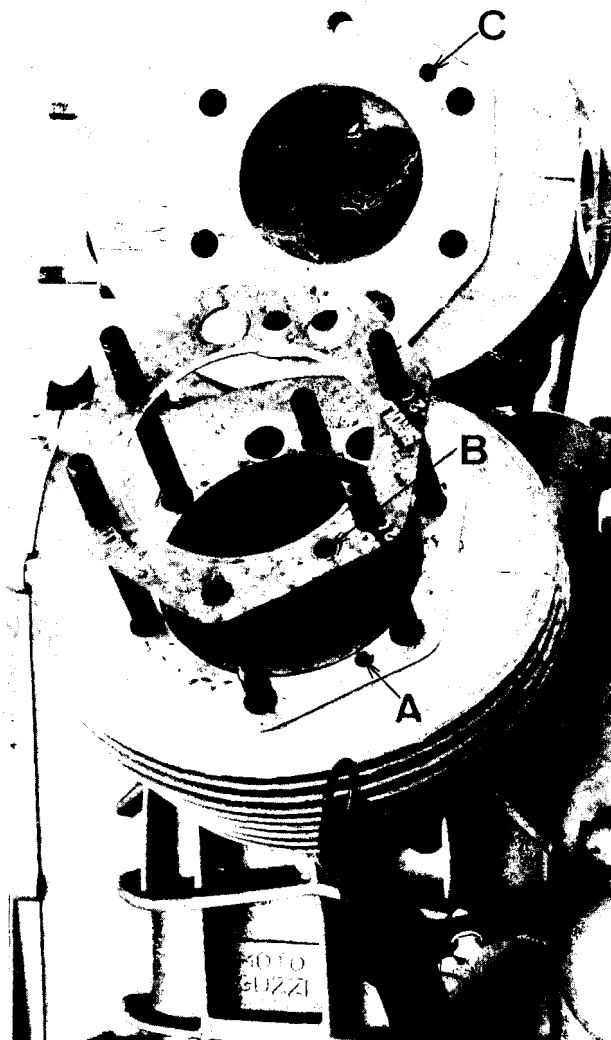

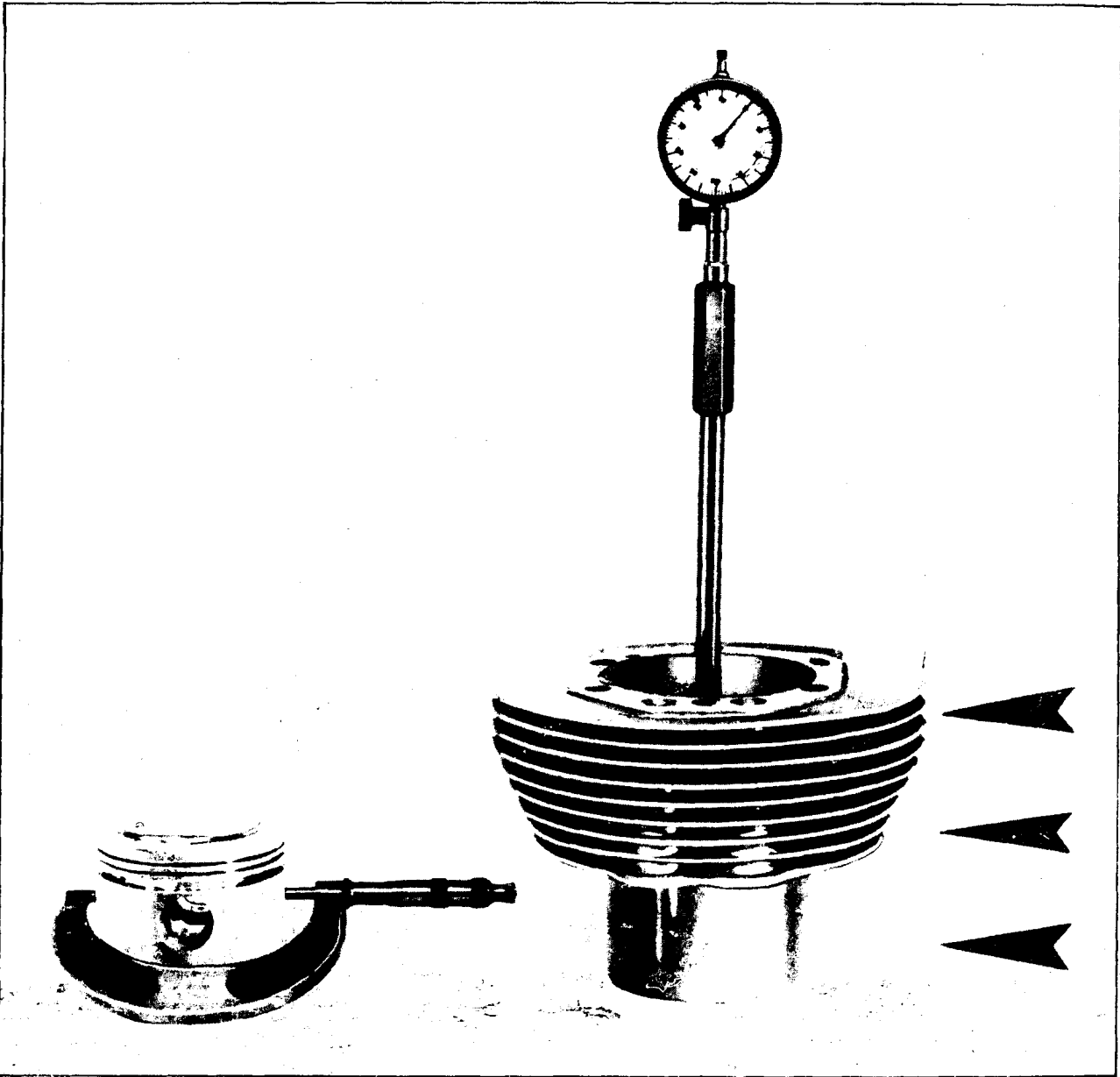

50

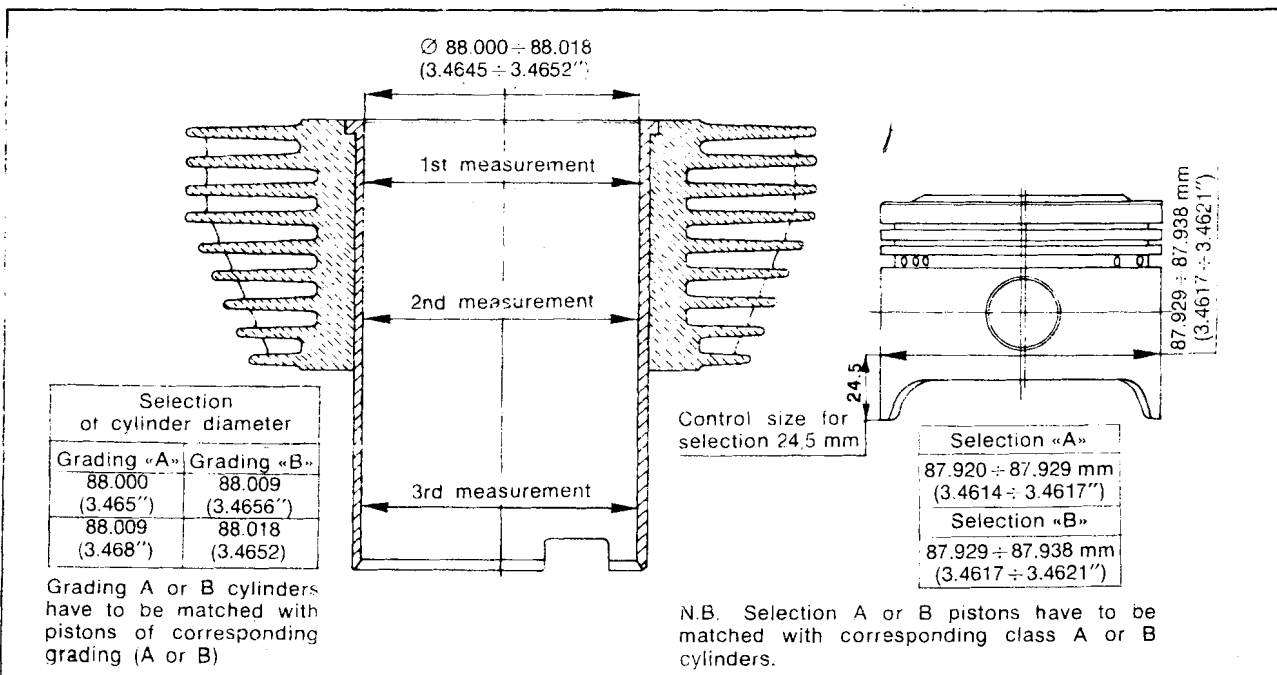

51

Cylinder O/S

2 O/S cylinders are available as spare parts i.e.

- O/S 4/10th mm = dia. 88.400-88.418 mm (3.4800-3.489").
- O/S 6/10th mm = dia. 86.600-88.618 mm (3.4881-3.889").

12.13 PISTONS (fig. 53)

Whenever the engine is overhauled, the piston crown and the piston ring grooves should be cleaned of all carbon deposits before any checking operation is proceeded with.

If the clearance exceeds the indicated limits, it is necessary to change cylinders and pistons.

For proper engine balancing, the piston should be of same weight.

Maximum permissible difference is 1.5 gr (.0502 oz). The selection measurements indicated in the table have to be taken at 22 mm (.866") from the piston base in an orthogonal direction to the piston pin axis.

Maximum permissible ovalization: 0.055-0.065 mm (.0021-.0025") less than the selection sizes.

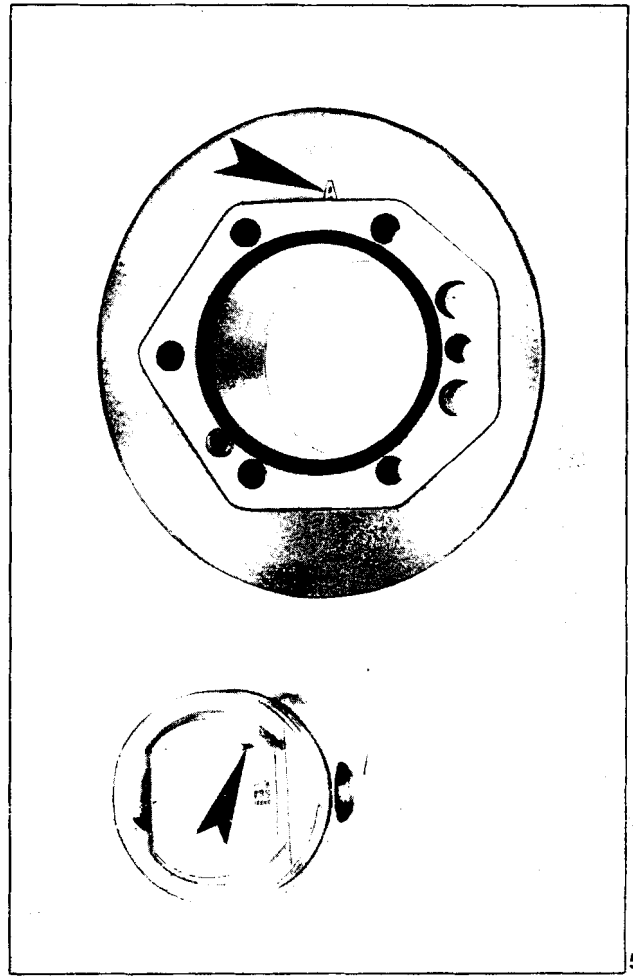

51/1

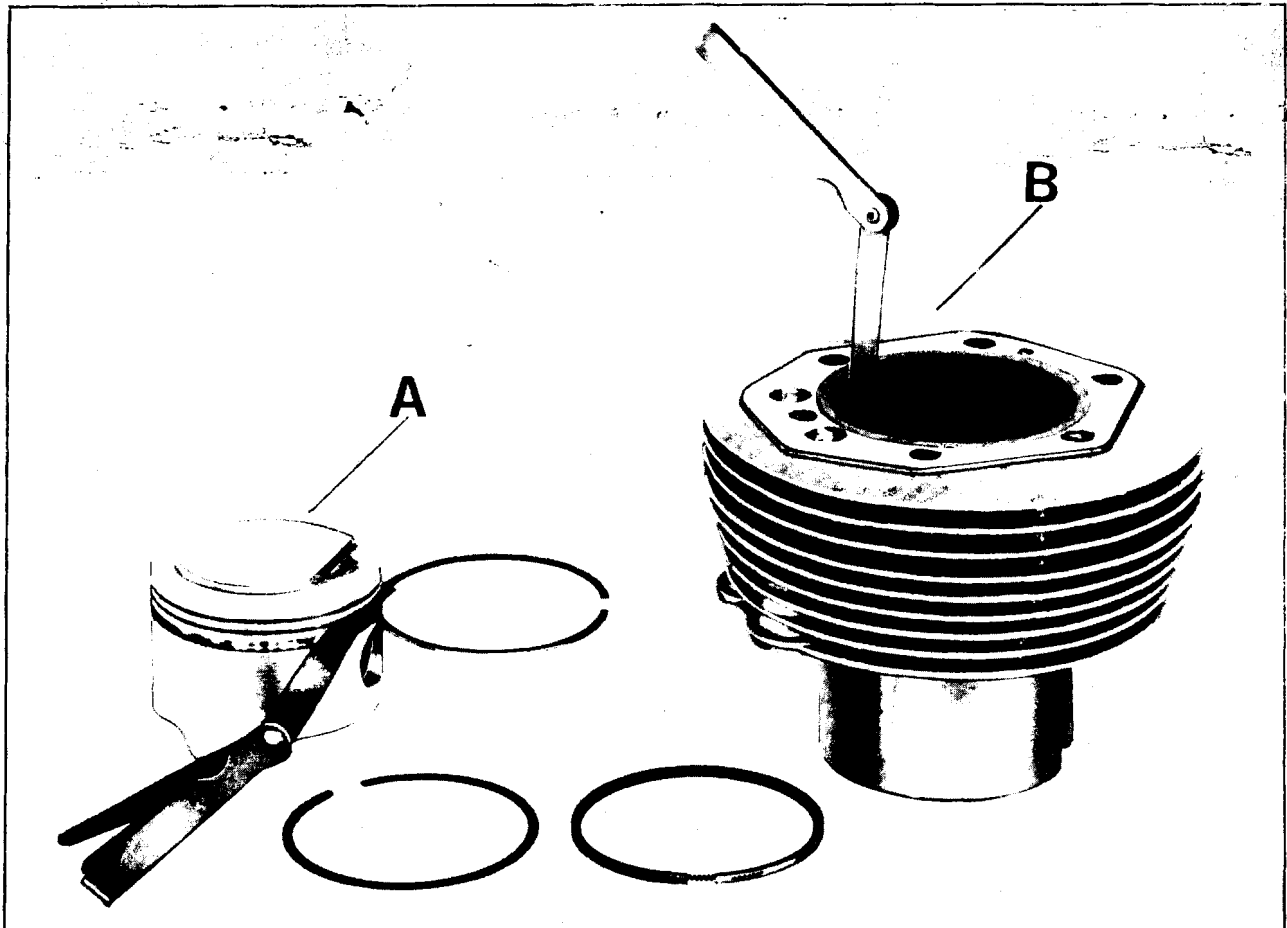

52

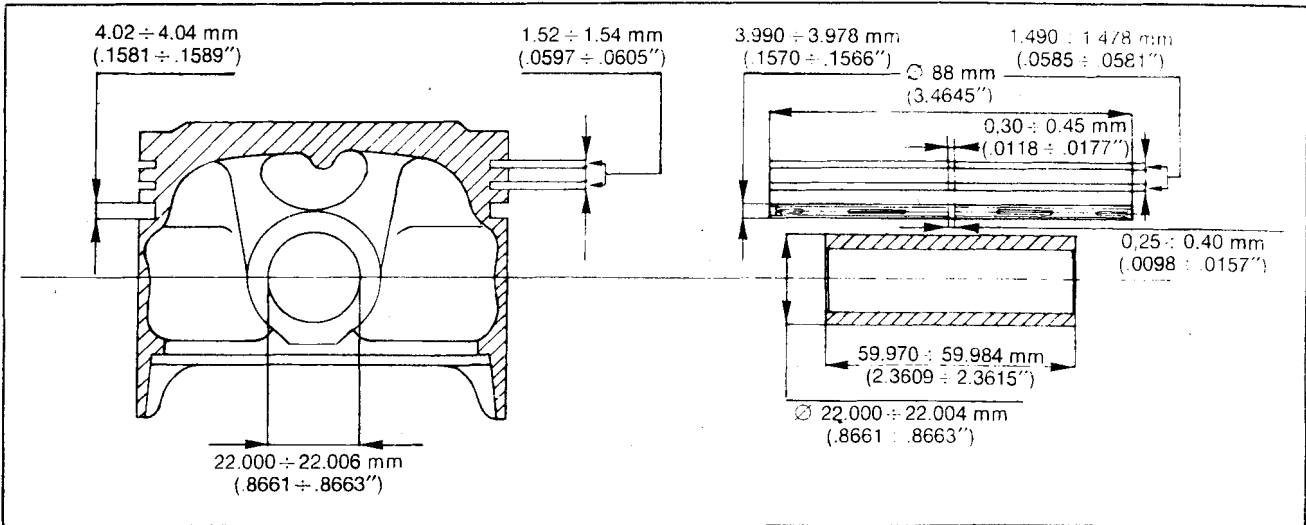

53

Selection of piston diameter

GRADING «A»	GRADING «B»
87,920 ± 87,929 (3.4614'')-(3.4617'')	87,929 ± 87,938 (3.4617'')-(3.4621'')

NB Pistons should always be matched with cylinder of same class. («A» with «A», «B» with «B»).

O/S pistons available as replacement

O/S 4/10 th mm (.015'') = dia. 88.351-88.333 (3.4783-3.4776).

O/S 2/10 th mm (.023'') = dia. 88.551-88.532 (3.4861-3.4854).

Selection diameter should be measured at 24.5 mm (.964'') from the piston base and on an octagonal plane to the piston pin axis. (See fig. 50 and drawing fig. 51).

Fitting the piston on the conrod

To do this, it is necessary to pre-heat the piston in oil in a domestic oven at a temperature of about 60° C (140° F) so as to lightly expand the piston hole to make introduction of the pin easier.

Coupling data

PISTON PIN DIA.	PISTON HOLE DIA.	PISTON PIN-PISTON CLEARANCE AND NEGATIVE ALLOWANCE
22.000 mm (.86614'')	22.000 mm (.86614'')	From 0.006 (.00023'') clearance to a negative allowance of 0.004 mm (.00015)
22.004 mm (.86629'')	22.006 mm (.86637'')	

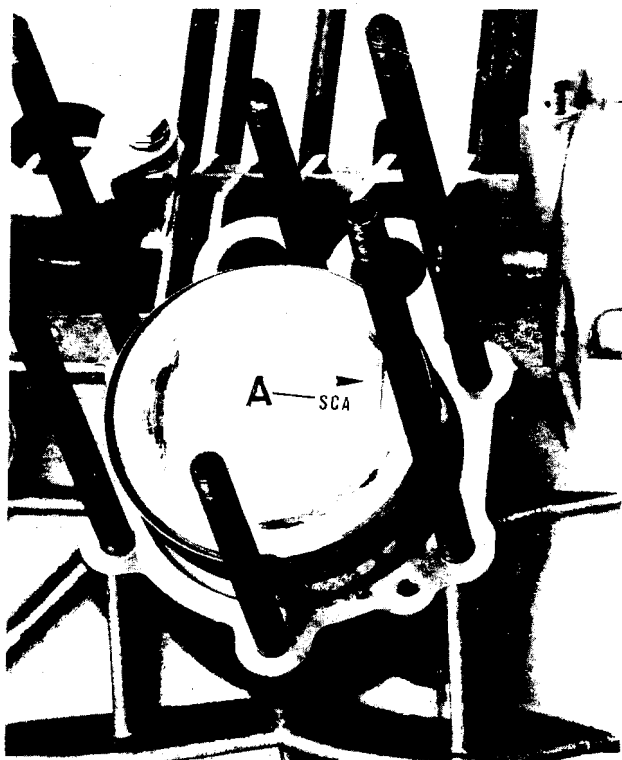

54

12.14 PISTON RINGS AND OIL SCRAPER

Each piston fits 3 rings (2 compression 1 top and 1 center stepped) and 1 oil scraper.

The rings have to be fitted in their slots with the end gap out of line with each other.

Assembly clearance measured between ring thickness and piston groove (see «A» in fig. 52)

Compression ring and oil scraper: 0.030-0.062 mm (.0011-.0024").

Assembly clearance between end gap of ring in the cylinder (see «B» in fig. 52)

Top compression ring and stepped ring: 0.30-0.45 mm (.0118-.0177").

Oil scraper: 0.25-0.40 mm (.0098-.015" - 0.25-0.50 (.0098-.019) for scaper ring w/o spring).

Assembling the piston in the small end (see fig. 54)

On assembly, the piston section marked «SCA» (see arrow «A») should face the exhaust port.

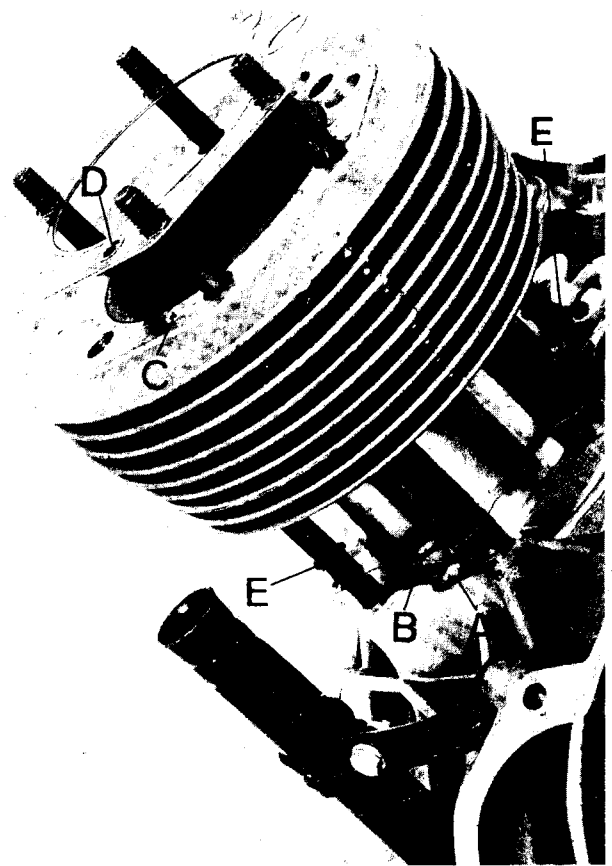

55

12.15 CONNECTING RODS

When overhauling the con-rods, check the following:

- condition of the small end bushings and the bush-piston pin clearance;
- weight of conrods;
- parallelism of axis;
- big end bearings.

The big end bearings are of thin wall type in anti-friction alloy and this does not allow any adjustment. If scored, worn, or seized they must be replaced.

In such a case, the crankpin has to be re-ground.

Before this re-grinding operation is proceeded with, it is necessary to measure the crankpin diameter at the major wear point so as to determine the U/S class of the bearing to be replaced and the diameter to which the crankpin has to be ground.

See table «Thickness of big end bearings» and «crankpin diameter».

Selection

CLASS «A» (BLEU MARK ON STEM)	CLASS «B» (WHITE MARK ON STEM)
47,130 ÷ 47,136 (1.8555")-(1.8557")	47,136 ÷ 47,142 (1.8557")-(1.8560")

Crankshaft-connecting rod selection (see fig. 57 and dwg fig. 58)

Con-rods of class «A» marked «BIANCO» have to be matched with crankshafts of class «B» marked



56

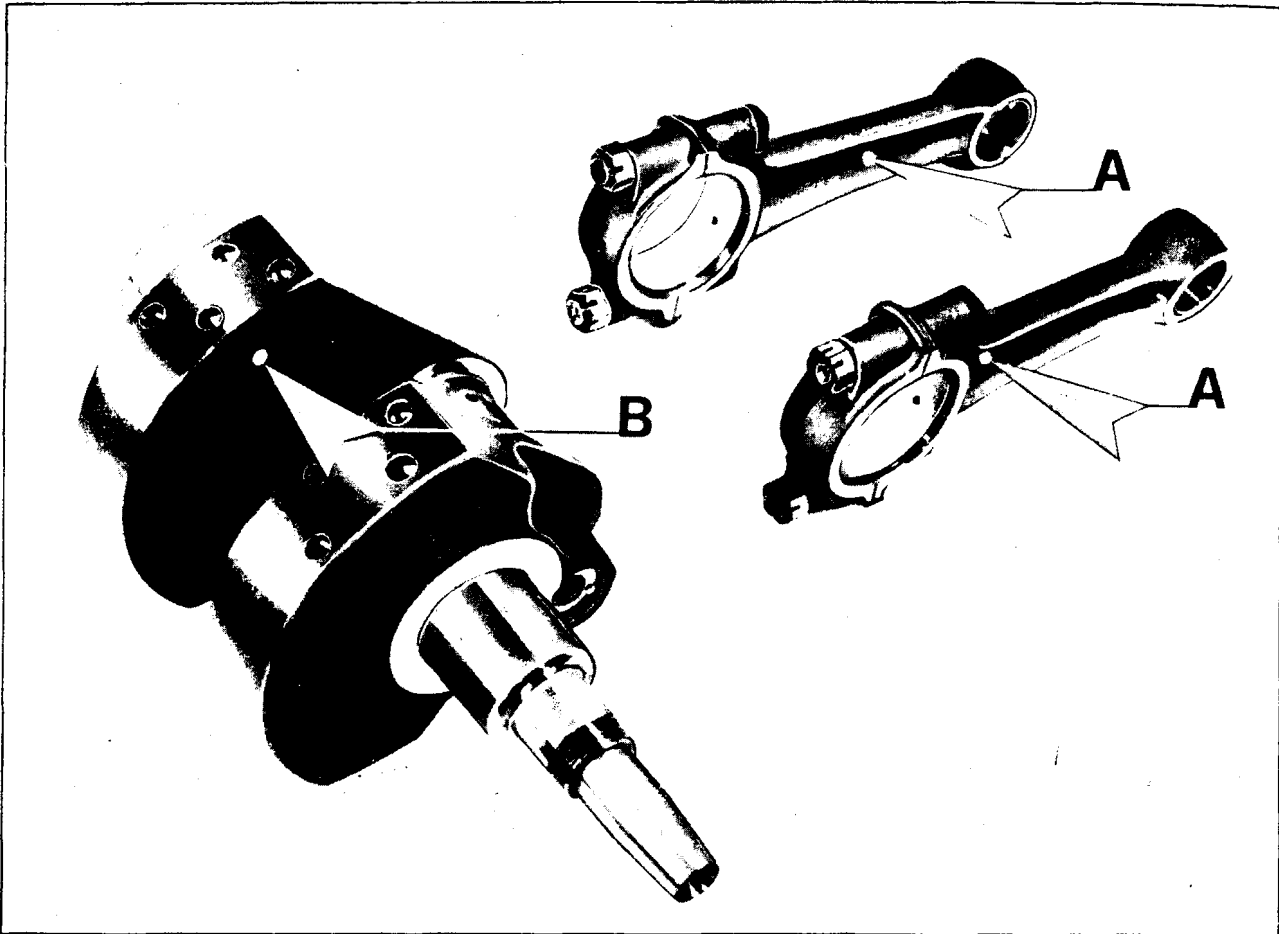

57

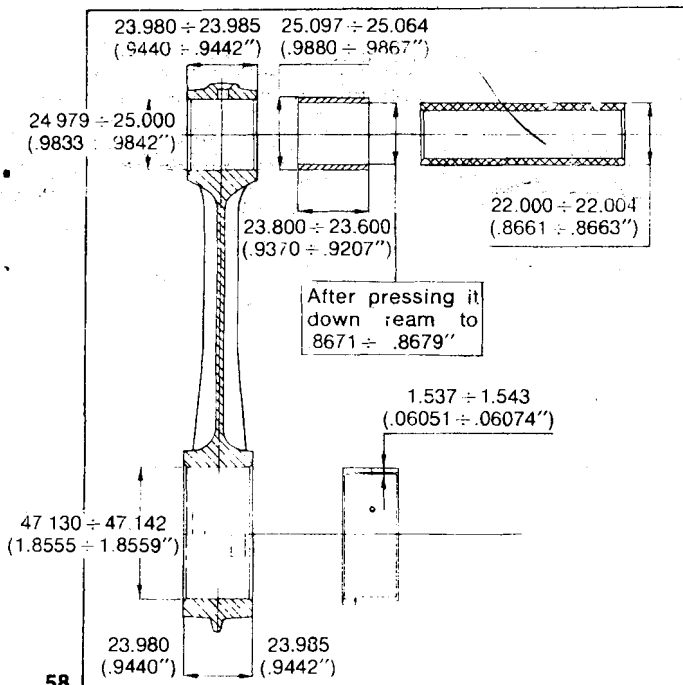

58

«BIANCO», while con-rods «A» marked «AZZURRO» have to be matched with crankshafts «B» marked «AZZURRO».

Small end bushing

If when pressed in, its inner surface should show traces of deep scoring or nicks, it should be replaced.

The damaged bush is removed by the aid of a suitable punch.

When refitting a new bush, ream out its I/D to the sizes indicated in the following tables (fig. 59-59/1).

Thickness of big-end bearings (fig. 58)

ORIGINAL PRODUCTION BEARINGS	0.254 mm (.010'')	OVERSIZE 0.508 mm (.020'')	0.762 mm (.030'')
From 1.537 mm (.06051'') to 1.543 mm (.06074'')	1.664 mm (.06551'') 1.670 mm (.06574'')	1.791 (.0705'') 1.797 (.0707'')	1.918 (.0755'') 1.924 (.0757'')

Crankpin diameter - classes «A» and «B» (see fig. 57 and drawing fig. 63)

GRADING	ORIGINAL DIAMETER	U/S 0.254 mm (.010")	U/S 0.508 mm (.020")	U/S 0.762 mm (.030")
Class «A» Blue mark on shoulder, drive side	44.008-44.014 mm (1.7326-1.7328")	43.754-43.766 (1.7225-1.723")	43.500-43.512 (1.712-1.7130")	43.246-43.258 mm (1.7025-1.7030")
Class «B» White mark on shoulder, drive side	44.014-44.020 mm (1.7328-1.7331")			

Bushing-piston pin clearance

I/D OF BUSHING AFTER PRESSING IN AND REAMING	PISTON PIN DIAMETER	PIN-BUSHING CLEARANCE
22.025 ÷ 22.045 mm (.8671 ÷ .8678")	22.000 (.86614") 22.004 (.86629")	0.021-0.045 mm (.00083-.0017")

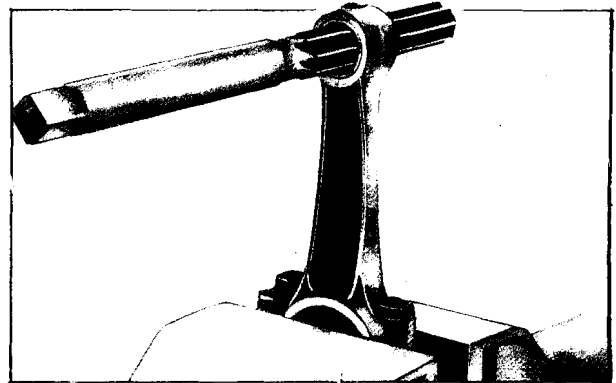

59

Checking parallelism of axis

Before checking the con-rods, ensure that they are «square» or in other words that the big and small ends are parallel to each other.

Any eventual deformation can be rectified by means of a fork lever, forcing on the con-rod stem.

Maximum permissible offset of the small and big end axis, as measured at a distance of 200 mm (7.876") should be ± 0.10 mm (.0039"-fig. 60).

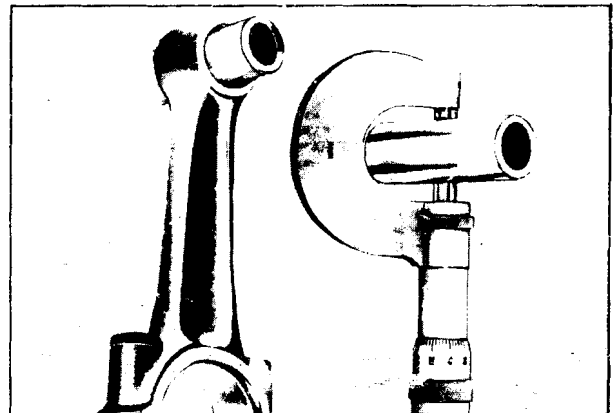

59/1

12.16 FITTING THE CON-RODS ON CRANKSHAFT

Bearing-crank pin clearance on assembly goes from a minimum of 0.050 mm (.0019") to a maximum of 0.085 mm (.0032"). See dwg fig. 58.

Con-rod-crankshaft clearance is 0.30-0.50 mm (.011-.019). See fig. 62.

Fit the con-rod on the crankshaft and tighten the nuts using a torque wrench loaded to 4.6-4.8 kgm (33-35 ft. lbs). (See fig. 64).

Fig. 65 shows the dismantled con-rod assembly. For measurements see fig. 58.

NB Looking at the engine from the clutch side, the milled surfaces of the con-rods and caps have to be on the same side («B» in fig. 61).

12.17 CRANKSHAFT

Check crankpin surfaces. If deeply scored or ovalized, the crankpin should be re-ground to any of the

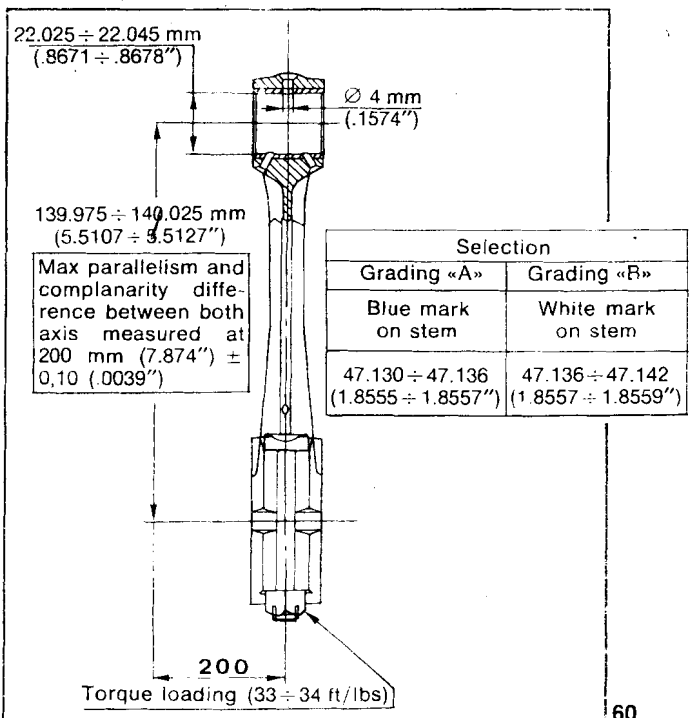

60

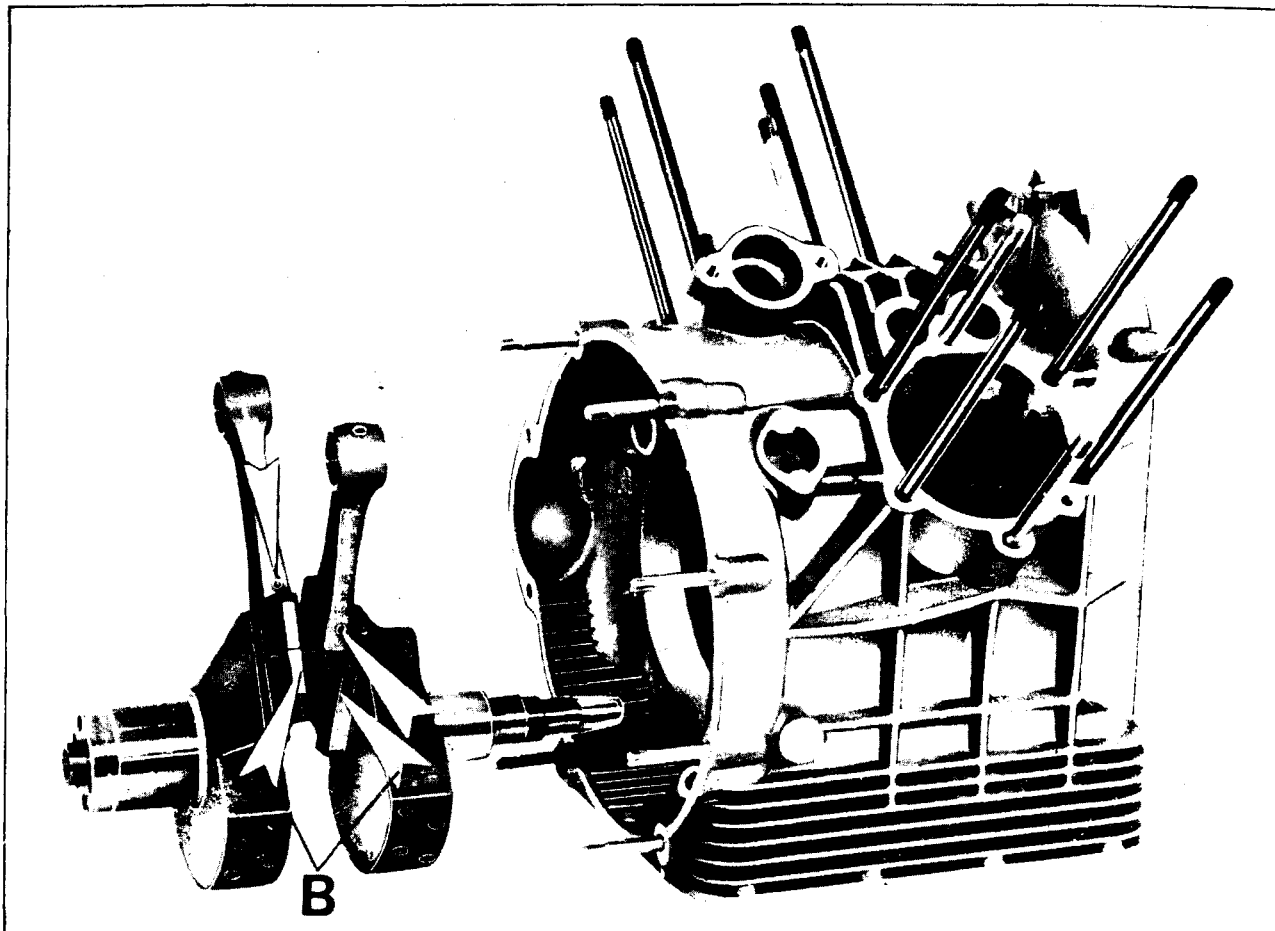

sizes indicated in the table and fitted with appropriate u/s bearings (see table).

The undersize range of big end bearings available is 0.2-0.4-0.6 mm (.00787-.01574-.02363") See table.

Big end bearings are supplied in the following oversizes:

0.254-0.508-0.762 mm (.010-.020-.030") (see table)

Before re-grinding, it is necessary to carefully determine the amount of wear of the crankpin (see fig. 56-66-67 and dimension drawing fig. 63) so as to decide the new diameter, taking into account the available sizes and the necessary clearances

Original clearances on assembly are:

- Main journal-bearing timing side 0.028-0.060 mm (.0011-.0023")
- Main journal-big end bearing, drive side 0.040-0.075 mm (.0015-.0029")
- Crankpin-bearing 0.030-0.054 mm (.0011-.0021")

When re-grinding the crankpin, do not forget to leave amount to the shoulder relief radius which is 2-2.5 mm (.078-.098") for the crankpin and 3 mm (.118") for the journal drive side and 1.5-1.8 mm (.058-.070") for the journal, timing side.

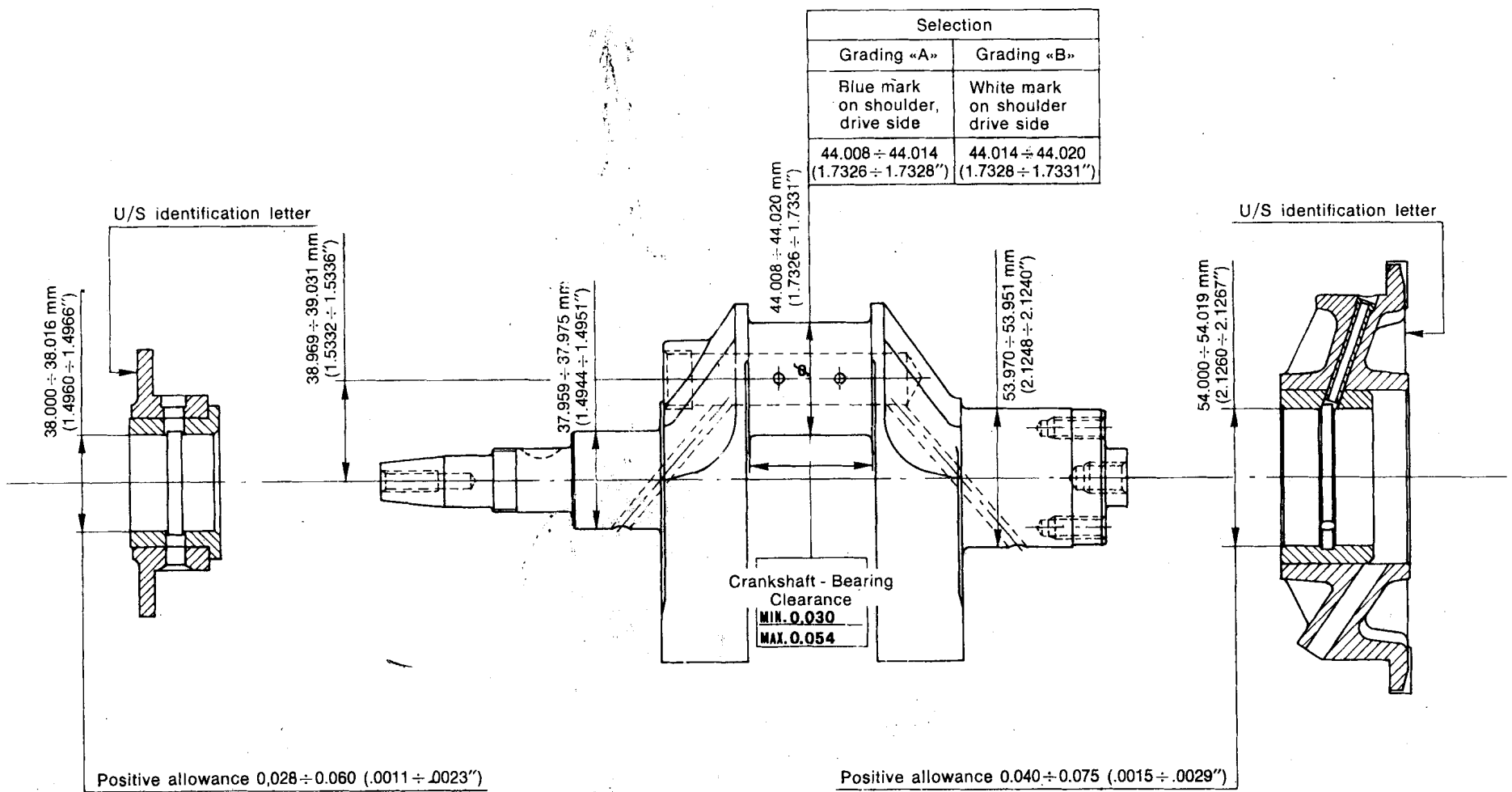

Mainshaft diameter, drive side

ORIGINAL PRODUCTION	UNDERSIZE		
	0.2 mm (.0078")	0.4 mm (.01574")	0.6 mm (.02362")
53.970 mm (2.1248")	53.770 (2.1169")	53.570 (2.1090")	53.370 (2.1011")
53.951 mm (2.1240")	53.751 (2.1162")	53.551 (2.1083")	53.351 (2.1004")

Mainshaft diameter, timing side

ORIGINAL PRODUCTION	UNDERSIZE		
	0.2 mm (.0078")	0.4 mm (.01574")	0.6 mm (.02362")
37.975 (1.4951")	37.775 (1.4872")	37.575 (1.4793")	37.375 (1.4715")
37.959 (1.4944")	37.759 (1.4866")	37.559 (1.4787")	37.359 (1.4707")

12.18 CHECKING WEIGHT FOR ENGINE BALANCING

The con-rods complete with nuts and bolts should be of same weight. Max permissible difference: 3 grams.

The crankshaft is statically balanced by adding a weight of 1.650-1.680 kg (3.6-3.99 lbs).

12.19 FITTING THE FLYWHEEL ON THE CRANKSHAFT (fig. 68 and 68/1)

When fitting the flywheel on the crankshaft, ensure that the mark on the shaft (see arrow «A») is in line with the TDC mark on the flywheel (see arrow «B» - fig. 68 1).

Fit the flywheel using tool N. 12 91 18 01 (21 fig. 41) and tighten to a load setting of 4.2 kg (30 ft/lbs).

If the crankshaft needs replacing and there is no «A» mark on it, it is necessary to paint it on it, ensuring it is in line with the hole at the center of the crankpin and the drive pinion key.

12.20 FLYWHEEL FLANGE COMPLETE WITH MAIN JOURNAL AND PIN

Ensure that the union faces of the crankcase are perfectly smooth, with no scoring marks or nicks, also the main bearing is not excessively worn (see table «I-D of journal, drive side»).

In fitting it on the crankcase, ensure oil passage «A» is in line with oil passage «B» in the crankcase (fig. 69) and that tool N. 12 91 20 00 (24 in fig. 70) and 14 92 71 00 (16 in fig. 70) are set up on the crankshaft.

This will allow the flange seal to be fitted on the shaft without damaging its inner surface.

64

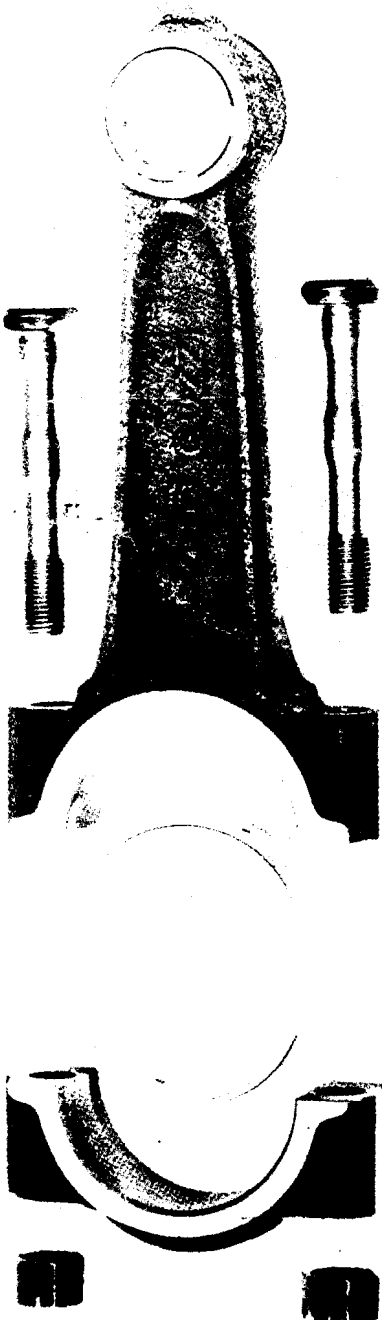
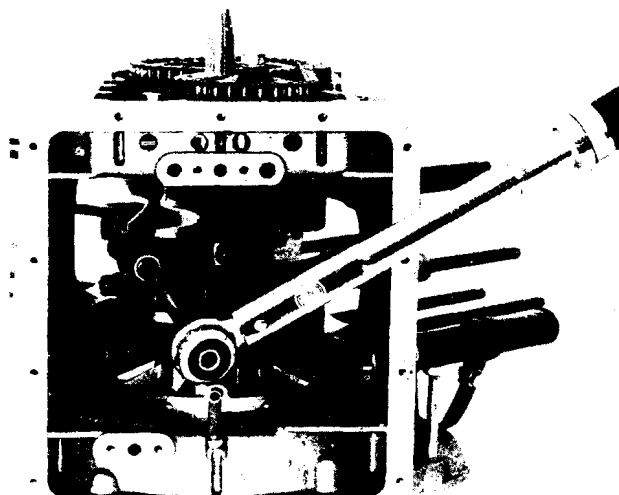

65

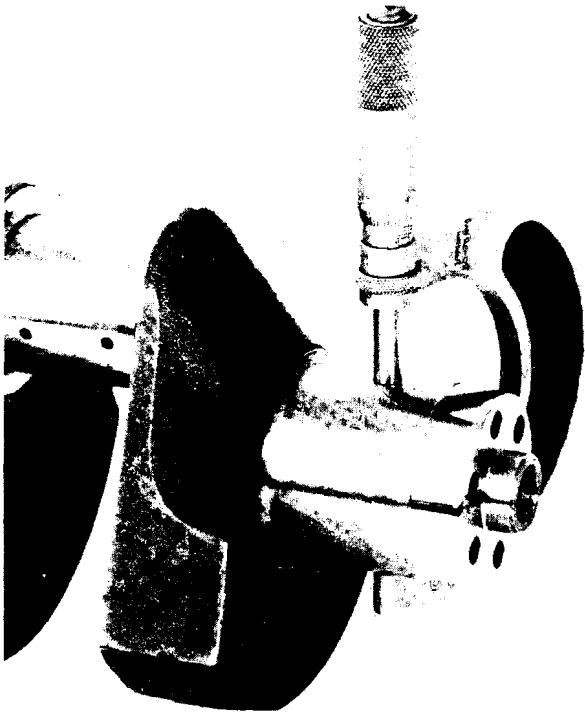

66

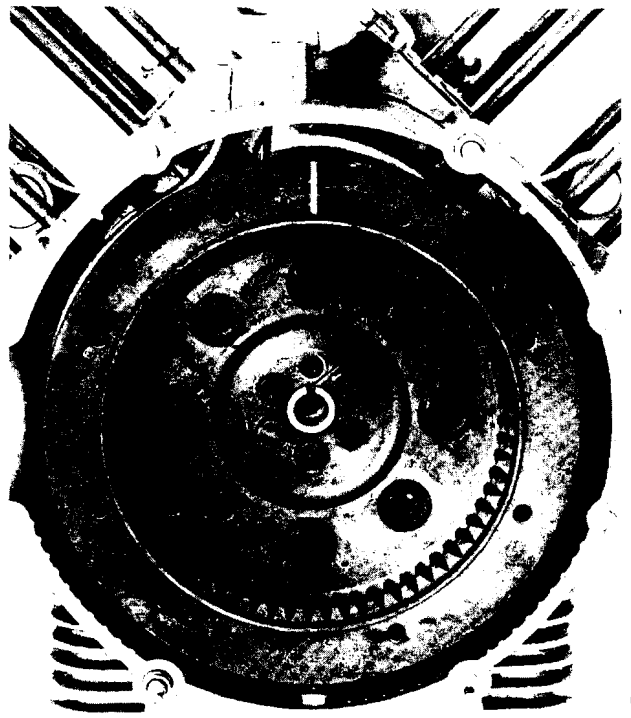

68 1

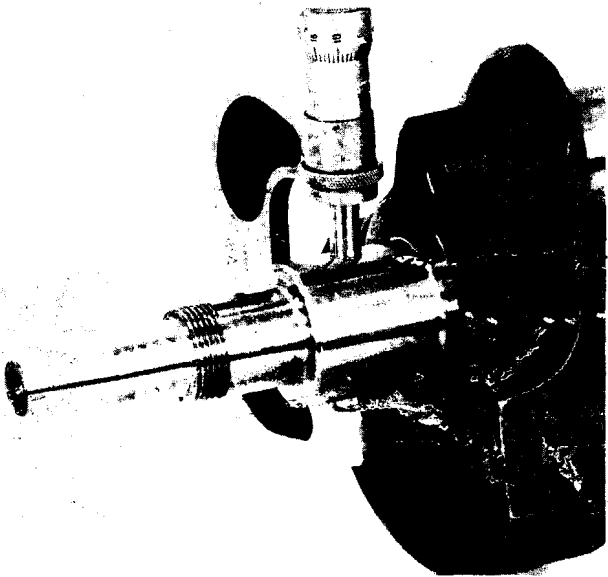

67

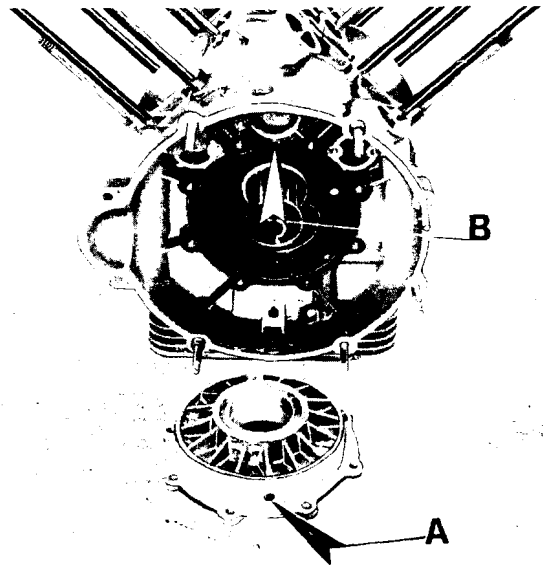

69

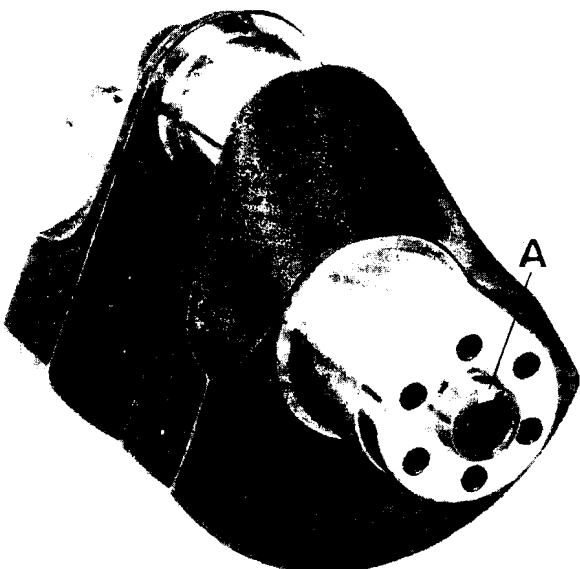

68

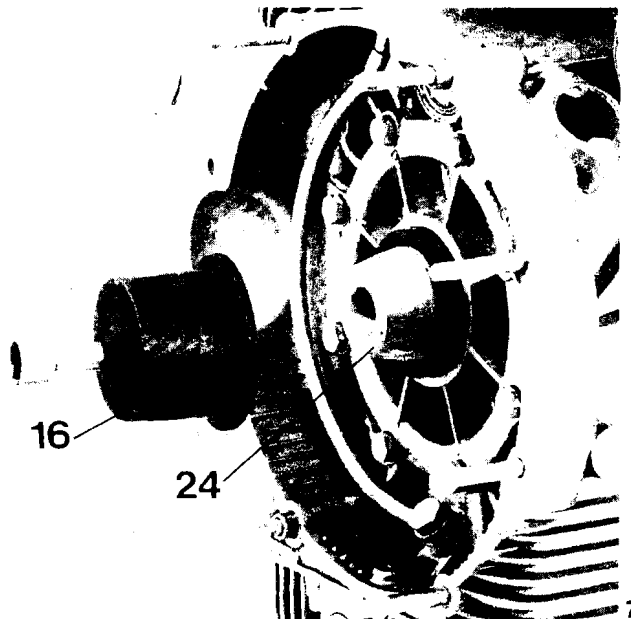

70

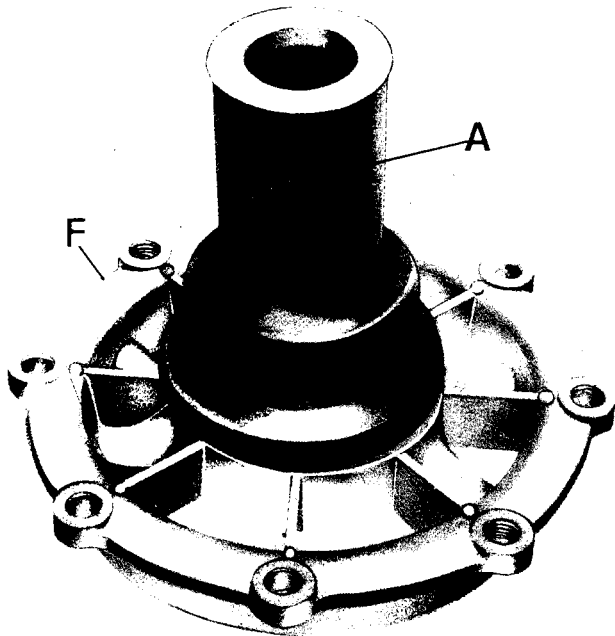

71

12.21 SEAL FOR FLANGE, DRIVE SIDE

When overhauling, ensure this seal is properly pressed into the flange and that its internal surface working on the crankshaft is not crumbled or damaged. If so, replace the seal.

Fitting the seal on the flange, «F» drive side

This is done using tool N.14 92 71 00 («A» in fig. 71).

12.22 FITTING THE FLANGE COMPLETE WITH MAIN BEARING IN THE CRANKCASE DRIVING SIDE (fig. 72)

In fitting this flange in the crankcase, ensure oil duct «A» is in line with the hole in crankcase «B».

Fit the chain tensioner, bearing in mind that the spacers are placed between crankcase and tensioner. From the drive side insert the crankshaft in the flange, timing side.

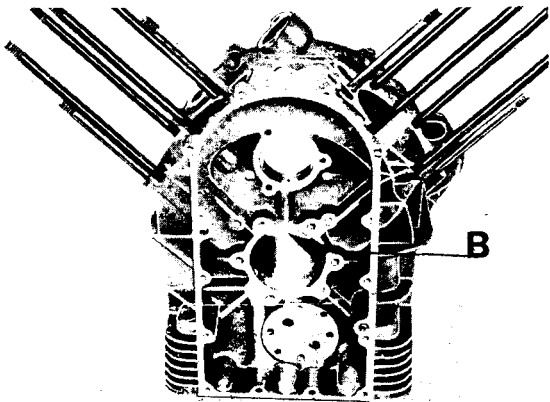

72

12.23 ASSEMBLING THE SEAL ON TIMING COVER

Use tool part N. 14 92 72 00 (17 in fig. 73).

Crankcase

Make sure that all joining faces with the covers and sump are perfectly smooth, also that the tappet seats are undamaged. If so, ream out with a drift (fig. 74) to 1st or 2nd undersize, as specified in the table.

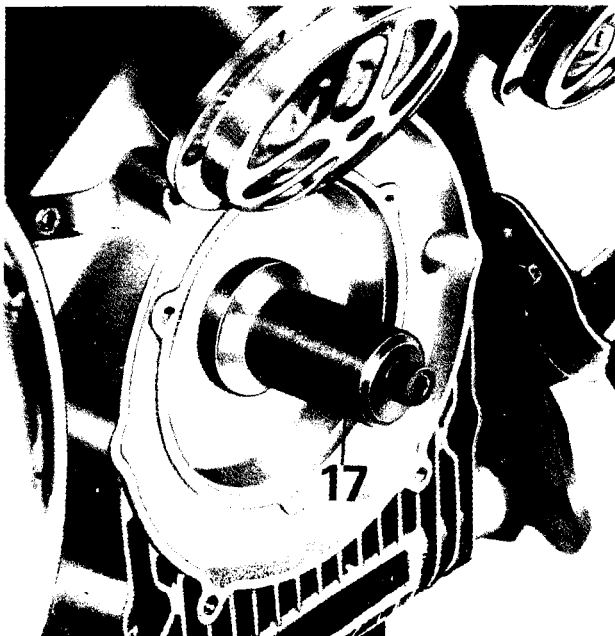
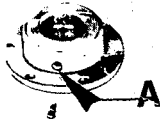

73

12.24 CHECKING OIL LEAKAGES FROM THE CRANKCASE - FLANGE DRIVE SIDE

In case of any oil leakage from the engine unit check the following:

- Condition of seal in the flange, drive side.
- Condition of the crankshaft section contacted by the seal. It should be perfectly smooth.
- If there are any blowholes in the crankcase. Do this by setting up the engine on a bench with the drive side turned upwards (see fig. 75) and after removing the flywheel from the crankshaft.
- Put some engine oil on the flange seal, drive side.
- Fill the crankcase with water.
- Using a rubber hose with suitable clips, plug up a breather tube.
- Blow compressed air through the other tube, keeping a hold on the seal with 2 fingers (see fig. 75).
- The presence of any porosity will be evidenced by air bubbles. In such case, plug up hole with cement compound Devcon F part n. 00 01 02 00 (57 fig. 35).

Prior to carrying out the above operation, ensure that:

- The clips closing the rubber hose of the breather are not slack.
- It is possible that some oil may flow into the hoses and metal pipes and finish up between gearbox and engine.
- Both the bottom bolts securing the flange, drive side to the crankcase and the breather line cap screw are dry. If oiled, place some Teflon tape on the threaded part of the bolts.
- The bottom stud securing the gearbox to the engine on the L/H side, i.e. where the reference bush is mounted is not oiled. If so place some Teflon tape on the bolt thread.

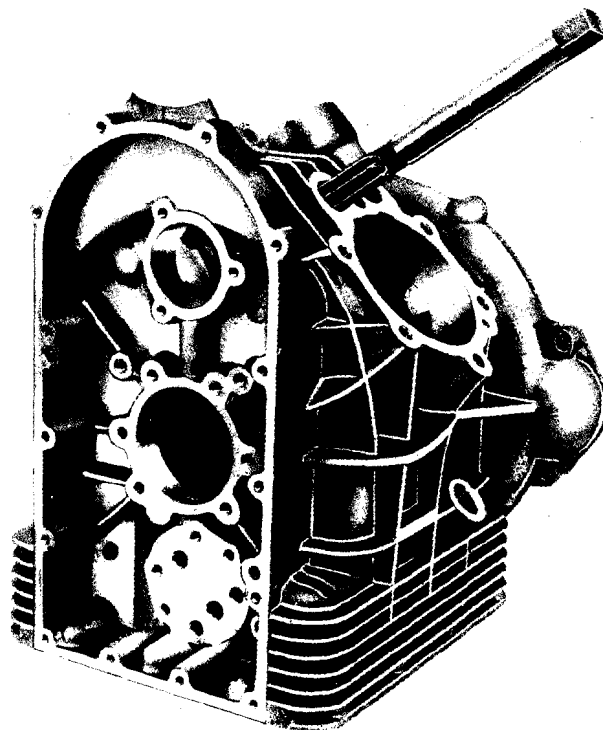

74

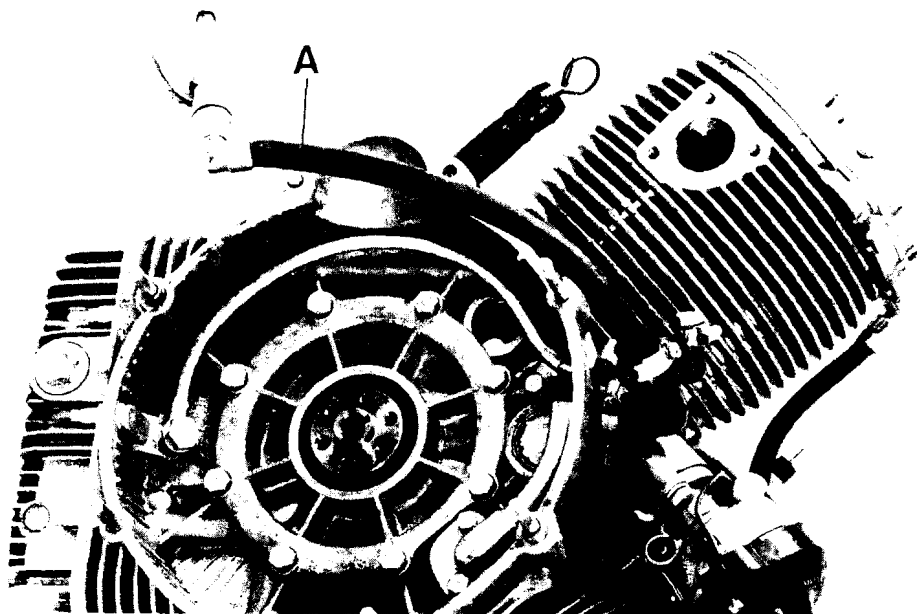

75

13 TIMING

13.1 Timing data (applicable to a rocker clearance of 1.5 mm (.0059")) are (see fig. 76):

Inlet

- open 20° before TDC
- closes 52° after BDC

Exhaust

- opens 52° before BDC
- closes 20° after TDC

Normal rocker clearance (cold engine): 0.22 mm (.00866").

76

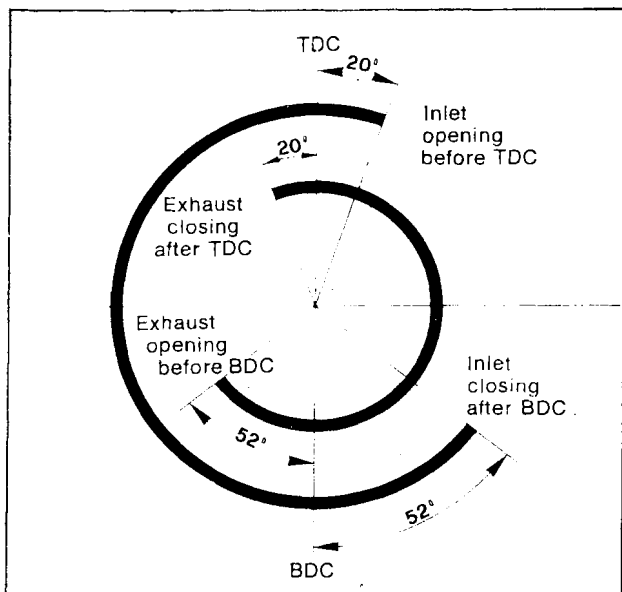

13.2 DIAMETER OF CAMSHAFT BEARINGS AND THEIR HOUSINGS IN CRANKCASE

	CAMSHAFT JOURNAL	HOUSING IN CRANKCASE	FITTING CLEARANCE
Timing side	47.000-46.984 (1.850-1.849")	47.025-47.050 (1.8511-1.8523")	0.025-0.066 mm (.0009-.0026")
Drive side	32.000-31.984 (1.2598-1.2592")	32.025-32.050 (1.268-2.617")	

13.3 TAPPET-GUIDE IN CRANKCASE - COUPLING DATA

	I/D OF GUIDE HOUSING	O/D OF TAPPETS	FITTING CLEARANCE
Original	22.021-22.000 mm (.8669-.8661")	21.996-21.978 mm (.8659-.8647")	0.004-0.043 mm (.00015-.00169")
O/S on dia. 0.05 mm (.0019")	22.071-22.050 (.8686-.8670")	22.046-22.028 (.8678-.8639")	0.004-0.043 mm (.00015-.00169")
0.10 mm (.0039")	22.121-22.100 (.8708-.8700")	22.096-22.078 (.8698-.8691")	0.004-0.043 mm (.00015-.00169")

13.4 ASSEMBLING THE CAMSHAFT ASSEMBLY, GEARS WITH CHAIN ON SHAFTS: ENGINE, TIMING, OIL PUMP

After mounting the oil pump and the chain tensioning group, proceed as follows:

- Introduce camshaft «A» complete with pin in the crankcase housings and secure the shaft with flange «B» by tightening screws with washers «C» (fig. 77).
- Insert the gear set with chain «D» on the shafts: cams, engine, and oil pump, lining up reference marks «E» which indicate the engine is in the timing phase (see fig. 77).
- Lock the gear retaining nut on the camshaft with circlip «L» (fig. 77) using special holdfast tool part N 12 91 18 01 (21 in fig. 35) and a torque wrench set to 15 kgm (87 ft lbs).

- Lock the engine sprocket retaining ring with lockplate «M» using tool 12 91 18 01 (21 in fig. 79 and special wrench 18 92 76 50 (54 in fig. 79). Fold down the lockplate flaps in one of the locking ring grooves with a center punch.

- Secure the oil pump gear retaining nut with circlip «N» (fig. 77), not forgetting to fit key «O» (fig. 77) using tool 12 91 18 01 (21 in fig. 79/1) and a wrench. At the end of this operation, after tightening the nuts and the timing gear locking, also traced the TDC mark on the crankcase (for this it is necessary to provisionally mount a gear box on the engine and to trace a line on the crankcase from the center of the inspection hole), check that the reference marks on gears «A» (fig. 80) — camshaft driving and engine drive pinion — are perfectly lined up, also that the mark stamped under «S» on the flywheel is in line with the mark traced on the crankcase. Then introduce tappets «Q» (fig. 77) in their housings «P» in the crankcase.

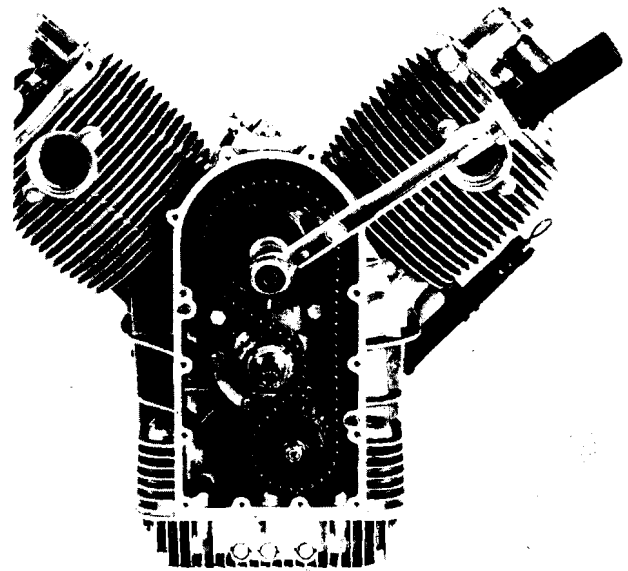

78

13.5 HOW TO REPLACE THE CHAIN AND/OR GEAR ON AN ENGINE ASSEMBLED ON THE FRAME

Proceed similarly as described in 13.4 but instead of using holdfast tool 12 91 18 01 on the flywheel, it is necessary to use camshaft gear holding tool N. 14 92 73 00 (20 in fig. 80/1-80/2-80/3).

13.6 VALVE TIMING

Valve timing is checked as follows:

- 1 Give the tappets a provisional clearance of 1.5 mm (.059").

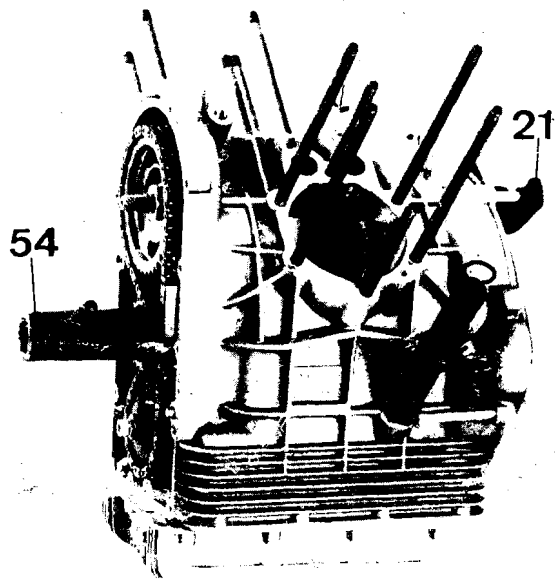

79

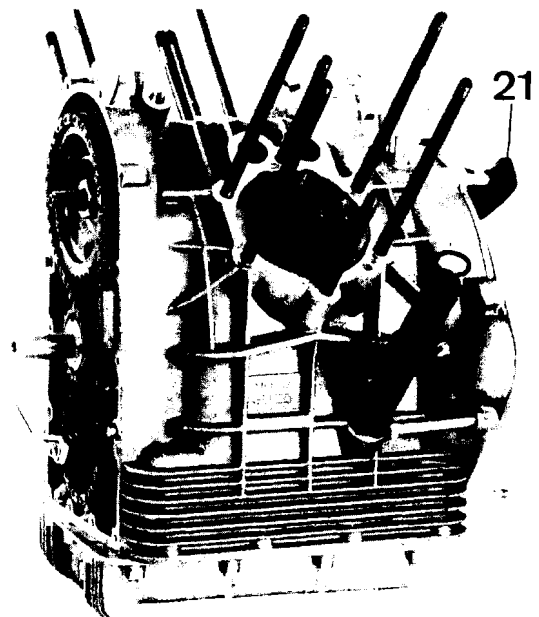

79/1

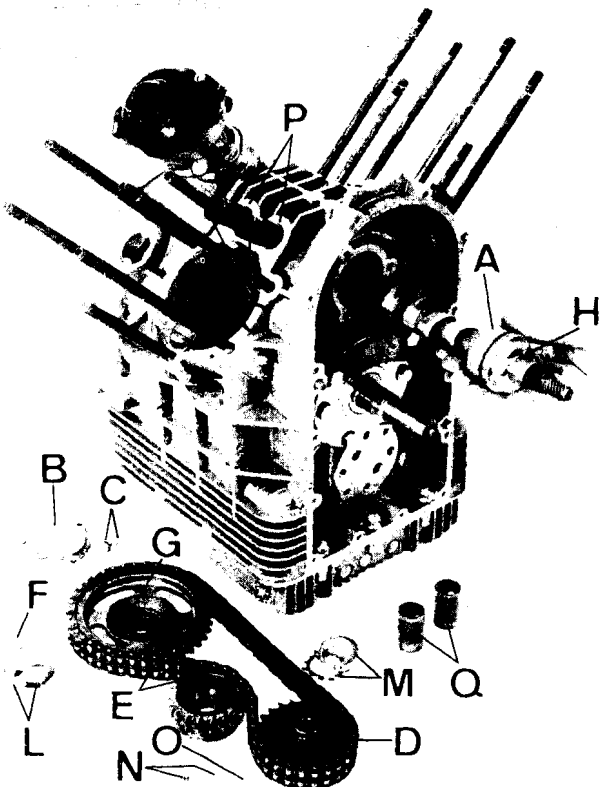

77

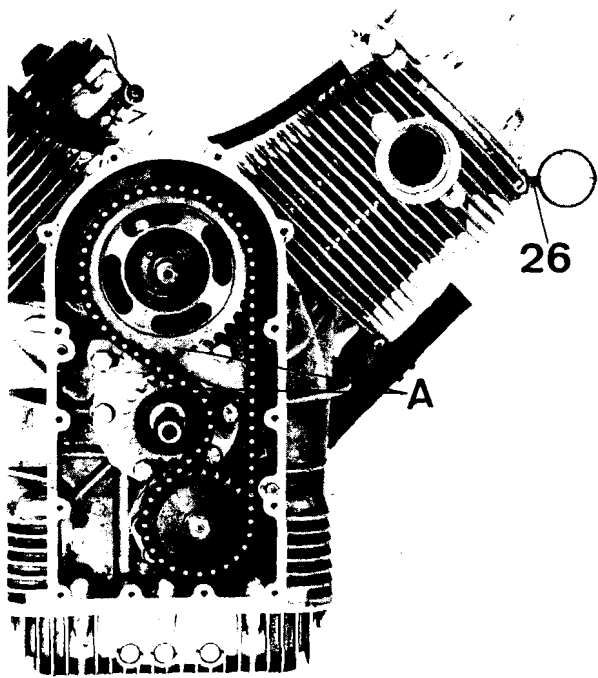

80

- 2 Straighten the flaps of the engine sprocket locking and unscrew the locking.
- 3 In the crankshaft spline introduce hub 17 94 95 60 (25 in fig. 81) securing it with a screw to the crankshaft (with timing plate mounted). N. 19 94 76 60 (2 in fig. 81).
- 4 Secure arrow 17 94 75 60 (3 fig 81) to the threaded hole in the crankcase with a screw.
- 5 On the L/H cylinder plug hole fit comparator support part N. 17 94 82 60 (26 fig. 81) and on this the gage itself.
- 6 Turning the degree plate clockwise until the piston of the L/H cylinder is in the TDC position (valves fully closed), set the dial gage to zero, and ensure that marks «A» (fig. 80) on the timing gear and the engine drive pinion are properly lined up. also that by looking through the inspection hole in the gearbox the small «S» mark is in line with the mark stamped at the center of the inspection hole
- 7 At this stage, line up the point of the arrow with the TDC zero on the degree plate.
- 8 Check timing against the data in the timing diagram.

To check timing of the R/H cylinder:

- 9 Screw the dial gauge support in the R/H cylinder plug hole.
- 10 Set up the control arrow to the right of the crankcase.
- 11 Turn the degree plate clockwise until mark «D» is in line with the center mark of the inspection hole in the gear box (valves closed).
- 12 Proceed in the same way as for the L/H cylinder.

After this control, if all is correct:

- 13 Restore the rocker clearance to 0.22 mm (.0086").
- 14 Remove degree plate from the crankshaft and the arrow from the crankcase.
- 15 Remove the dial gauge support from the R/H cylinder plug hole, refit the spark plugs, and complete the assembly.

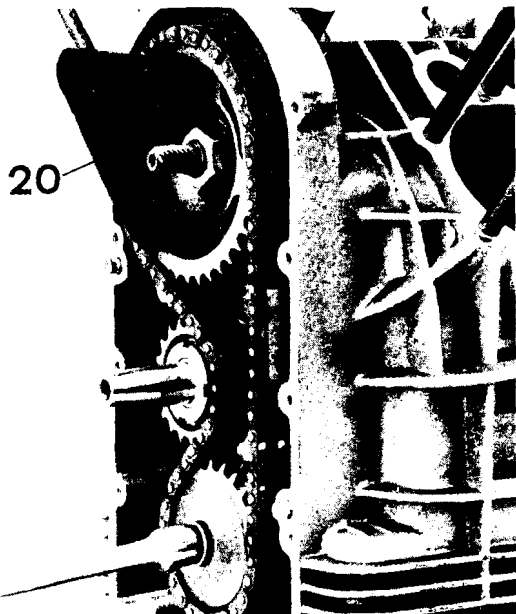

80/1

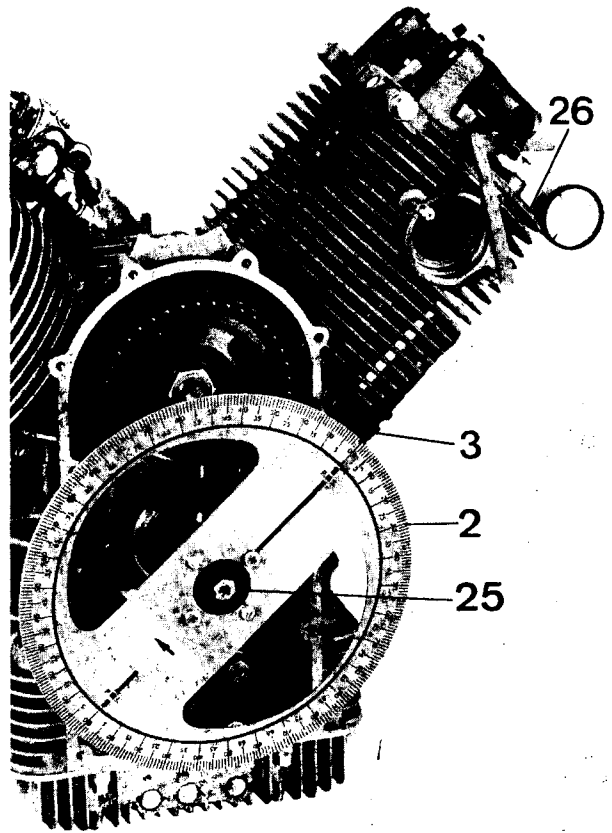
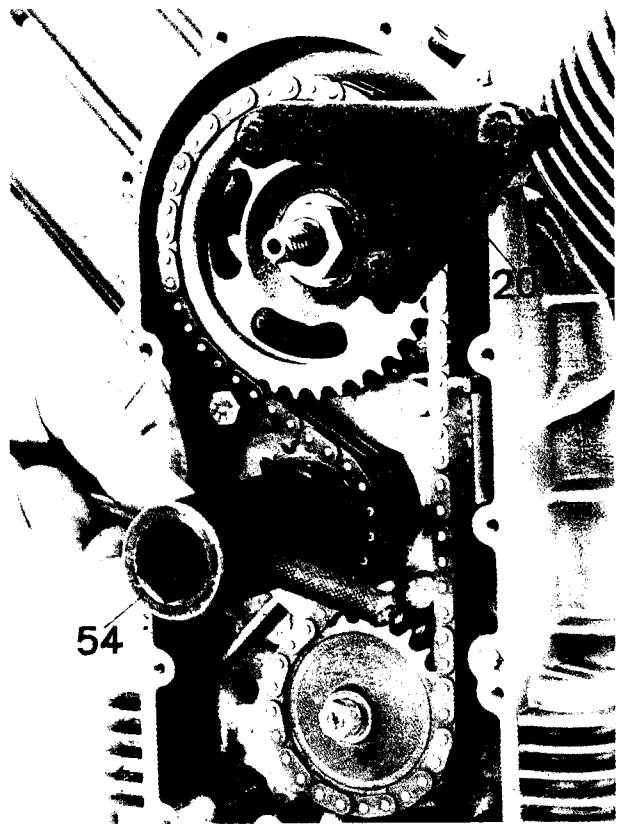

80/2

81

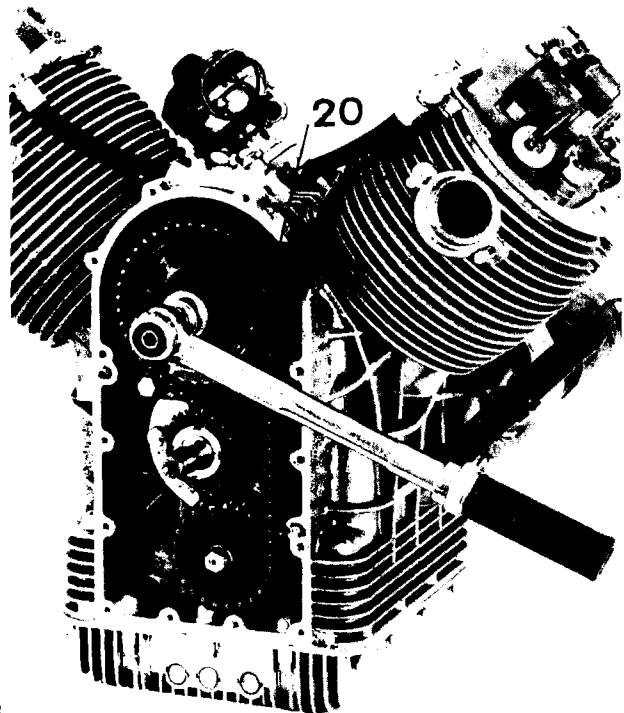

80/3

59

14 ENGINE LUBRICATION

The oil sump («C» in fig. 82/3) acts as an oil tank and contains 3 liters of oil (abt. $\frac{3}{4}$ US gls.).

Lubrication is by pressure. Delivery by spur gear pump, recovery by gravity. The pump is gear driven directly by the camshaft and includes: a wire gauze filter, a cartridge filter, an oil pressure relief valve, and the drain plug.

14.1. OIL DELIVER PUMP

It is of spur gear type. The gear driving shaft is carried by two roller bearings housed in the oil pump body.

Inspections and controls (see fig. 82-82/1-82/2)

In case of improper operation of the oil pump, check accurately the following:

- Depth of gears. Should be 13.973-14.000 mm (.551-.551").
- Gear housing in pump body. Should be 14.032-14.075 mm (.5524-.5541").

If not within the above sizes, the parts should be replaced.

It is also important to check that the O/D of the gears does not exceed 26.250-26.290 mm (1.0333-1.0377") and that of the pump housings in the body is no more than 26.340-26.390 mm (1.0369-1.0389").

Also the O/D of the roller bearing race (Durkopp Naf 10 × 22 × 20) should be within 21.989-22.002 mm (.8657-.8662") and housing O/D in the pump body should be within 21.972-21.993 mm (.8649-.8659").

Check also the I/D of the roller bearing race (Durkopp Naf 10 × 22 × 20) which should be 9.990-10.002 mm (.3932-.3937").

If not within the above sizes, the parts should be replaced.

Back lashes

- Between pump gear shaft (9.985-10.000 mm = .3930-.3937"), and the housing in the pump body (10.013-10.035 mm = .3943-.3950") should be 0.013-0.050 mm (.00051-.0019").
- Between outer roller bearing race (21.989-22.002 mm = .8657-.8662") and housing in pump body (21.972-21.989 mm = .8649-.8656") should be from a clearance of 0.004 mm (.00015") to a negative allowance of 0.030 mm (.0011").
- Between I/D of roller inner race (9.990-10.002 mm = .3932-.3937") and pump shaft (9.085-10.000 mm = .3930-.3937") should be from a clearance of 0.017 mm (.00066") to an interference of 0.010 mm (.00039").
- Between gears on pump shaft (26.250-26.290 mm = 1.0333-1.0350") and the pump body housings (26.340-26.390 mm = 1.0369-1.0389") should be 0.050-0.140 mm = .0019-.0055").

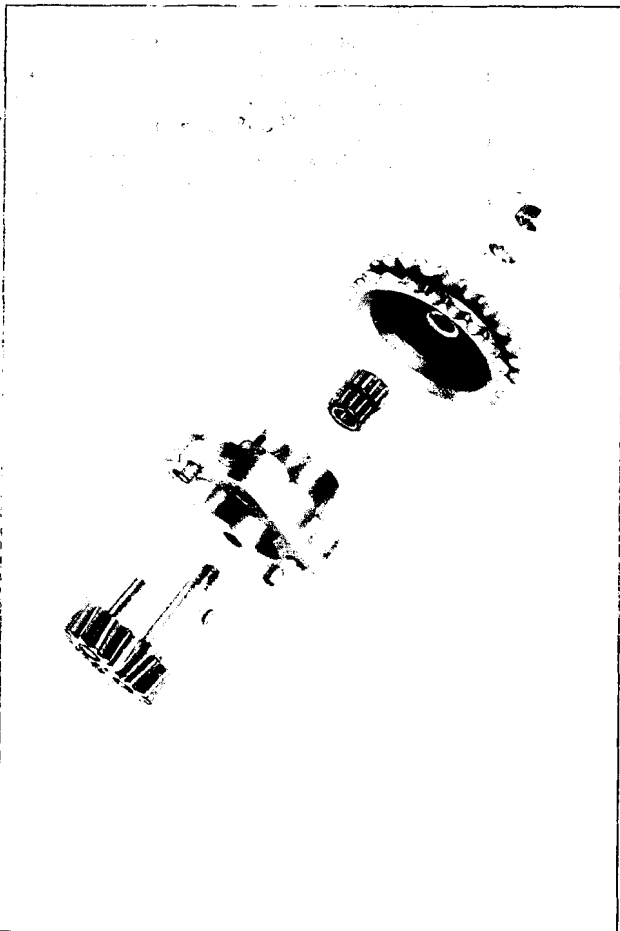
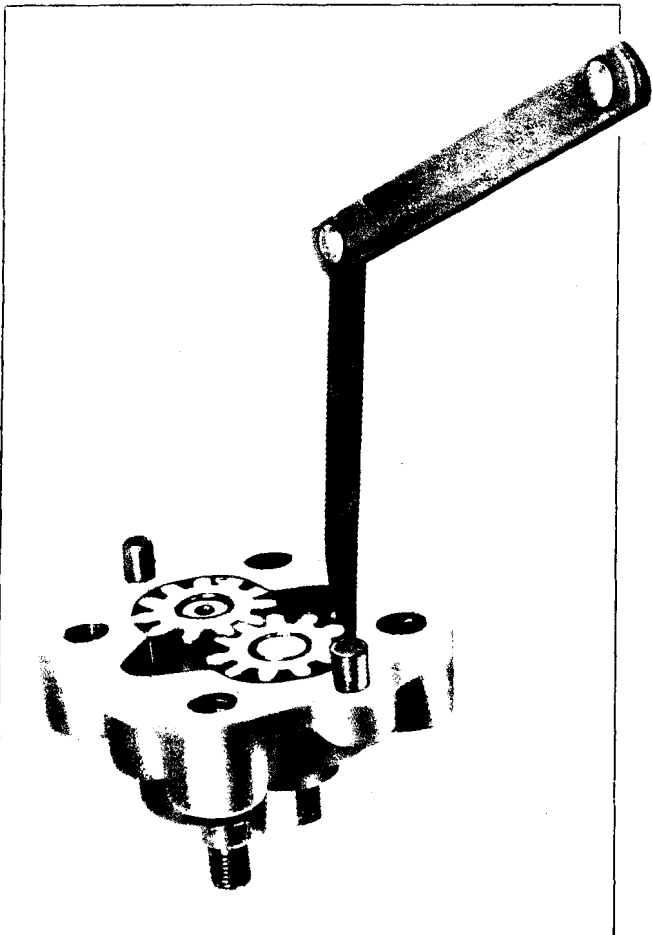

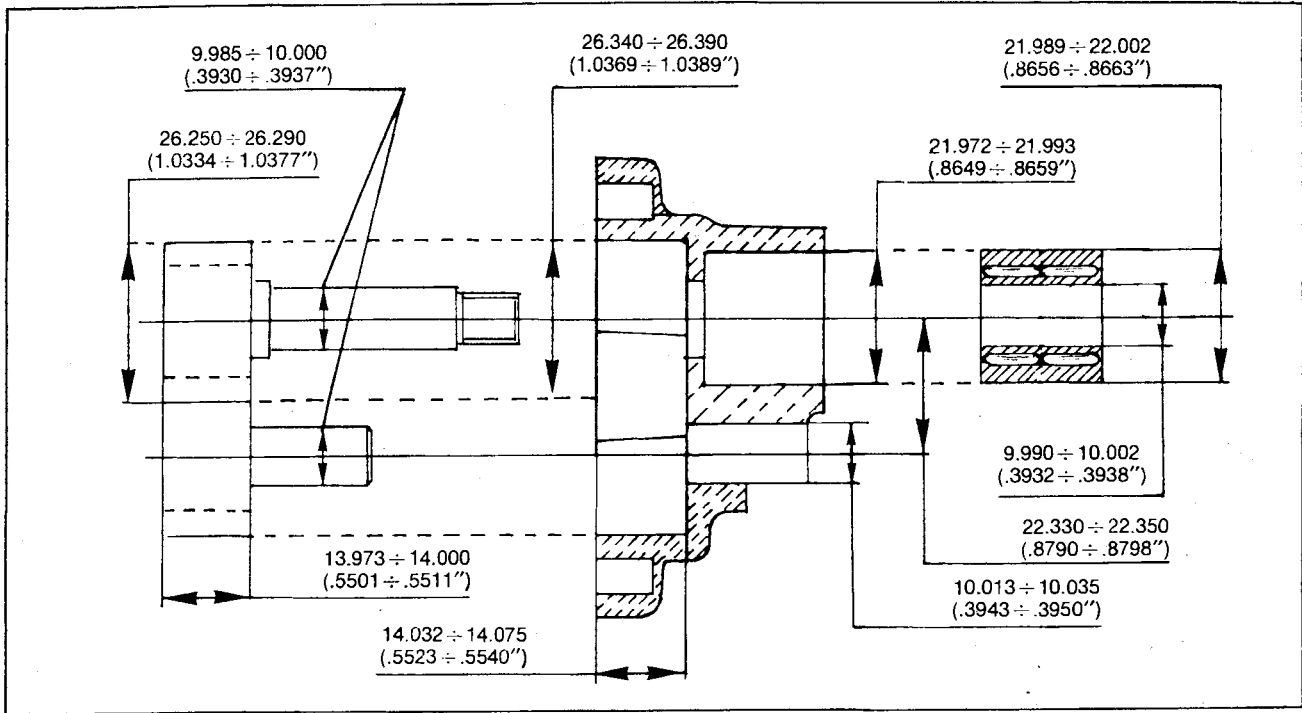

82/2

14.2 OIL SUMP (fig. 82/3)

The following are fitted on oil sump «C»:

- «A» removable filter cartridge.
- «B» magnetic drain plug.
- «D» wire gauze filter.
- «E» oil pressure relief valve.

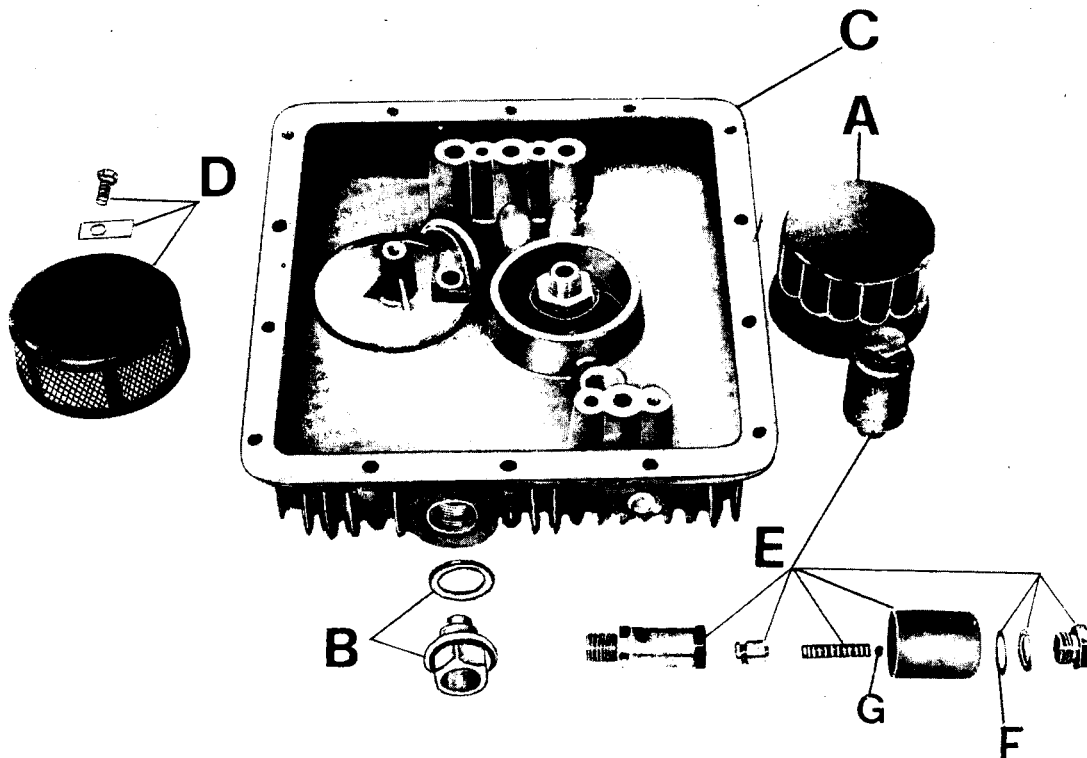

82/3

14.3 REPLACING THE OIL FILTER CARTRIDGE (fig. 82/3)

Should be changed every 15.000 km (9000 miles or 5 oil changes) proceeding as follows:

- Undo the drain plug with aluminium washer «B» and remove the filler cap. Let all the old oil drain from the sump.
- Undo the sump securing screws and remove the complete sump unit (C).
- Screw out cartridge «A», wire gauze filter «D» and the oil pressure relief valve «E».
- Blow compressed air on all these items after having washed them in petrol.
- Using a pressure gauge, check if oil relief valve «E» starts operating at the normal specified pressure i.e. 3.8-4.2 kg/sqcm (54-60 lbs). If not see section «Oil pressure relief valve».

Then refit all removed parts and the pump itself (change its gasket), tightening all securing screws. Introduce about 3 liters (abt. 3 qts.) of AGIP Sint 2000 oil, SAE 10 W 50. Refit the plug with dipstick on the crankcase, after ensuring the oil level is up to the top notch.

14.4 WIRE GAUZE FILTER (fig. 82/3)

Wire gauze filter «D» is fitted in the oil sump (C) and is retained by a small bolt with lockplate. When changing the cartridge, it is well to clean also this filter and to dry it off with compressed air.

14.5 OIL PRESSURE RELIEF VALVE (fig. 82/3)

This valve (E) is screwed in the oil sump and is calibrated at the factory for a pressure of 3.8-4.2 kg/sqcm (54-60 lbs/sq. in). In case of a higher pressure this valve opens bringing it down to the specified limits. To dismantle the valve see «E» in fig. 82/3 and fig. 82/4.

Checking this valve («E» in fig. 82/3)

To check if this valve opens at the specified pressure, it is necessary to set it up on a special tool (part N. 17 94 97 60 23 in fig. 82/5) fitting a manometer and watching by blowing compressed air through it if the valve opens at the specified pressure. If for any reason the valve opens before normal pressure is reached, it is necessary to remove it and to fit one or more shim «G» on top of the spring. If the pressure is higher than specified, remove the valve and take one or more shims «F» from the spring top.

14.6 OIL PRESSURE SOLENOID

It is fitted in the crankcase and it is connected by cable to the warning light on the panel. Its purpose is to warn about insufficient oil pressure in the circuit.

82/4

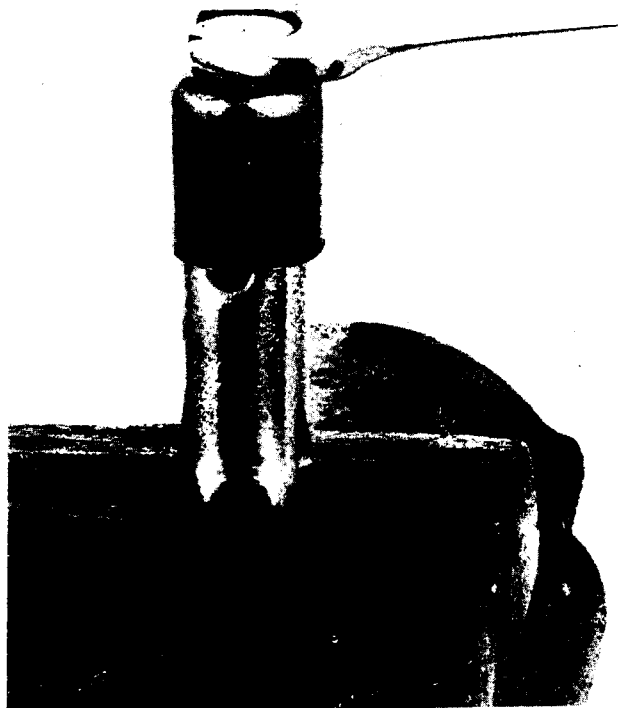

82/5

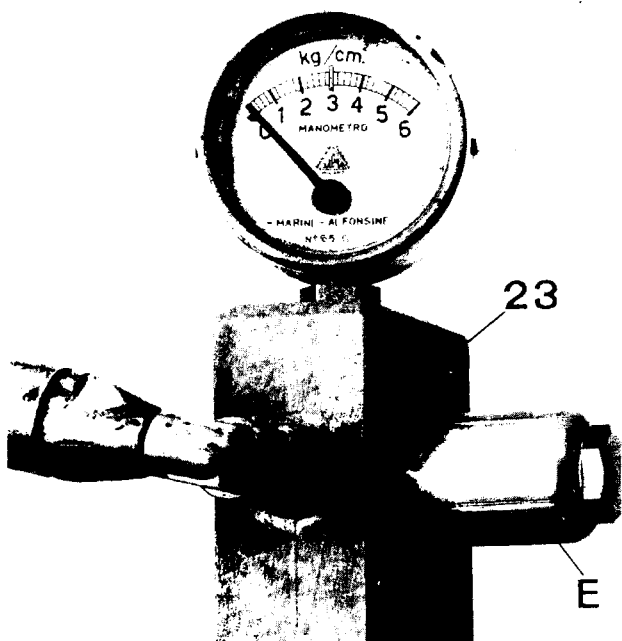

When this indicator lights up during normal riding, this means the oil pressure in the circuit has dropped below the specified limit and in such a case the engine should be stopped immediately and the oil circuit checked over in order to find the cause for the pressure drop.

Checking the oil pressure solenoid

To determine the efficiency of this solenoid, set it up on tool part N. 17 94 97 60 (23, fig. 82/6) with a pressure gauge. Connect positive cable (+) of the TESTER to the solenoid and ground negative cable (-).

Then blow compressed air through the tool opening, ensuring that the TESTER needle moves when the pressure reaches a value of 0,15-0,35 kg/sqcm

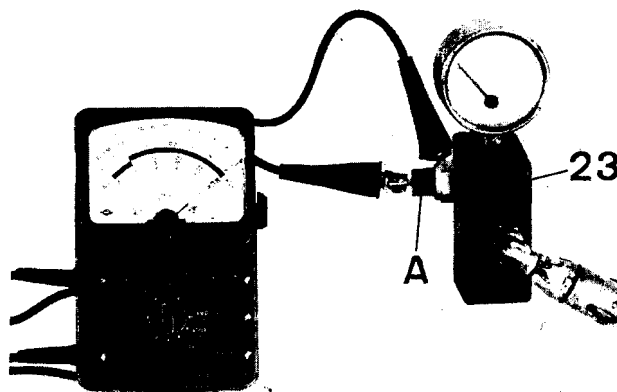

82/6

14.7 CHECKING THE OIL PRESSURE WITH THE ENGINE ON THE BYKE

Proceed as follows:

- Disconnect the L/H crankcase cable from the solenoid.
- Screw the solenoid out of its housing in the crankcase.
- In this housing, screw in the terminal of the gauge cable.
- Start the engine and run it up to its normal operating temperature, checking if the pressure is as specified.

To make sure the pressure is correct, it is well to secure the gauge to the R/H bumper and to ride the byke for about 10 km (6 miles), observing if the instrument dial is always at correct pressure.

Finally, remove the dial from the crankcase hole, refit the solenoid and connect its cable.

15 CARBURATION

15.1 CARBURETTORS (fig. 83)

These models fit two Dell'Orto carburetors type VHB 30 CD (right) and VHB 30 CS (left).

Controls

- Throttle twist grip and the R/H side of the handlebar.
- Easy start lever for cold starts, controlling both carburetors.
- «B» Cold start position.
- «C» Normal riding position.

NB Be always sure that with starter lever in riding position «C» there is a clearance of about 3 mm (.118") between cable terminals and cable tensioners of both carburetors «H».

Carburettor setting

Choke	30 mm dia.
Throttle valve	40
Atomizer	265
Main jet	125
Pilot jet	50
Starter jet	80
Taper needle	V 9-2nd notch from top
Floater	10 gr
Idling screw:	open 1½ turns.

15.2 FLOAT LEVELLING (fig. 84)

This operation is carried out as follows:

- Remove the lower float chamber.
- Tilt the carburettor over (w/o chamber) so that the float needle closes the fuel flow.
- Place template 14 92 69 00 (19 in fig. 35) on the carburettor face (where the chamber is screwed in) and check that both floats are just flush with the inside of the template, but do not force against it. If not, operate on the float pins till both are perfectly lined up (bear in mind there are extremely delicate).

For carburetors with 10 grams floats, the distance from the top carburettor face to the float crown should be 23,5 mm (.924").

15.3 ADJUSTING THE CARBURATION AND IDLING SPEED (fig. 83)

Proceed as follows:

- 1 With the throttle grip fully closed, ensure there is 1-1.5 mm (.039-.059") end play between the cable terminals and cable tensioners «F» of both carburetors.
- 2 Run up the engine to its normal operating temperature.
- 3 Screw idling screws «E» fully home and then undo them 1½ turns.

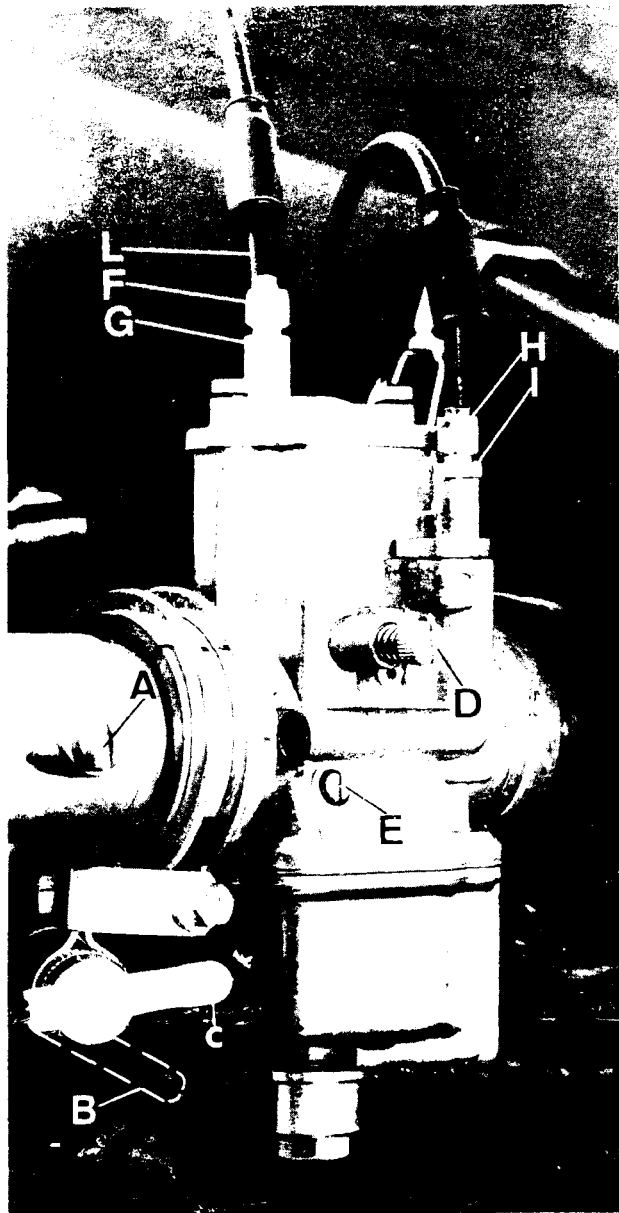

83

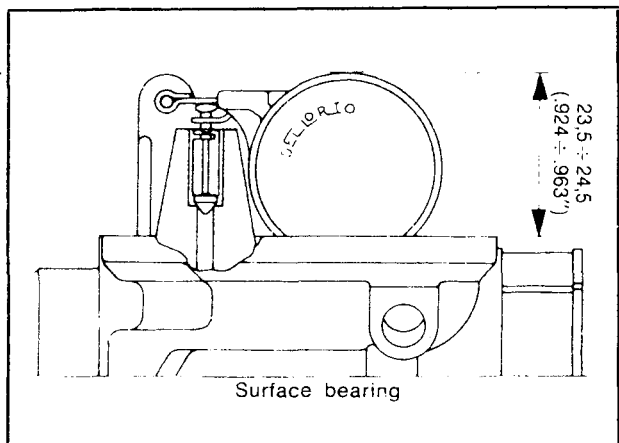

84

4 Using both hands at the same time, check if the pressure at both exhaust pipe ends is uniform. In case it is different, operate on screw «D» of one carburettor till the pressures are equal (since the idling speed has to be kept at about 900-1000 rpm, it might be necessary to screw on the carburettor screw of the cylinder giving a higher pressure or screw in the carburettor screw of the cylinder giving a lower pressure.

5 Operating on screws «E», adjust each cylinder to point where carburation is best (this is perceived by a slight increase of the engine revs) and then re-set idling speed as described at 4.

6 Disconnect one plug lead at the time and check that in each instance that the engine stops after firing the same number of strokes (5 or 6). If not, undo screw «D» of the carburettor for the cylinder firing too much or screw in the carburettor screw of the cylinder firing less.

7 Adjust idling speed to about 900-1000 rpm., screwing in or out both screws «D» by the same amount.

8 Check if the throttle slides open simultaneously, as follows:

- With the assistance of a second person, slowly and gradually turn the twist grip and with both hands check if the pressure increase at each exhaust pipe end is synchronous.

- If not, adjust carburation of the cylinder in advance (as compared to the other) by gradually screwing in cable adjuster «F» (after loosening counter-nut «G») until the pressure is the same for both exhaust pipes.

15.4 CHECKING CARBURATION WITH A VACUUMETER (fig. 85)

1 Check that both starter cables have about 3 mm (.118") idle run at tensioners «I» entry (fig. 83). This play is adjusted by loosening nut «J» and screwing in or out screws «H» (see fig. 83).

2 Check that at their fitting end both tensioners «F» cable screws have about 1-1.5 mm (.039-.059") end play.

To adjust this play, undo locknut «G» and screw in or out tensioner «F» (fig. 83). Then tighten again locknut «G».

3 Adjust screw «E» (fig. 83) screwing it in fully and then undoing it 1½ turns (for both carburettors). Undoing screw «E» increases the fuel flow and vice versa decreases it.

4 Undo both rubber caps of intake pipes «A» and in their place fit pipes «B» of vacuumeter «C».

5 To adjust idling speed (hot engine) proceed as follows:

- Start the engine with the throttle control at minimum opening and obtain about 900-1000 rpm. operating on throttle adjusting screw «D» (fig. 83). Ensure now that both vacuumeter columns «D» (fig. 85) are at same height. If not operate on screw «D» (fig. 83) till they are at same level.

6 Adjust position of idling screws «A» (fig. 83) to obtain the highest possible idling speed.

Re-check now the position of vacuumeter columns «D» (fig. 85) and if necessary repeat operation n. 5.

7 Synchronize the carburettors, after adjusting idling speed. Do this operation as follows:

- Start the engine and accelerate gradually, observing mercury columns «D» on the vacuumeter dial are lined up to each other (fig. 85). If not, loosen counter-nut «G» (fig. 83) and operate on tensioners «F» of gas control cables «L» till both columns are at same height.

After this, screw out the tubings from the intake housings «B» (fig. 85) and refit the securing screws with their washers.

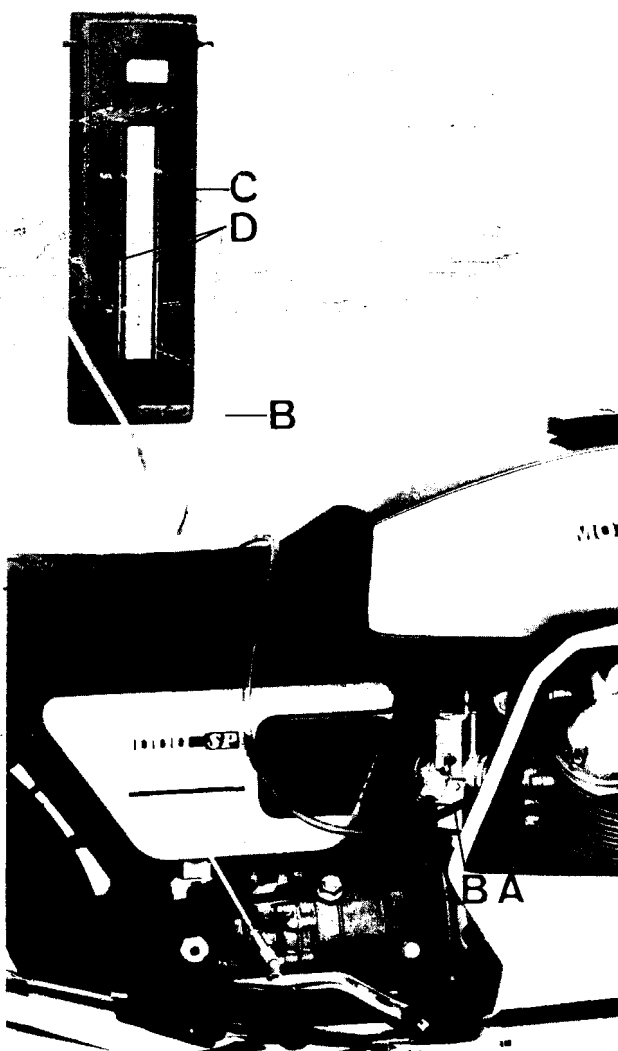

15.5 CARBURETTOR COMPONENTS (fig. 86)

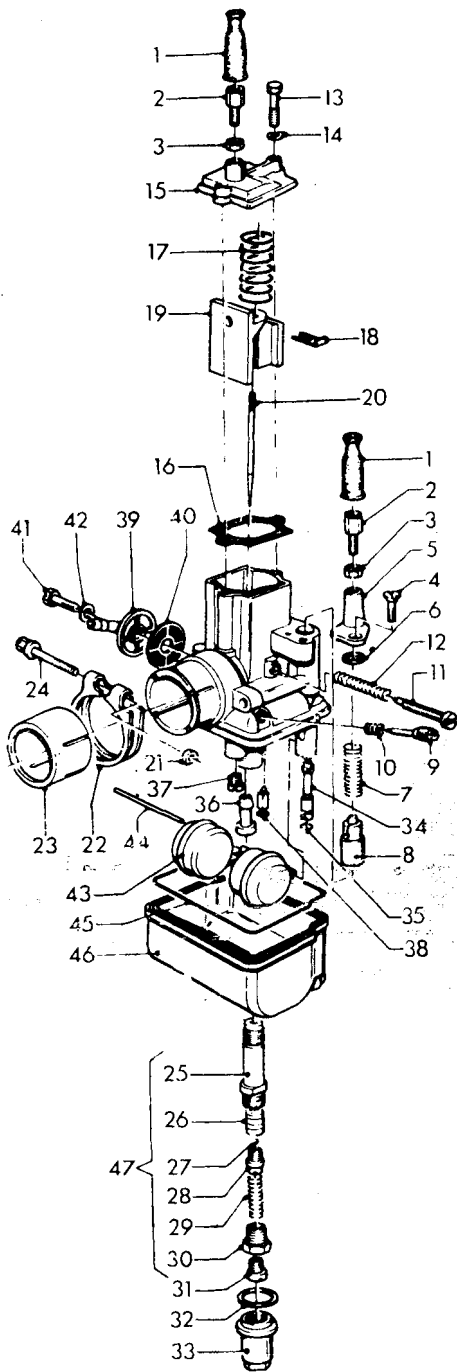

- 1 Rubber caps, cable adjusters.
- 2 Throttle control and starter cable adjusters.
- 3 Throttle and starter cable nuts.
- 4 Starter cover securing screw.
- 5 Starter cover.
- 6 Gasket, starter cover.
- 7 Starter valve spring.
- 8 Starter valve.
- 9 Idling screw.
- 10 Idling screw spring.
- 11 Throttle valve adjusting screw.
- 12 Throttle valve adjusting screw spring.
- 13 Throttle valve cover screw.
- 14 Throttle valve cover screw washers.
- 15 Throttle valve cover.
- 16 Throttle valve cover gasket.
- 17 Throttle valve spring.
- 18 Taper needle clip.
- 19 Throttle valve.
- 20 Taper needle, «V» type.
- 21 Lockring clip.
- 22 Clip.
- 23 Insulating rubber.
- 24 Clip locking screw.
- 25 Pump body.
- 26 Pump plunger.
- 27 Ball valve.
- 28 Valve seat.
- 29 Valve spring.
- 30 Main jet holder.
- 31 Main jet.
- 32 Float chamber plug gasket.
- 33 Float chamber plug.
- 34 Starter jet.
- 35 Starter jet washer.
- 36 Atomizer.
- 37 Slow running jet.
- 38 Fuel cutout needle.
- 39 Banjo union.
- 40 Fuel filter.
- 41 Banjo union securing bolt.
- 42 Banjo union securing bolt washer.
- 43 Float.
- 44 Float pin.
- 45 Float chamber gasket.
- 46 Float chamber.
- 47 Fuel pump.
- 48 Carburettor body.

15.6 REPLACING THE AIR FILTER CARTRIDGE ON ASSEMBLED ENGINE (fig. 87)

Every 10.000 km or so (6000 miles) replace air filter cartridge «C». This is located in a separate container under the fuel tank together with the oil breather unit.

To remove this cartridge from the breather housing «A», proceed as follows:

- Raise the saddle and hold it up with its rod.
- Take off the tool box after removing its stirrup.
- Unhook the rear tank retaining strap and remove the tank (after closing the taps and disconnecting the fuel lines).
- Disconnect battery cables, unhook battery straps, and lift battery up from its bracket.
- Unhook spring retainers «E» and withdraw rubber sleeve «F» from the air intake tubes and the breather assembly.
- Undo nut «B» securing breather «G» (after disconnecting it from pipe unions «H» complete with pipings and tubes «I») and from the breather remove filter «C» with bottom plate «D», paying attention to the datum mark and how it is assembled. After replacing cartridge «C» with an original piece, re-assemble reversing the dismantling sequence.

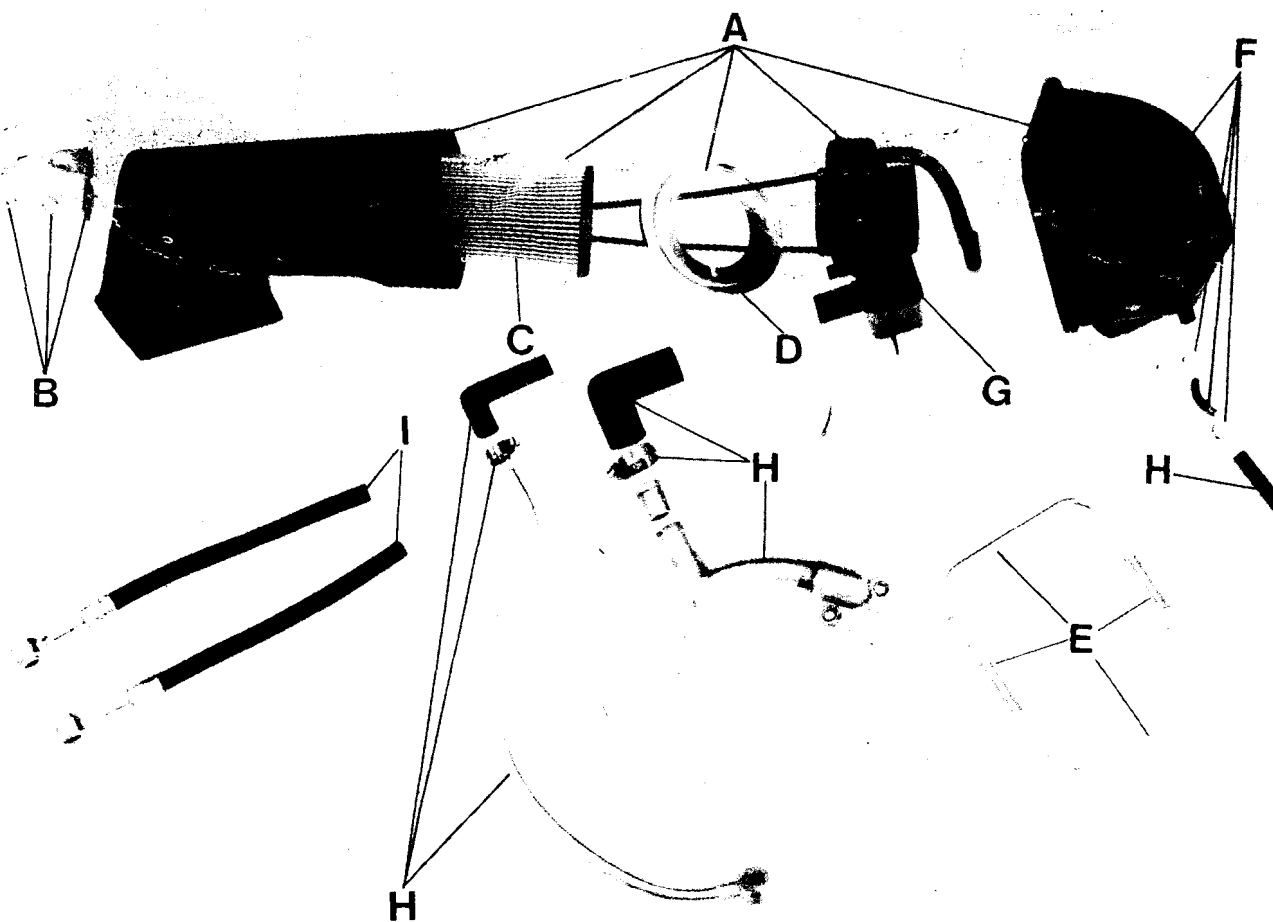

16 CLUTCH

Twin driven plate, dry type (fig. 88).

16.1 REMOVING THE CLUTCH ASSEMBLY

After separating the engine from the gearbox, fit tool 12 91 18 01 (21 in fig. 37) on the crankcase studs and by the aid of a wrench undo the 8 bolts securing the ring gear to the flywheel and take off:

- driven plate;
- intermediate plate;
- driven plate;
- pressure cap;
- pressure plate;
- the 8 springs from their housings in the flywheel.

16.2 INSPECTIONS

Clutch spring (fig. 89)

Ensure all springs are still efficient and have not lost their load. Spring compressed to 20 mm (.7874") should give a load of 21-21.5 kg (46-47 lbs). Spring compressed to 17 mm (.787") should give a load of 28.7-29.7 kg (63-65 lbs).

Pressure plate

Check wear of the inner surface contacting the pressure cap, also that the surface contacting the driven plates are dead smooth or else there will be noisy clutch operation. Check also if the engaging teeth inside the flywheel are in good condition.

Driven plates

Width of each new plate is 8 mm (.3149"). Replace it any time it is worn down to less than 7.5 mm (.2953"). Check also condition of teeth.



Intermediate plate

Ensure the surface contacting the driven plates is quite flat and smooth, also the condition of the teeth inside the flywheel.

Replace the plate, if necessary.

Starting ring gear

Check flatness and smoothness of the surface contacting the driven plate. The teeth engaged by the starter motor pinion should also be checked for scoring or nicks.

Control cable

If the inner wire is broken or in any way damaged, replace the cable.

Adjuster screw on clutch operating lever

Check condition of the lever dowel and screw, especially the screw section which operates on the outer clutch body. Replace it if too much flattened.

Operating lever return spring on gear box

Ensure it has not lost its load and has not deformed.

Throwout bearing

Ensure the balls are in good state. If not, replace the bearing.

Outer body

Check surface contacted by the dowel. If worn or deeply scored, replace the body.

Inner body

Inspect the surface contacted by the bearing balls. If worn or scored, replace the body.

Taper bushing in clutch shaft

Check if still in good state and not hardened or crumbled. It is possible that squeaks or oil leakages in the clutch plate may depend from these bushes.

Pressure plate rod

If worn, deformed, or become shorter, replace it.

Pressure plate rod cap

Ensure that the part working on the pressure plate is not worn or else replace the cap.

Outer body seal

If crumbled or has lost its elasticity, replace the seal.

16.3 ASSEMBLING THE CLUTCH ON THE FLYWHEEL

The flywheel is stamped externally with an arrow which besides indicating TDC is also a reference mark for an easier assembly of the pressure plate.

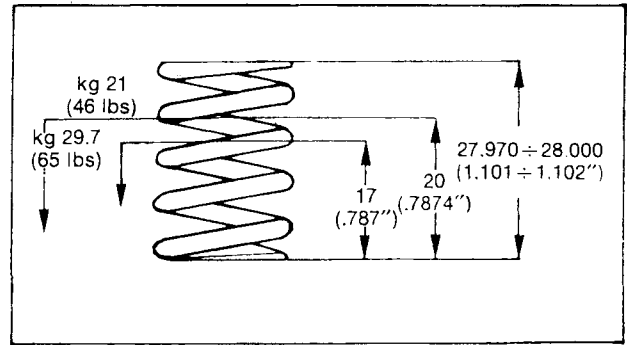

89

The correct sequence for assembling the clutch unit is:

- Insert the 8 springs in their housings on the flywheel.
- Fit the pressure plate on the inner flywheel teeth in correspondence with the TDC arrow.
- Set up tool part N. 12 90 65 00 (28 in fig. 37) on the crankshaft, screwing it down just sufficiently to allow the correct positioning of the internal driven plate and ring gear.
- Screw down tightly the ring gear securing bolts. To prevent the flywheel from turning when tightening these bolts, use tool N. 12 91 18 01 (21 in fig. 37) set up on the crankcase studs and a wrench.

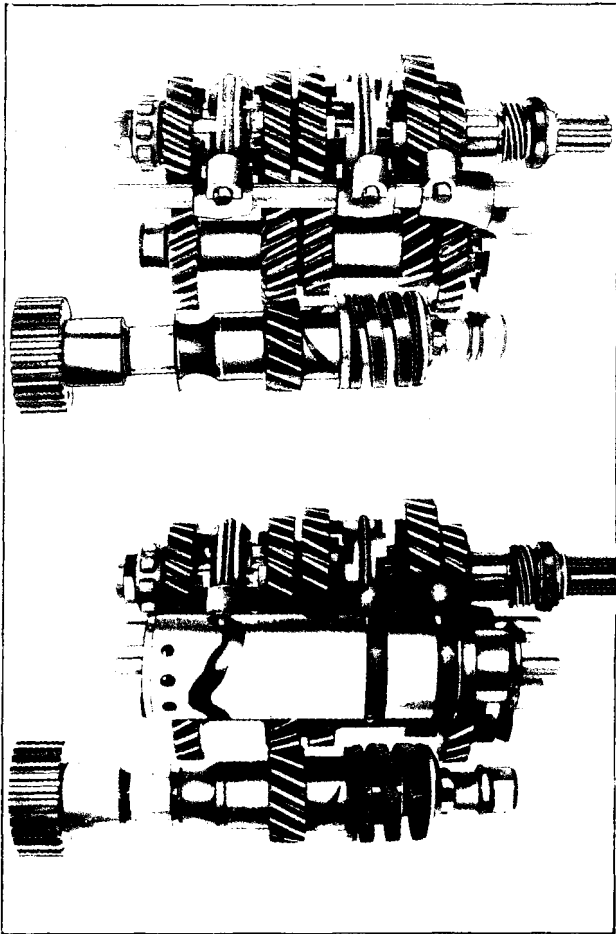

90

17 GEAR BOX

(fig. 90)

This operates independently from the engine and incorporates constant mesh gears with frontal engagement

Engine-gearbox ratio 1.235 to 1 (17.21)

Internal gear ratios

Low gear	1 to 2 (14.28)
2nd gear	1 to 1.388 (18.25)
3rd gear	1 to 1.047 (21.22)
4th gear	1 to 0.869 (23.20)
high gear	1 to 0.750 (24.18)

17.1 STRIPPING THE GEARBOX

First of all drain all its oil and then proceed as follows:

- set the gearbox up on stand N. 14.92.96.00 (52 fig. 91) and clamp it in a vice;
- undo the selector operating lever screw and remove lever;
- remove speedo drive;
- undo layshaft securing nut by the aid of tool N. 12.90.71.00 (34, fig. 91) and tool 14.90.54.00 (31, fig. 91);
- remove the speedo drive gear. Be careful not to lose the ball which acts as a key;
- remove clutch operating lever from gear box, taking out the split pins and retaining spindle;
- remove lever return spring, outer body, throwout bearing, inner clutch body, and the clutch operating rod.

Removal of gearbox cover

To take this off, it is necessary for the gearbox to be in the neutral position. Then undo the Allen screws and by the aid of a hide mallet tap the cover to allow its separation. When removing the cover from the layshaft make sure not to mislay the speedo gear drive shim and the O'ring.

Removal of gearbox components

Selector fork, sliding sleeve, and high speed gear.

These components are removed as follows:

- withdraw the selector rod;
- high speed selector fork
- high speed sliding sleeve;
- high speed gear from layshaft;
- high speed gear from main shaft complete with roller cage and bush;
- this done, use a pointed rod to force the stop dowel down completely in its housing on the shaft. Then turn the bushing to the right or left and take out

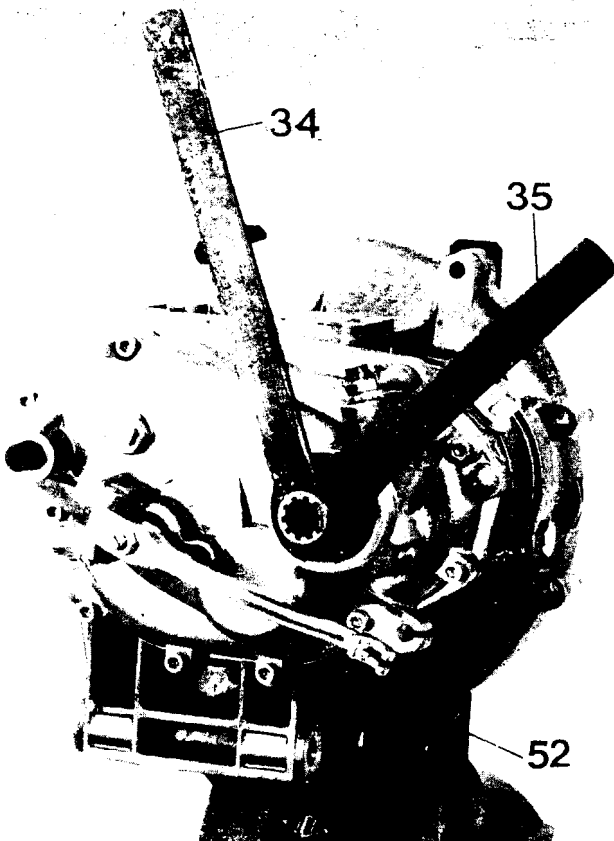

91

the gear complete with roller cage, taking care not to mislay the small spring and the stop dowel.

Selector drum

Undo the oil breather nut from the box and remove:

- Spring (the oil breather nut has also the function of retaining the pawl which acts as a stop on the selector drum). The pawl will remain in its housing in the gearbox and can be removed only after the complete gearbox has been stripped).
- Undo the securing screws and take out the neutral indicator solenoid from its housing in the gearbox.
- Slip off the gear selector drum complete with rod, paying particular attention to the position of the shims.
- Lift out the rod from the drum.

Shafts complete with gears and sliding muff forks of layshaft

From the gearbox take out the complete layshaft («1» fig. 92) and from this remove:

- seal ring at the gearbox cover end;
- low speed gear, roller cage, and bushing;
- sliding sleeve for first and 2nd speed;
- nut at the 4th speed gear side;
- roller bearing;
- shims:

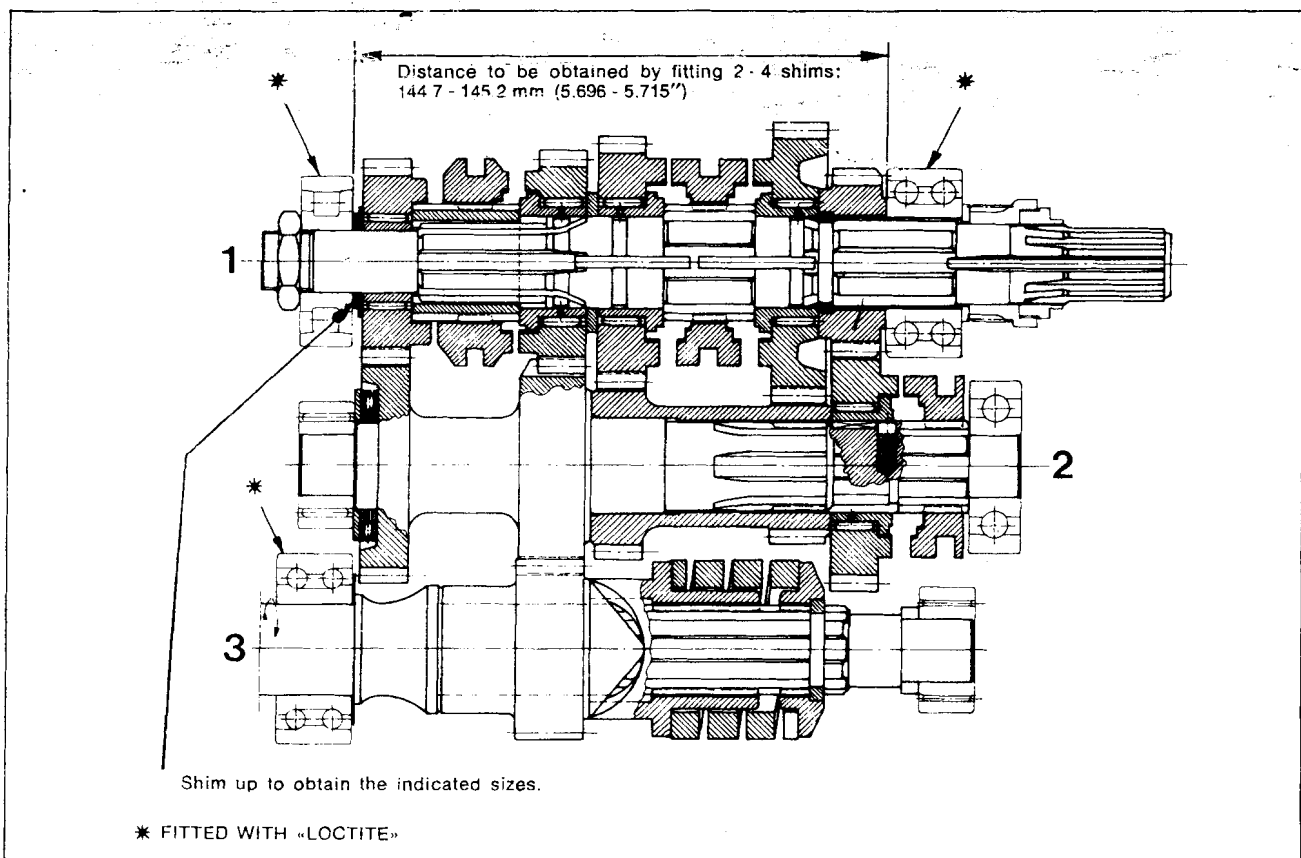

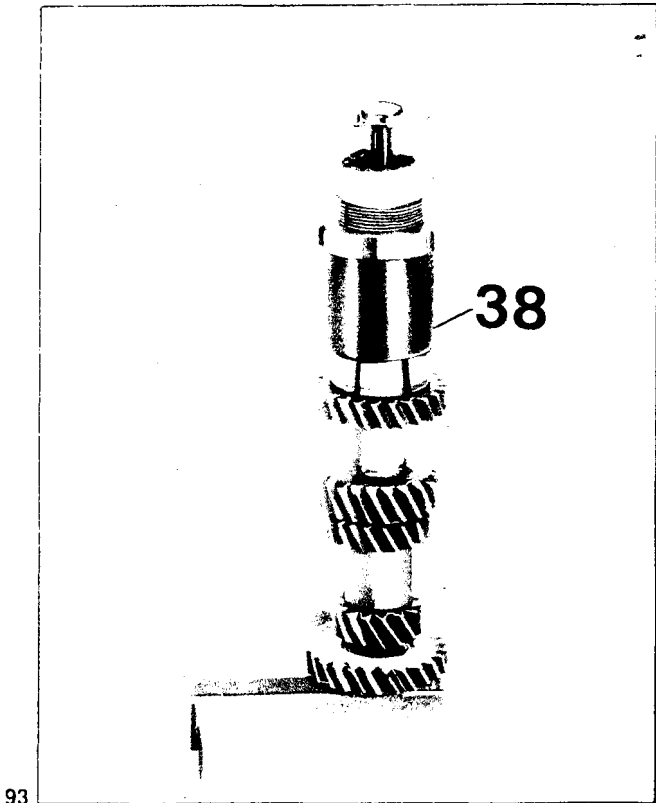

93

- 4th speed gear with roller cage and bushing;
- sliding sleeve for 3rd and 4th speed;
- fixed sleeve on the shaft;
- 3rd speed gear with roller cage and bushing;
- shim;
- 2nd speed gear with roller cage and bushing.

Main shaft («2», fig. 92)

Slip out the shaft from the gear box. All gears on this shaft are fixed except the high speed gear which is floating in its roller bearing; and the high speed sliding muff, also the throwout bearing and shim. The main shaft inner bearing race is removed using tool 14 92 85 00 (38, fig. 93).

Clutch shaft («3» in fig. 92)

Using tool 14 91 28 00 (36 in fig. 94) and hook wrench 14 91 26 00 (37, fig. 94) and after flattening the ears of the safety washer, remove the fixed clutch body retaining ring from the clutch side and then the fixed body itself.

When dismantling the fixed clutch body observe the position of the seal between body and bearing.

Slide off the clutch shaft from the bearing and, if necessary, use a hide mallet to lightly tap it, making sure not to mislay the oil scoop between shaft and bearing and the washer in the shaft spline.

Removing the clutch shaft components

Use puller 14 92 85 00 (38 in fig. 95) to remove the inner race of the roller bearing and the spacing nut. Then set up the complete shaft in a vice and using puller 12 90 59 00 (29 in fig. 96) compress the spring to the point where the clutch drive plate retainers can be taken out.

Then remove:

- clutch plate;
- spring;
- sliding muff;
- Intermediate gear;

Removing the bearings from the gearbox

Proceed as follows:

- place the complete gearbox with bearings in an oven and heat up to 150-160° C (300-350° F);
- using puller 14 91 31 00 (39 in fig. 97) remove the main shaft bearing;
- take out the outer race from the layshaft bearing using tool 17 94 50 60 (40 in fig. 98);
- remove the clutch shaft seal;
- undo the safety plate retaining screws;
- remove safety plate;
- remove the clutch shaft bearing using tool 17 94 92 60 (41 in fig. 99).

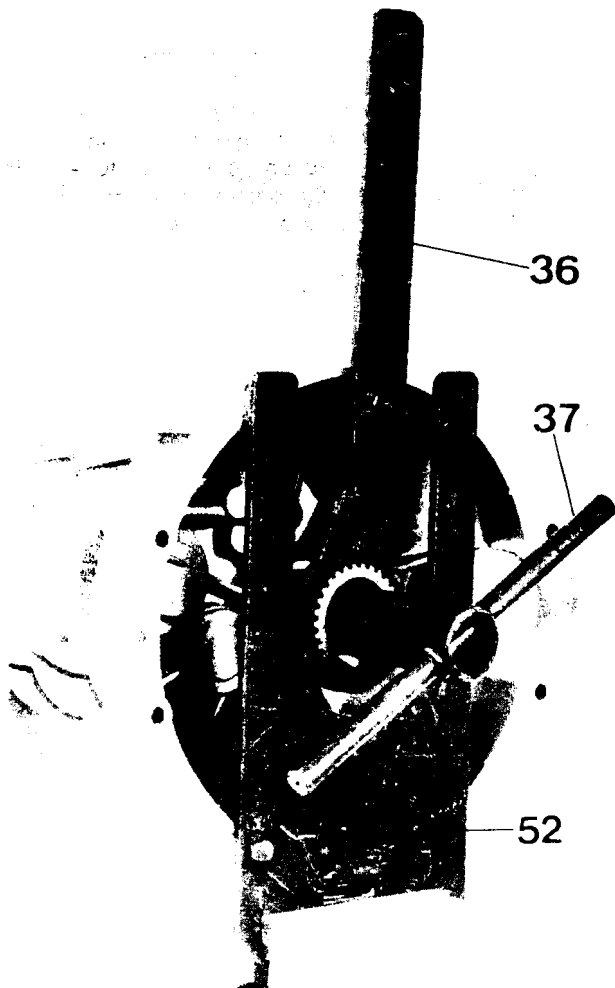

94

Removing the gearbox cover components and the selector assembly

Using a hide mallet, tap off the selector unit from the gearbox cover. Remove the return spring from the selector pin.

After undoing the locknut, from the cover remove the selector adjusting screw and the O-ring from the selector spindle.

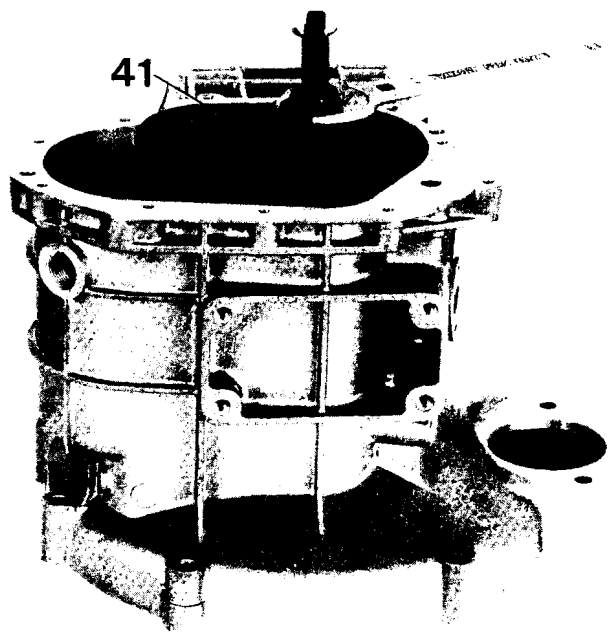
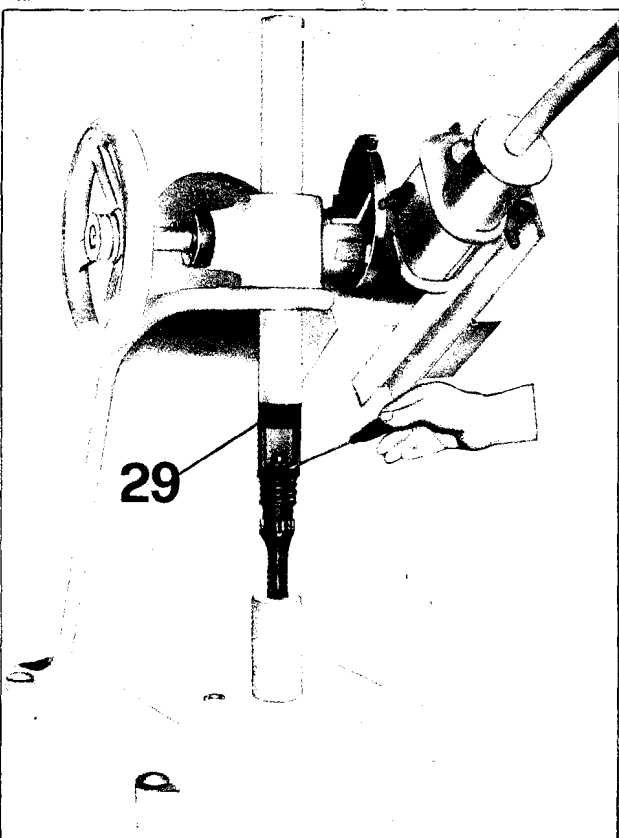
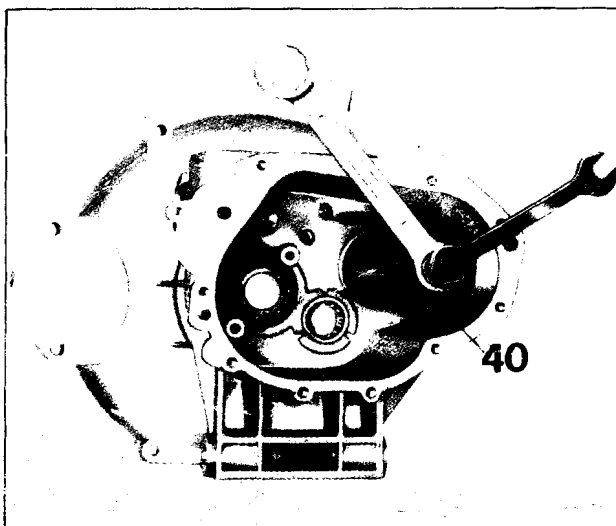
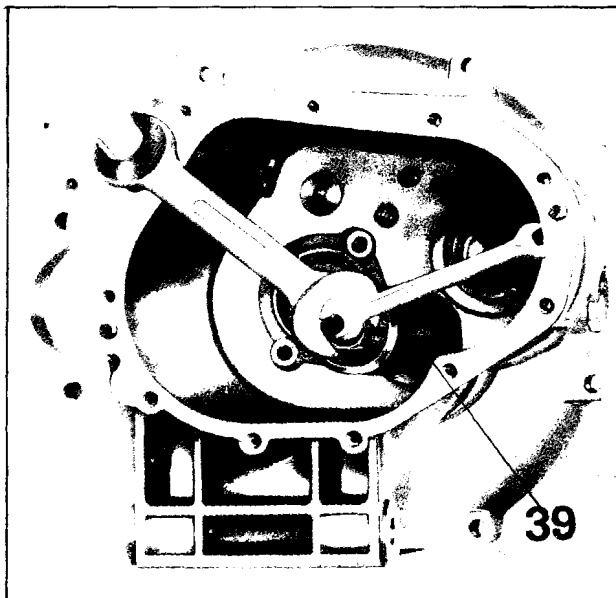
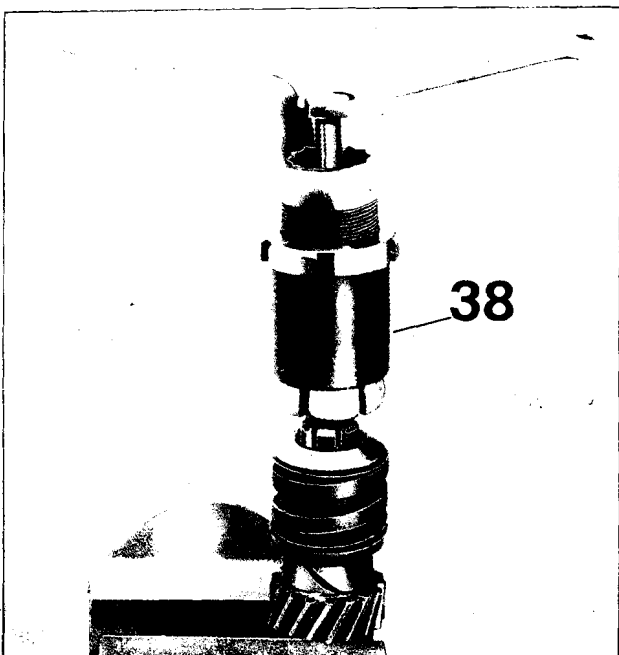

Removing the bearings from the gearbox cover

Proceed as follows:

- Put the cover in an oven and heat up to 150-160° C (300-350° F).
- Using puller 14 90 70 00 (42 in fig. 100) remove the main shaft ball bearing
- Remove the clutch shaft roller bearing using puller 14 91 31 00 (39 in fig. 101)
- Remove the layshaft seal
- Undo the lockplate securing screws
- Remove lockplate.
- Remove the layshaft bearing by the aid of puller 17 94 92 60 (41 in fig. 102)

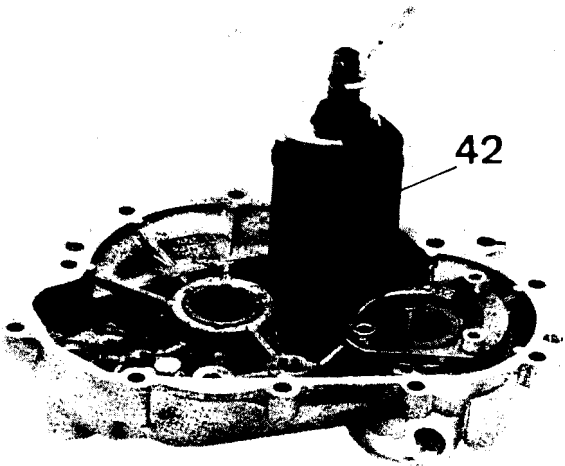

100

17.2 CHECKING AND OVERHAULING THE GEARBOX COMPONENTS

Gearbox and cover

Check for any cracks or nicks, smoothness of the union faces, and if the bosses thread is stripped

Rubber seals

Whenever these are removed from their housings, it is best to change them to assure perfect tightness

Ball and roller bearings

Check their condition and make sure they are not too slack in their housings. All rolling surfaces, balls and/or rollers should show up very bright and smooth.

Main shaft

Check wear of the gear teeth and replace the shaft if unduly worn.

High speed gear on main shaft

Check for nicks or excessive wear and if necessary replace the gear.

High speed gear bushing

Ensure the surface contacted by the rollers is quite smooth, also the surface of the inner grooves. If scored or nicked, replace the bushing

High speed bushing retainer

Replace it if scored or not perfectly smooth.

Thrust spring for high speed gear bush retainer

If deformed or has lost its efficiency, replace it. When compressed to 8 mm (.031"), the spring should have a load of 1.40 kg \pm 5% (3.1 lbs).

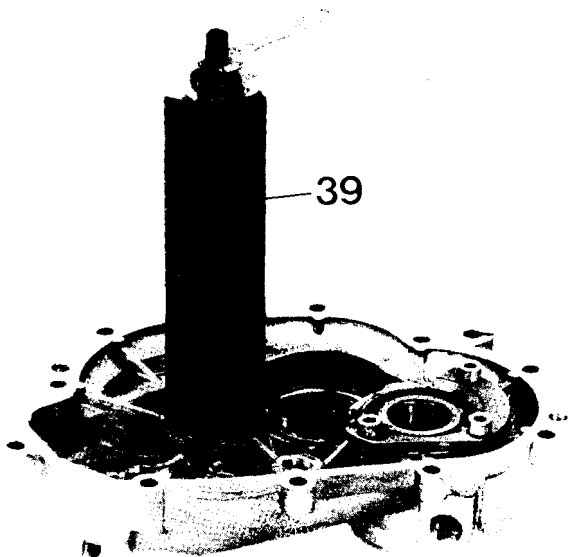

101

Layshaft

Should show up very smooth at its contact surfaces. If scored or the threaded portions are stripped, replace the shaft.

Sliding muff

Check smoothness of all sliding surfaces and ensure that the front engaging dogs are not damaged.

Gears on layshaft

Check teeth wear, also wear of the engaging dogs. The teeth contact surface should be quite smooth and free from scoring or nicks. Replace the gears, as necessary.

Roller bearing securing nut on layshaft

Ensure its thread is still in good condition. If stripped or damaged, replace the nut.

Bushings for roller cages - 1st, 2nd, 3rd, and 4th speed gears on layshaft

Check that the surface contacted by the cages is not scored or nicked. Replace the bushing if not perfectly smooth.

Roller cages for 1st, 2nd, 3rd, and 4th speed gears on layshaft

Ensure that all rollers in the cages are in good condition or else replace the cages.

Sliding muff forks

Ensure that all working surfaces are dead smooth and not worn to such an extent as to have lost their original hardness. Also, that the pawls operating in the drum splines are not unduly worn. If so, replace the forks.

Gear selector drum

Check wear of the drum grooves contacted by the selector forks. If too worn, replace the drum.

Gear selector pawls

Check straightness and wear and replace as necessary.

Selector drum carrying rods and gearshift forks

Check straightness of the rods, ensuring they are not damaged at the surface contacted by the forks. If so, replace the rods.

Clutch shaft

Inspect splines, threaded sections, and slots. If worn or damaged, replace the shaft.

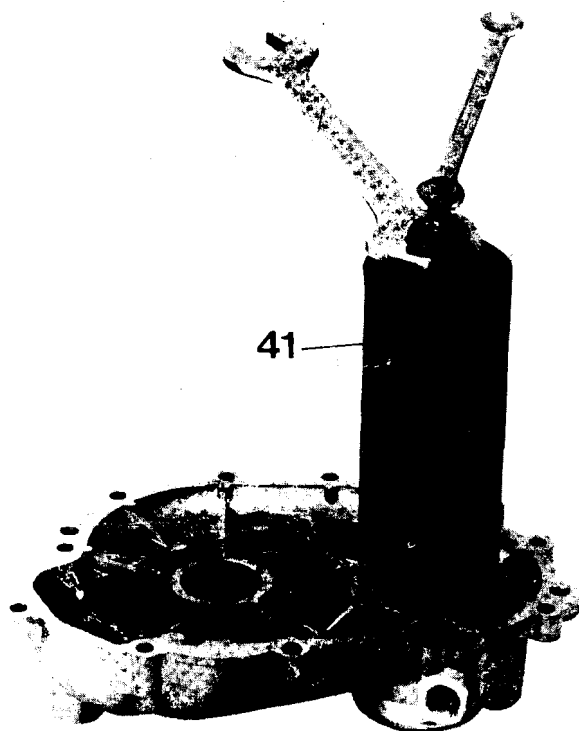

102

Inner body retaining lockring to clutch shaft

Ensure the threaded portion is undamaged or else replace the locking ring.

Lockplate for fixed body locking to shaft

Make sure its ears are still in good state and replace if necessary.

Seal between clutch fixed body and bearing on clutch shaft

If crumbled or has lost its efficiency, change the seal.

Inner clutch fixed body on shaft

Check if any teeth are broken or excessively worn. All teeth surfaces should be very smooth.

Cush plate retainer on clutch shaft

If deformed, scored, or nicked, change the retainer.

Cush plate on shaft

Needs no maintenance except making sure that its inner grooves are quite smooth.

Cush spring on shaft

Ensure it is still efficient and not deformed. When compressed to 37 mm (1.45"), load should be 190 kg (308 lbs).

Coupling sleeve on clutch shaft

Check smoothness of the internal splines and wear at the engaging end.

Idler gear on clutch shaft

Should not show excessive wear of the teeth. Teeth contact surfaces and inner grooves should be quite smooth. If not, replace the gear.

Gear selector

Check the pin on the drum pawls. If hardened or if the two pawls do not slide freely in their seals, replace the selector.

Oil leakages from the gear box

After determining that the oil leaks from the gear box, proceed as follows:

1 Porosity

If the leakage is due to porosity, this can be remedied on an assembled gear box as follows:

- secure the clutch operating lever to the gearbox by means of a rubber band;
- set up the complete gear box on a bench with the clutch housing turned upwards;
- fill up the clutch housing with water and holding

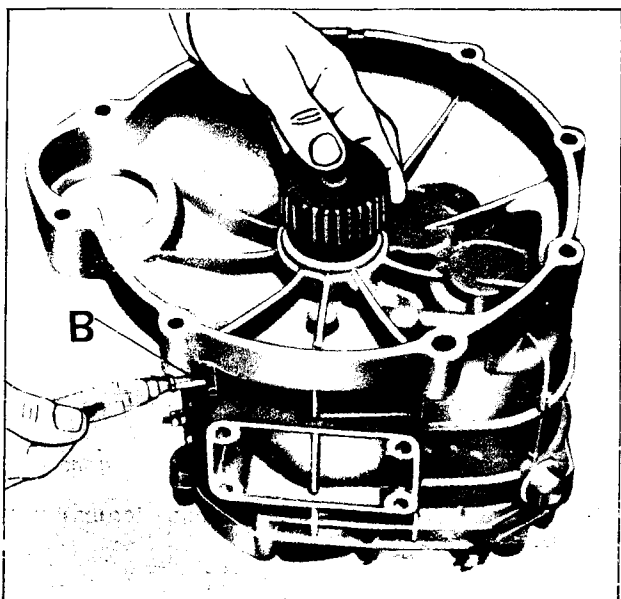

103

the seal with your fingers, blow compressed air through the hole in the breather plug (see fig. 103). If there are any blowholes in the casting, bubbles will appear in the water. In such a case, mark the position and seal up the hole with compound 00 01 02 00 (58 fig. 35).

2 Oil seeps through between clutch seal and inner body

- empty the clutch housing, lubricate the O'ring and holding the seal with your fingers, blow compressed air through the breather vent and watch if any bubbles form between seal and inner clutch body.

If required, it is necessary to change the seal or the fixed clutch body.

3 Oil seeping through between clutch body and shaft

Check the two seals on the clutch shaft.

4 Oil seeping through between clutch shaft and operating rod

Ensure the rod is straight, not scored, bent, or damaged. Make sure both taper bushings are correctly fitted (see «A» in fig. 103/1).

If these have lost their elasticity or have crumbled, replace them. Oil leaking from here may drop on the clutch plates and cause clutch slipping.

5 Oil seeping through the O'ring in cover and selector spindle

Check the efficiency of this seal. If crumbled or has lost its elasticity, replace it.

6 Oil leakage between the thrust bearing carrying the outer body, and cover

Check smoothness of cover housing and that the seal on the outer body has not crumbled or has lost its elasticity. Replace, as necessary.

17.3 ASSEMBLING THE GEARBOX ON THE BENCH

After all parts have been inspected, checked and/or replaced, the gearbox unit is assembled as follows:

▪ Bearing in gearbox and cover.

As a first operation, the bearing housings and races should be thoroughly cleaned with a solvent, preferably thychloroethylene. Then, using a loctite soaked brush, lightly smear the outer races of the bearing housings in the gearbox and cover. Make sure that no loctite enters into the balls and/or rollers.

The bearings to be fitted with loctite are:

- clutch shaft bearing in gearbox;
- layshaft bearing in gearbox;
- layshaft bearing in gearbox cover;

Use loctite N. 00 01 04 00 (59 in fig. 35).

Pressing of bearings in the gearbox housings

- After smearing with Loctite, the clutch shaft bearing is pressed into its housing by means of punch N. 14 92 89 00 (43 in fig. 104).

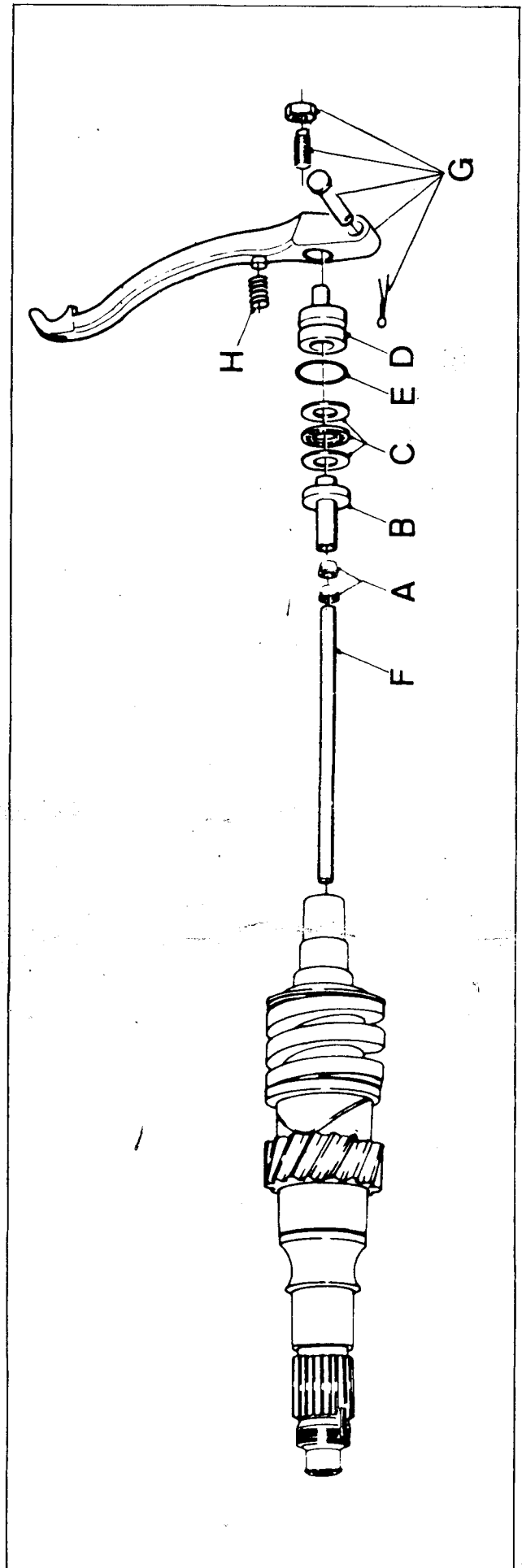

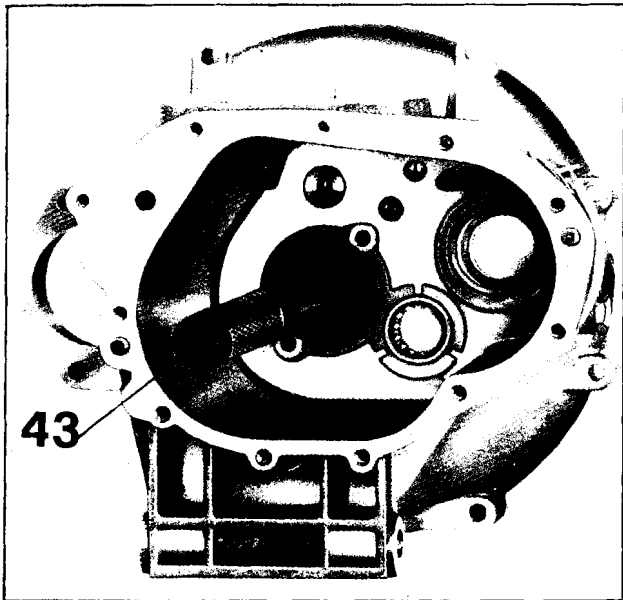

104

- The outer race of layshaft bearing is pressed in by the aid of punch N. 14 92 91 00 (44 in fig. 105).
- Main shaft bearing is pressed in with punch 14 92 88 00 (45 in fig. 106).

Pressing of bearings in gearbox cover housings

After smearing with Loctite, press the layshaft bearing in its housing by the aid of punch 14 92 89 00 (43 in fig. 107).

The main shaft bearing is pressed in with punch 14 92 90 00 (46 in fig. 108).

The clutch shaft bearing is pressed in with punch N. 14 92 88 00 (45 in fig. 109).

After pressing the bearings into their housings, leave them to rest for about 12 hours to allow the Loctite compound to dry up completely before proceeding with re-assembling the other gearbox components

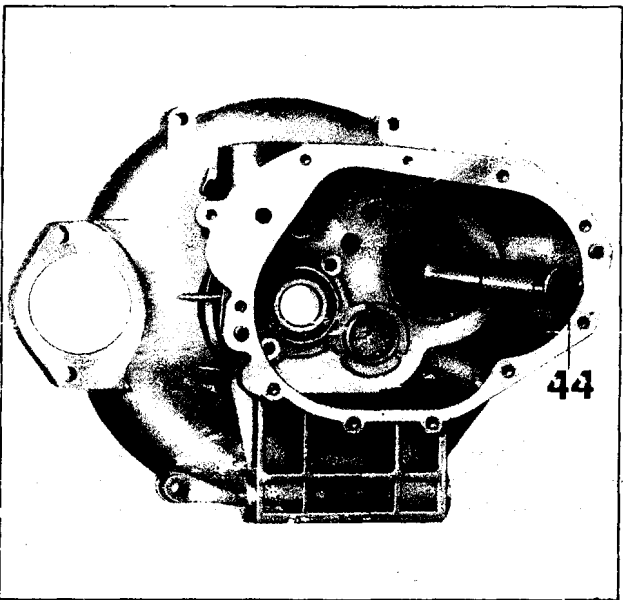

105

Assembling the clutch shaft bearing retainers in the gearbox and the layshaft bearing retainers in the cover

Ensure these retainers are perfectly adherent to the bearing outer race. The threaded portion of the retainer bolts should be smeared with Loctite N. 00 01 04 00 (59 in fig. 35) before tightening.

Fitting of gearbox seals for clutch shaft and seals in cover for layshaft and selector shaft

The seal for the clutch shaft in the gearbox is fitted using punch N. 14 92 94 00 (47 in fig. 110).

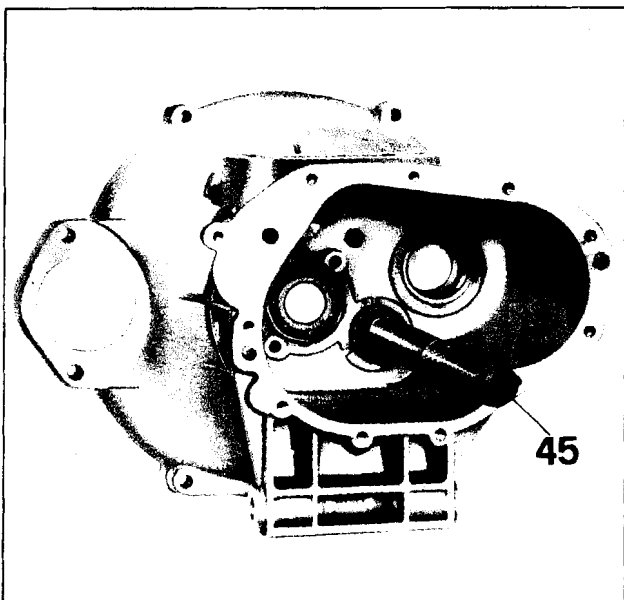

106

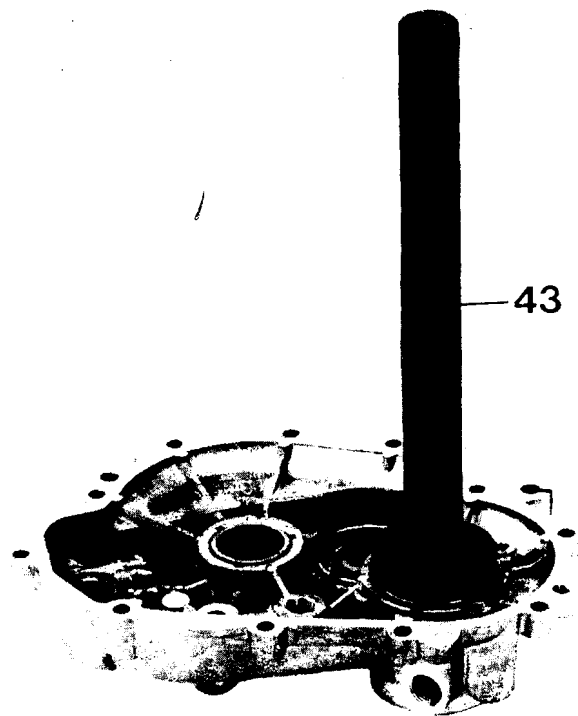

107

The seal on the gearbox cover for layshaft is fitted using punch N. 14 92 95 00 (48 in fig. 111). The selector shaft seal has to be inserted in its housing on the gear box cover ("A" fig. 111).

Fitting the selector assembly in gearbox cover
(«A» fig. 111/1)

Fit spring «A» on the selector spindle as shown in fig. 111/1. Using a suitable tool, adjust distance «B», according to the spindle diameter.

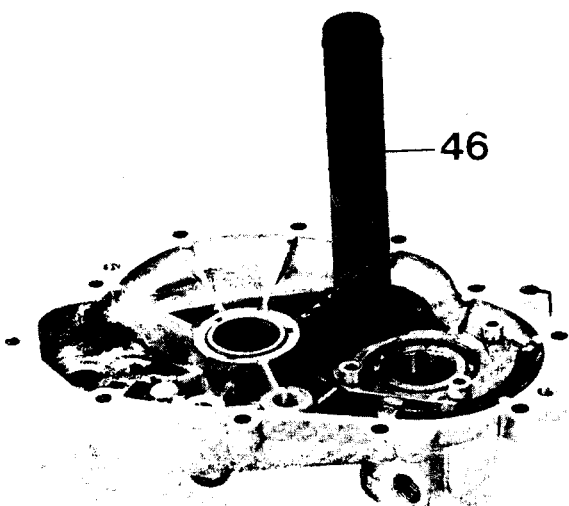

108

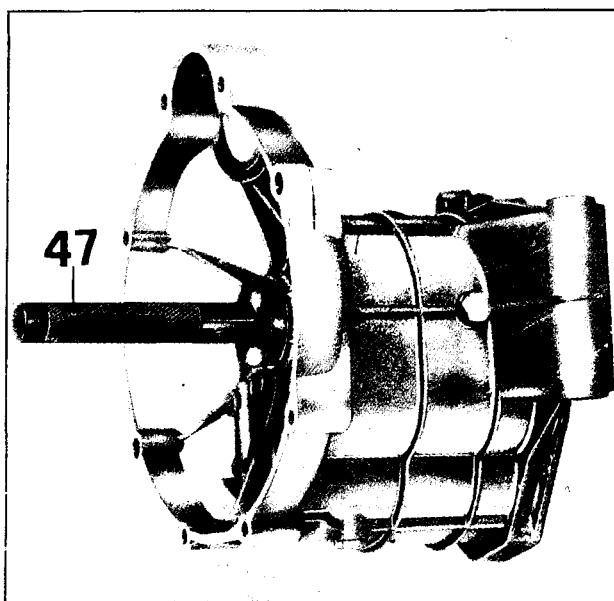

110

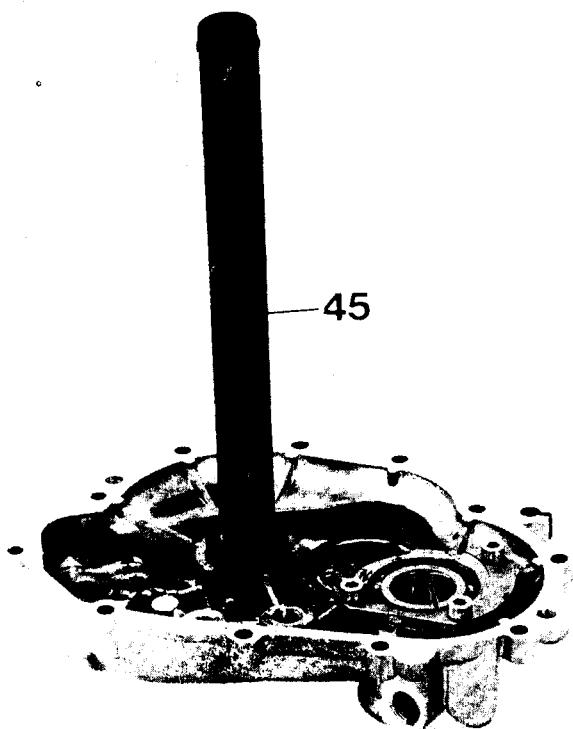

109

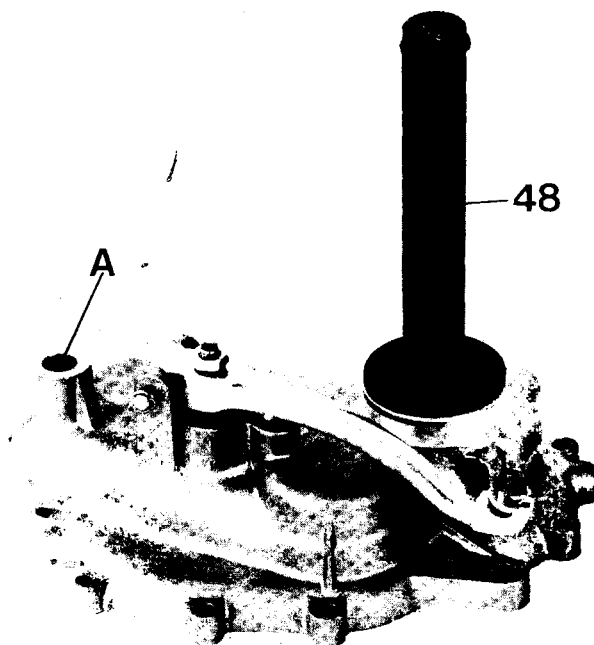

111

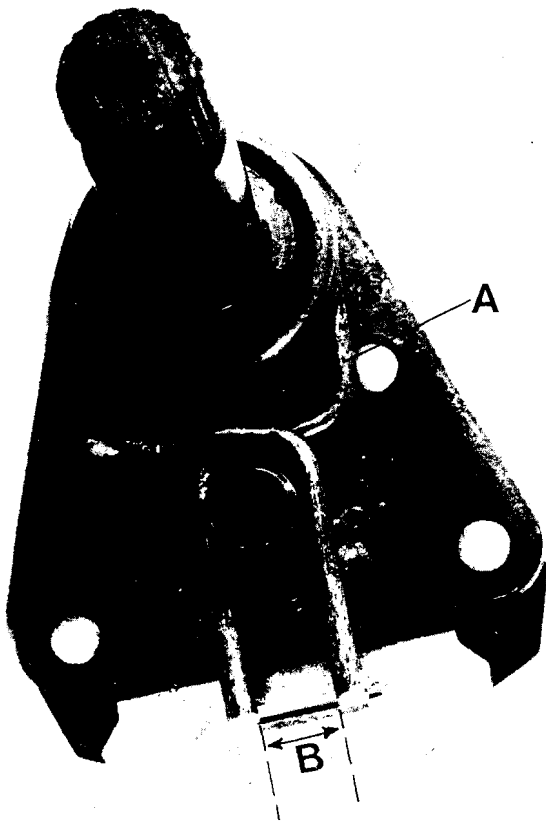

Then fit the selector spindle on the cover and tighten eccentric screw «B» with locknut «A» on the cover (fig. 118).

Re-fitting the gearbox components

All parts to be fitted in the gearbox are assembled with the following sequence:

Re-fitting the main shaft in the box

Before re-assembling the main shaft in the box, it should be shimmed so that between the gearbox bearing and cover bearing there is a distance of 167.1-167.2 mm (6.578-6.582") (see fig. 112). This distance is obtained with shims which are available in the following sizes 2-2.1-2.2-2.4 mm (.078-.082-.086-.094") (see fig. 112). The shims are fitted between the gearbox bearing and the throwout bearing. After shimming, press the roller bearing race on the shaft using tool part N. 17 94 54 60 (32 in fig. 113).

Layshaft

Before assembling this, it is necessary to fit on it the sliding sleeves and gears as follows:

On the shaft, gearbox end

- insert the second speed gear bushing on the shaft, making sure the bush head faces the gear box cover;
- roller cage for the 2nd speed gear on bushing;
- 2nd speed gear on the cage with front engaging dogs turned towards the gearbox cover;
- shim between 2nd and 3rd speed gear;
- 3rd speed gear and roller cage with its engaging dogs facing the gearbox cover;
- roller cage for 3rd speed gear on bushing;
- 3rd speed gear bushing with its head facing the sliding sleeve;

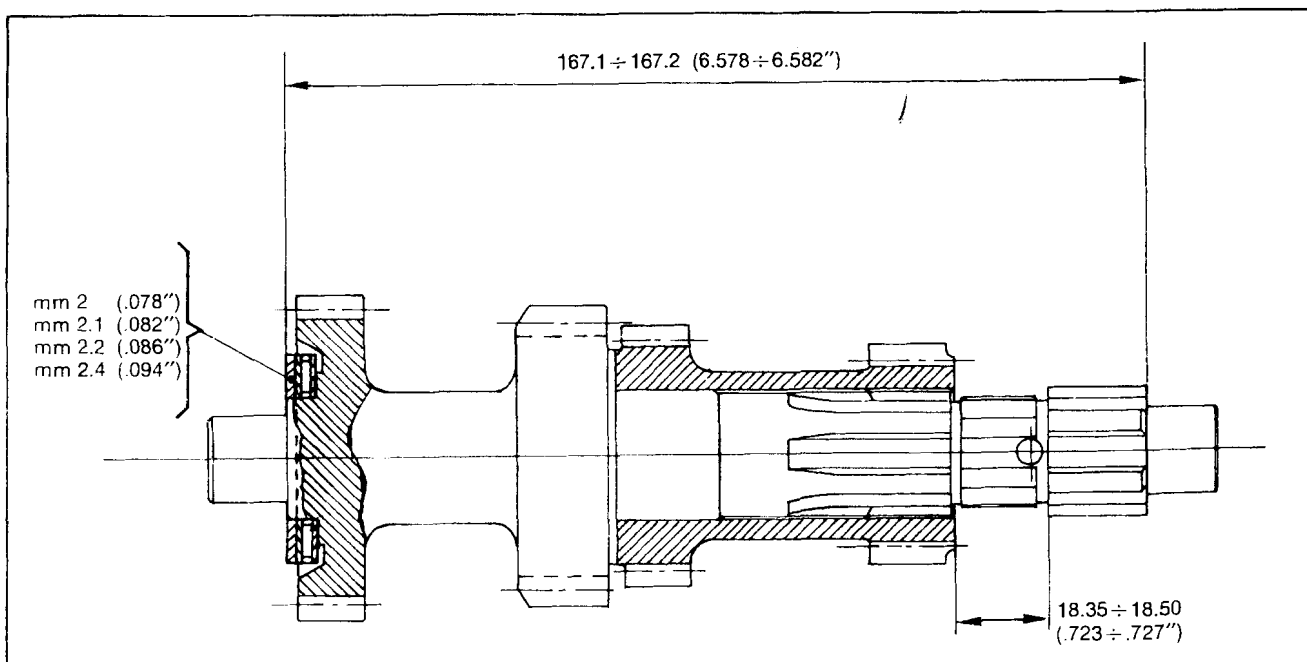

- fixed sleeve on shaft, ensuring the stepped down end faces the 3rd gear;
- the inner race of the 4th speed gear using tool 14 94 86 00 (49 in fig. 114);
- sliding sleeve for 3rd and 4th gear engagement with the stepped down end facing the 3rd speed gear;
- the complete roller cage on bushing;
- 4th speed gear, ensuring the front engaging dogs face the sliding sleeve;

On the shaft gearbox cover end

- sleeve for engaging 1st and 2nd speed gear;
- bushing for low speed gear with bushing head turned towards the 2nd speed gear;
- low speed gear on cage;
- roller cage on bushing for low gear;
- seal on shaft groove;
- high speed gear with stepped down end fitted in the seal.

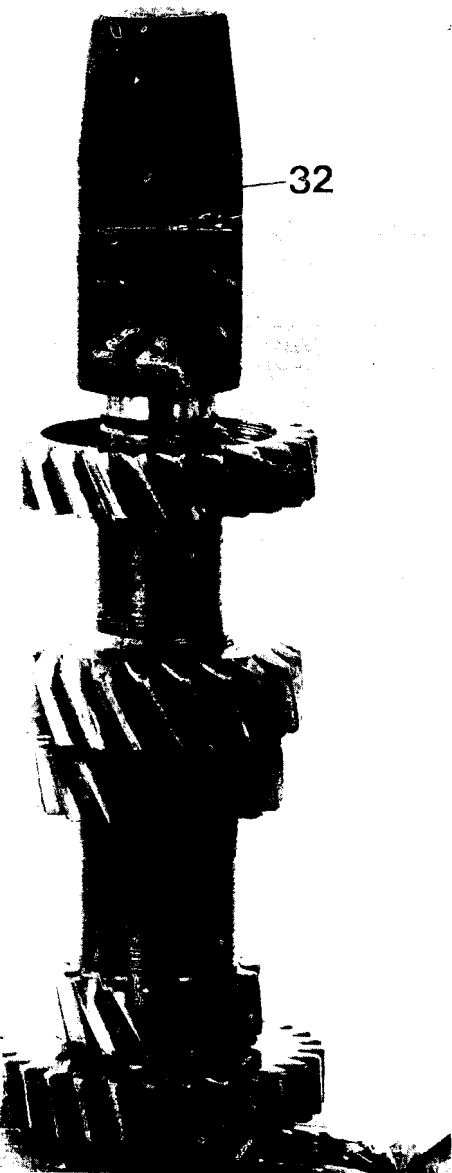

113

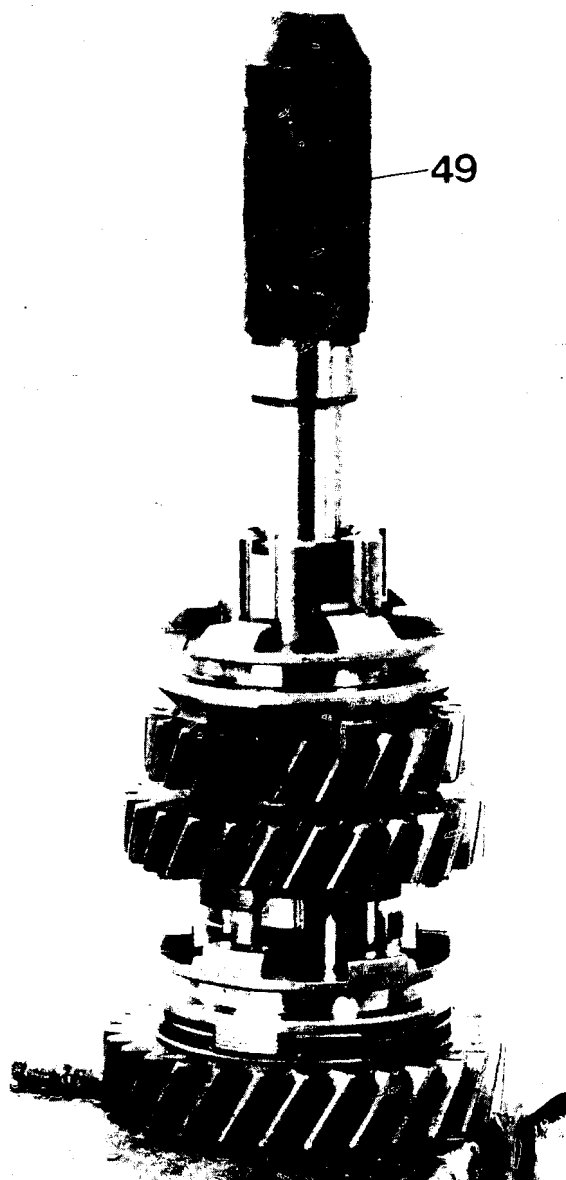

114

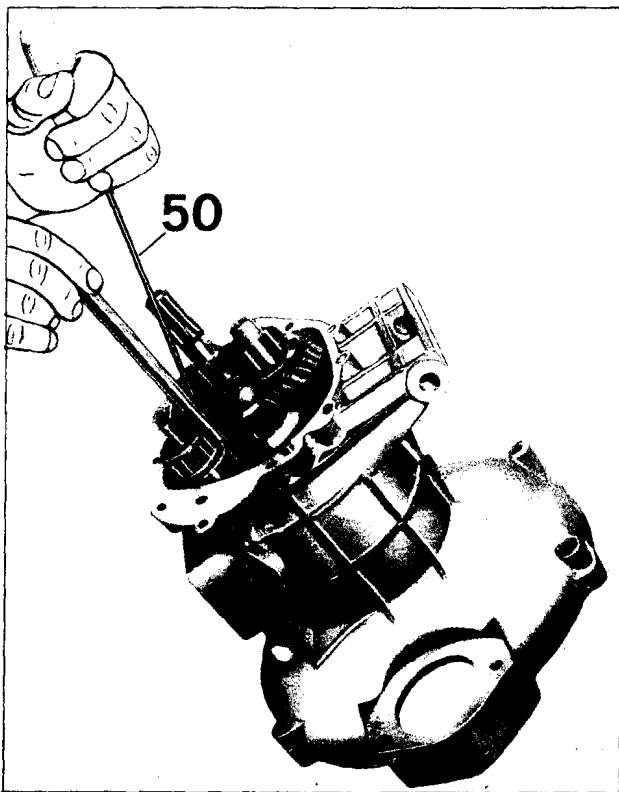

115

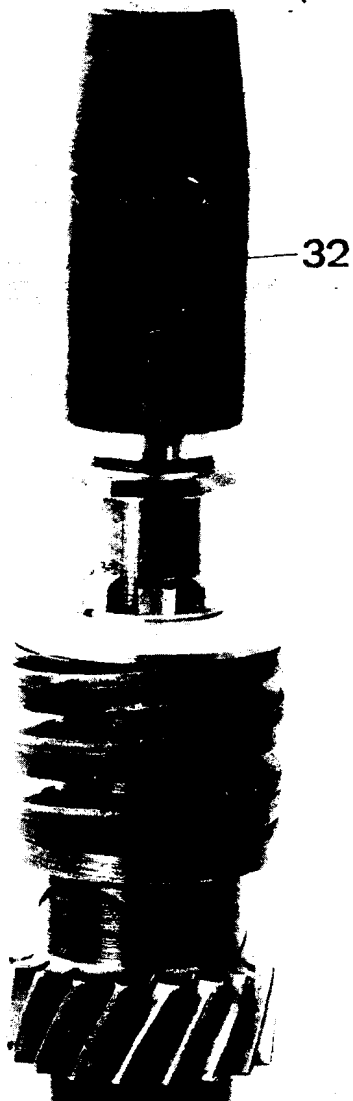

116

Shimming the layshaft

Fit adjusting washer at the 4th speed gear side and add shims until between these and the high speed gear there is a distance of 144.7-145.2 mm (5.692-5.715").

For this measurement remove «O» ring in between the 1st and 2nd gears (see fig. 92).

Fit roller bearing on shaft at the 4th speed gear side (fig. 90).

Tighten the nut on the shaft at the 4th speed gear side smearing its thread with Loctite and hammering on the nut tang with a chisel in correspondence with the shaft groove in order to form a stop for the nut. Fit now the complete layshaft in the gearbox

Gear selection forks and selector drum in gearbox

Before re-fitting the splined drum, it is necessary to measure the distance existing between the two side shoulders from box to cover. This measurement is taken with a depth gauge and should include the gasket thickness as well.

After fitting the striker fork spindle the 1 mm standard washer on the clutch housing side (See fig. 119) and the spindle retainers on the other side, measure the overall length of the complete drum assembly. On the spindle retainer add a shim of such a size as to obtain an overall length of the clutch assembly lower than 0.2 - 0.3 mm (.0078 - 0.118") the previously measured backlash.

Introduce now the complete drum assembly in the box and fit:

- The low, 2nd, 3rd, and 4th speed selector forks on the layshaft sliding muff.
- The splined selector drum complete with rod in its housing in the gear box with a 1 mm spacer (.0039").

Looking through the orifice in the ratchet pawl, it should be ascertained that one of the 6 slots in the drum is in axis with the pawl hole.

- The fork fingers in the drum grooves. To position these in the grooves, use special tool part N. 14 92 92 00 (50 in fig. 115).
- The dowel in the gearbox drilling, also the spring, and screw on the plug provisionally.
- The fork retaining rod into the fork holes
- Assemble the neutral indicator unit in the gearbox, ensuring that the blade contacts the button in the drum and the bent side is facing the clutch shaft.

Refitting the clutch shaft

First of all assemble the following parts on the shaft:

- idle gear with engaging teeth facing the gearbox cover;
- coupling sleeve with its engaging dogs facing the idle gear;
- spring on muff;
- cush spring plate;
- using special tool 12 90 59 00 (29 fig. 96) positioned on the spring pressure plate, compress the spring until the 2 retainers can be inserted in the slot machined in the clutch shaft;

- fit spacer nut;
- fit bearing inner race in the cover using part N. 17 94 54 60 (32 in fig. 116) to press it on the shaft. On the shaft at the gearbox end fit now:
 - seal in its groove on the shaft;
 - oil scoop between shaft and gearbox bearing;
 - finally, insert the clutch shaft in the bearing on the retaining ring in the gearbox.

Assembling the high speed gear and coupling sleeve on the main shaft

Proceed as follows:

- Fit roller cage and high speed gear on bushing.
- Insert cage-bush-gear assembly on the splined section of the main shaft until it is near the hole drilled in the shaft.
- Introduce the spring in the shaft drilling and position stop pin on top of the spring.
- With the left hand thumb or with a special tool (formed by a pin and tube) keep the pin pressed down and with the right hand push bushing with cage and gear right in.
- Turn the bushing to the right or left until the stop pin clicks into one of the 6 inner grooves of the bush.
- Fit high speed engaging sleeve with selector fork

on the shaft, then the fork on the rod, inserting the fork finger in the groove on the splined drum.

Assembly of gearbox cover

NB In re-assembling the gearbox cover complete with selector unit, ensure the **selector drum is set in the neutral position** as otherwise the selector pawls might not enter freely in the two slots indicated by the arrows in fig. 117.

- Screw in the 4 cover screws lightly.
- Insert the speedo drive pin in the cover, screwing it down fully.
- On the layshaft fit: O'ring, shim, speedo drive gear, and its stop ball.
- Fit provisionally the layshaft securing nut.
- Mount tool 14 92 87 00 (51 in fig. 118) on the selector shaft.
- Adjust the gearshift control by means of screw «A», after having undone locknut «B» in fig. 118 until gear engagement is smooth.
- Check gear engagement by changing up and down from low to high speed and feeling for the neutral position. If gearshifting presents some difficulty, take the gearbox cover down again and remove or add some shims between drum and gearbox, if the difficulty lies in engaging low and 3rd gear,

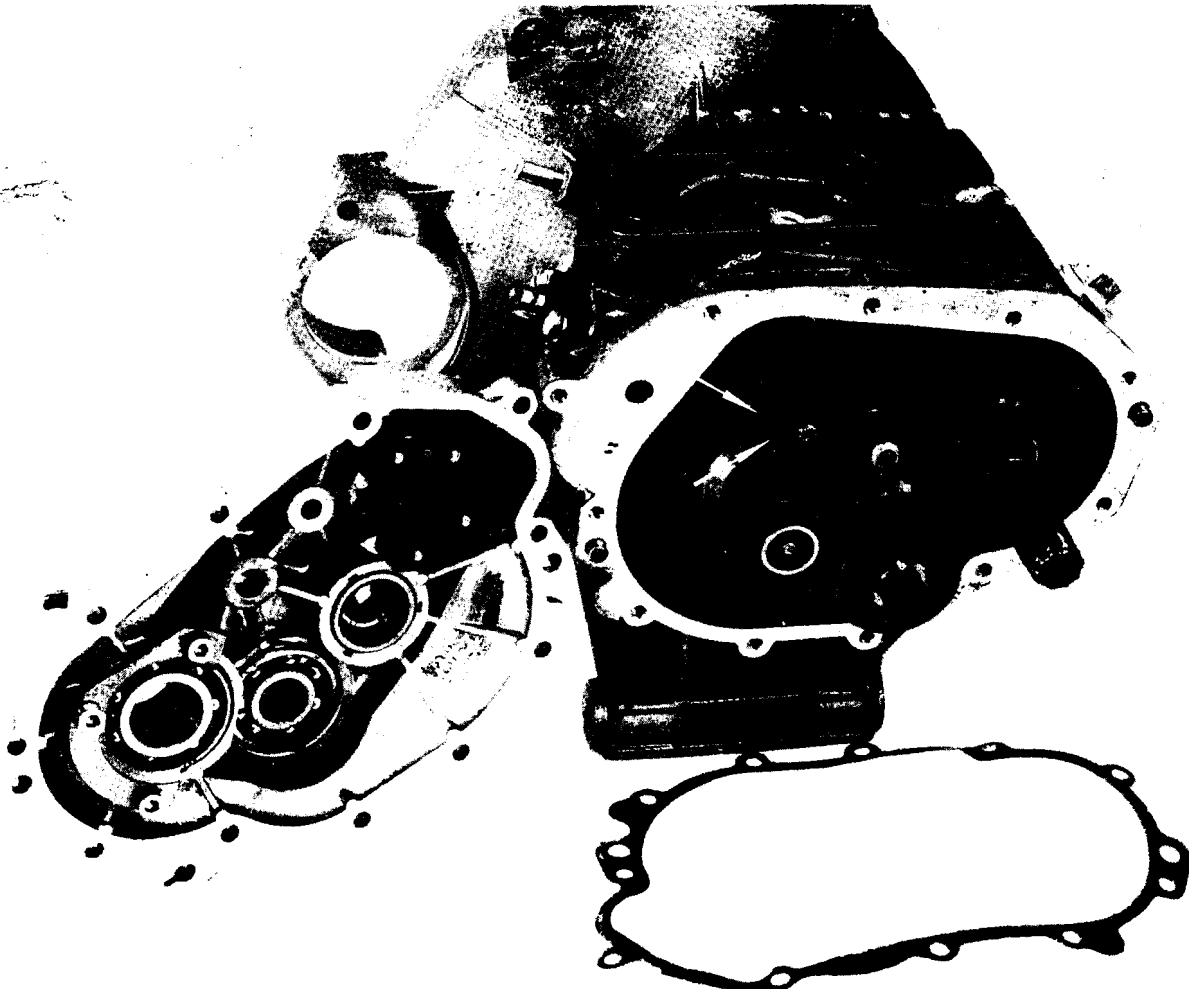

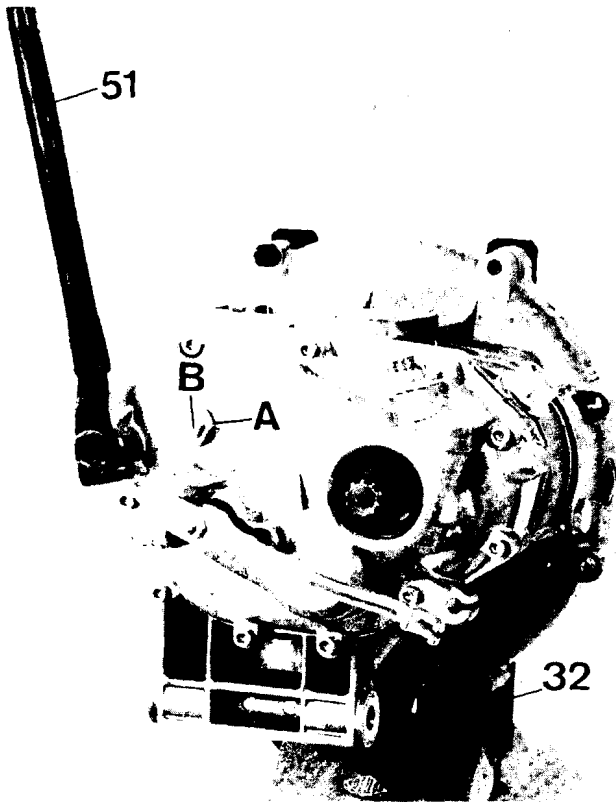

118

and between gearbox cover and drum, if 2nd and 4th gear do not engage smoothly.

Shim sizes available for this operation are: 0.6, 0.8, 1, and 1.2 mm (.023, .031, .039, .047") see fig. 119.

After shimming refit the cover as above described and check again if all gears engage properly.

If so, lock the layshaft nut tightly using tool N. 14 90 54 00 (35 in fig. 91) and layshaft holdfast tool 12 90 71 00 (34 in fig. 91).

After tightening this nut, hammer it with a chisel in correspondence of the shaft groove to lock it completely.

Tighten the cover securing screws and remove the tool previously fitted on the selector shaft. Insert the operating lever in the selector shaft and tighten its securing screw.

Lock tightly the oil breather plug which is also the retainer of the spring and stop pin on the gearbox.

Refitting the inner body and clutch unit on shaft

Assemble:

- bearing-inner body seal;
- inner body;
- safety washer;
- inner body locking nut on clutch shaft. Tighten this nut using tool N. 14 91 28 00 (36 in fig. 94) and hook wrench N. 14 91 26 00 (37 in fig. 95);
- bend one ear of the lockplate in one of the lock-nut grooves.

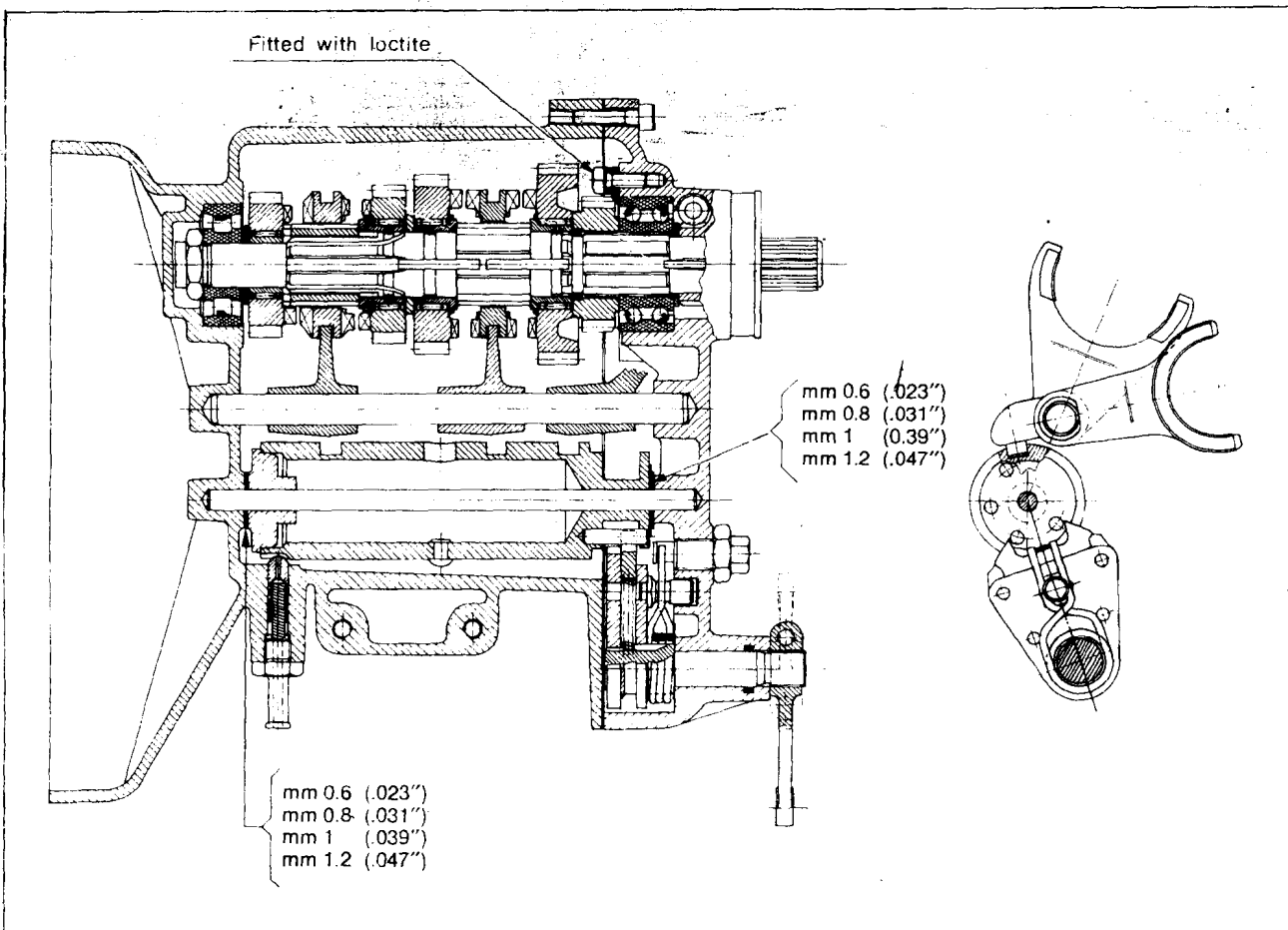

119

Refitting the complete clutch unit on the main shaft and in gearbox cover (fig. 103/1)

Refit:

- inner body «B»;
- throwout bearing «C» on inner body;
/ outer body «D» fitted with seal on gearbox cover «E»;
- control rod «F» in the shaft, gearbox side;
- complete operating lever on gearbox cover with adjusting screw and locknut, also securing locknut with cotter pins «G»;
- lever return spring «H» in its housing in the gearbox.

Fitting the complete gearbox with shafts and gears on the engine group

To assemble the gearbox on the engine proceed as follows:

- Fit the gearbox on the stud bolts of the engine, taking care that the clutch inner body matches exactly the two driven plates previously mounted.
- Screw in the stud bolts and screws.

Adjusting the clutch operating lever

After assembling the gearbox on the engine, adjust the clutch operating lever as follows:

- screw in or out adjusting screw «B» after loosening conternut «A». The distance to be obtained from the gearbox cover to the center of the round slot which retains the cable terminal is 75 mm (2.95") (see «C» in fig. 120).

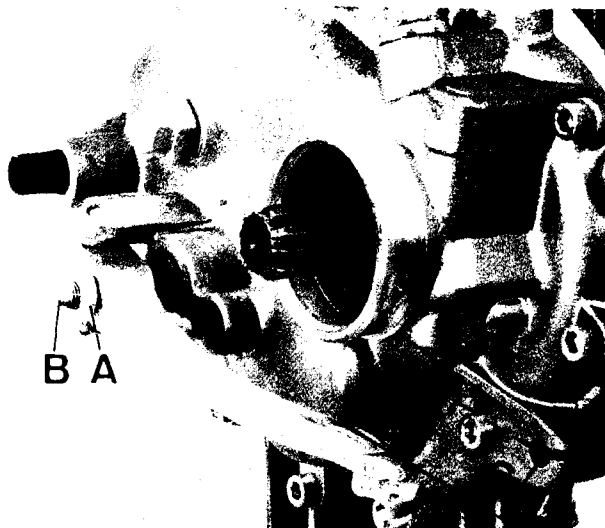

120

18 REAR DRIVE

18.1 Removing the rear drive box (fig. 121 1)

Before removing any part from this drain the oil completely.

Do this by undoing the nuts securing the box to the rear swing arm and withdrawing the box with gasket «D».

Take out the housing complete with pinion «E» and seal «F» from the housing.

Remove cover «H», gaskets «L» with spacer «M». From the hollow spindle remove the roller bearing inner race using puller 17 94 83 60 (27 in fig. 122).

From the box remove spacer «O», seal «P» and roller bearing «Q».

Remove the outer roller bearing race using puller 12 90 69 00 (15 in fig. 123).

Housing components

To remove the nut securing the pinion to the housing, use tool 12 90 71 00 (34 in fig. 124) and a hooked wrench.

From the housing remove:

- bevel pinion and its shims;
- taper bearings;
- bearing outer race by the aid of puller number 17 94 50 60 (40 in fig. 125);
- bearing spacer;
- bare housing.

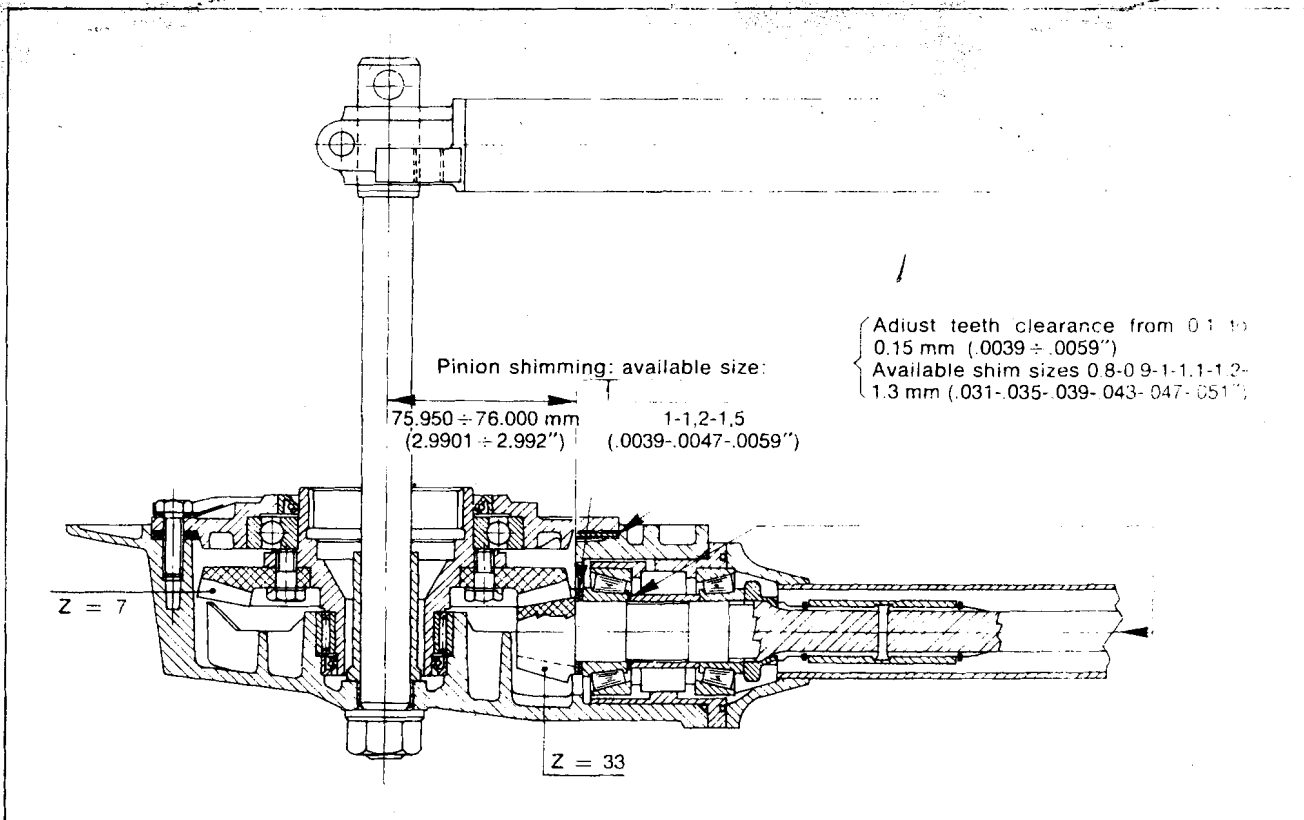

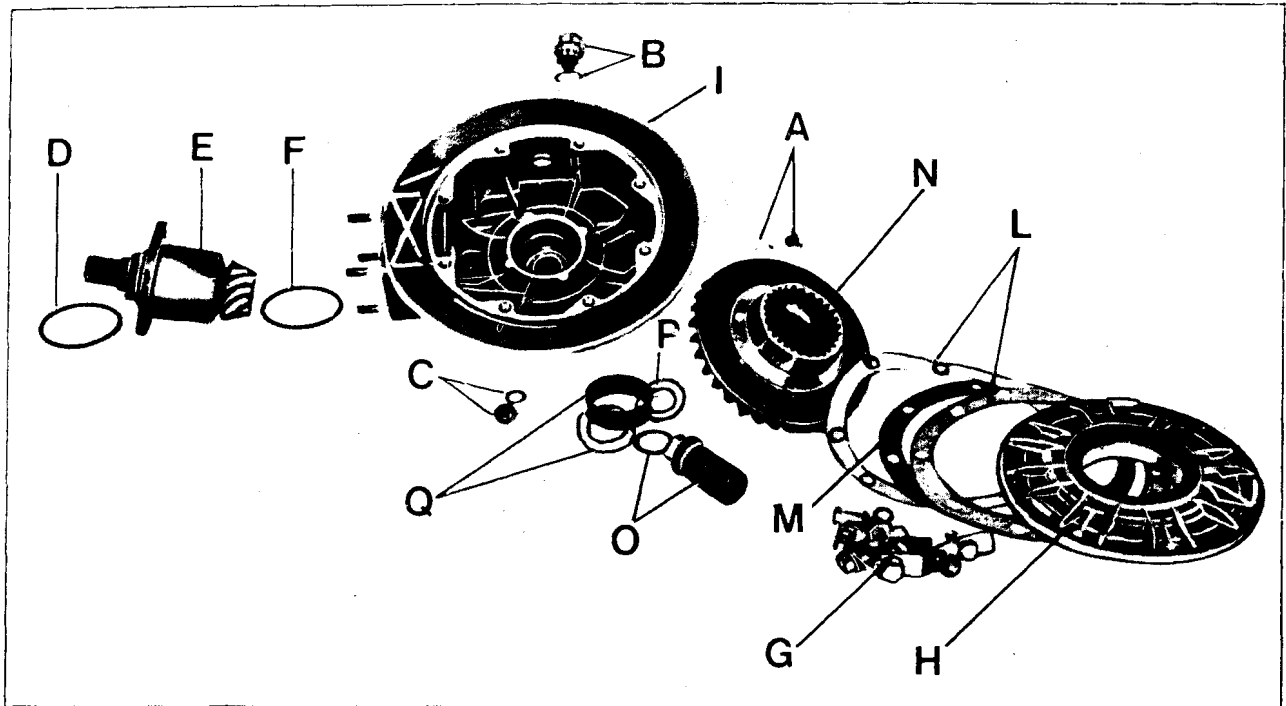

121

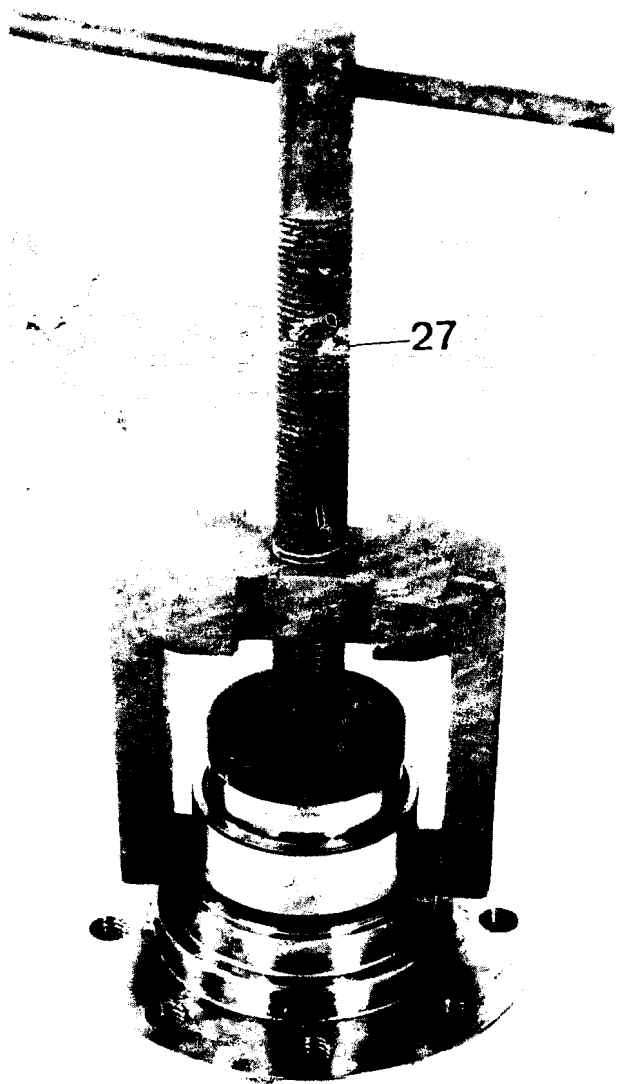

122

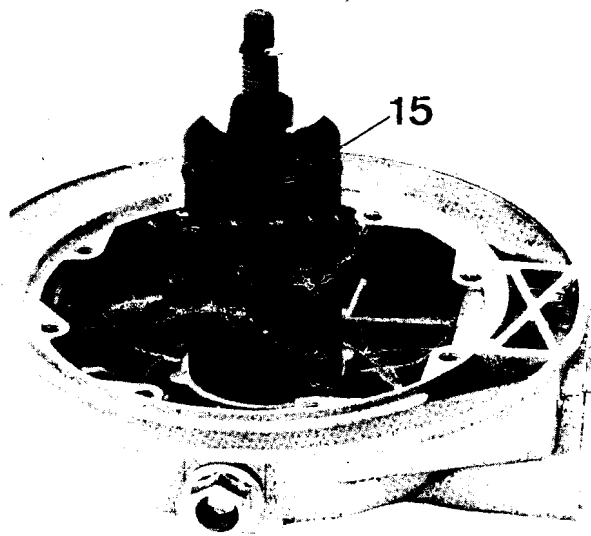

123

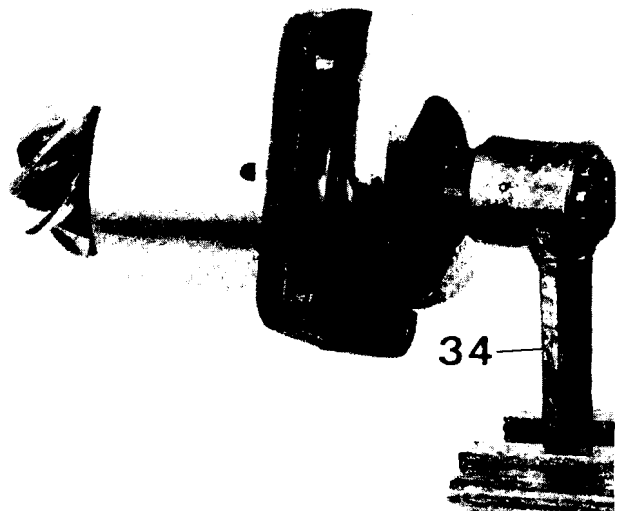

124

18.2 INSPECTION AND OVERHAULS

Drive box

Ensure that:

- there are no cracks or leakages in the casing;
- the bearing housing is not damaged or scored;
- the union faces are not scored or damaged and perfectly smooth;
- the seal rings are still efficient. Replace if crumbled or have lost their efficiency;
- all gaskets should be replaced even if they appear to be still in good condition.

Drive box flange

Ensure that:

- flange is not cracked;
- union faces are not scored or nicked;
- bearing and seal housings are not scored or nicked;
- efficiency of the seal. If crumbled or damaged, replace it.

Distance shims

Are available in 6 different sizes:

0.8 - 0.9 - 1 - 1.1 - 1.2 - 1.3 mm (.031 - .035 - .039 - .043 - .047 - .051").

Ensure the union faces are not scored or nicked.

Internal toothed spindle for rear wheel coupling

Ensure the surface supporting the ball bearings is faultless and dead smooth, also the internal teeth are undamaged.

Bevel gear set

The bevel set consists of a pinion and a «Gleason» crown wheel. Ensure the teeth of these are not chipped or excessively worn. Pinion shank should be free of scoring and the splines dead smooth.

Cage retaining ring

Make sure the contact surfaces are dead smooth and not worn.
Replace as necessary.

Rear wheel spindle distance piece

Check integrity of all contact surfaces.

Gearing housings

Ensure all coupling surfaces and the bearing housings are not scored or worn. The gaskets should always be changed.

Bearing spacer

Ensure that its contact surfaces are not damaged.

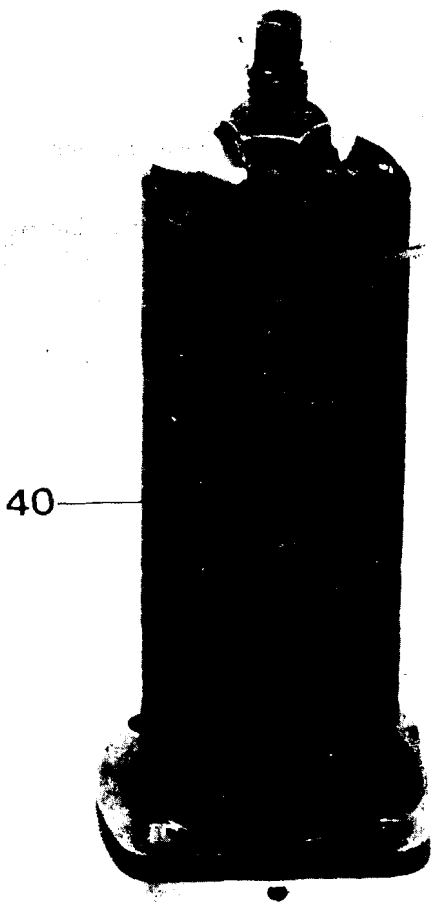

Bearing spacer shims

Are available in 2 different sizes. Check their flatness or if they are excessively worn, and replace as necessary.

Bevel set securing nut in bearing housing

Since the nut's tang was crushed to form a stop in one of the pinion grooves, when re-assembling it is always advisable to change this nut.

Rubber seals

Make sure they are still efficient. If crumbled or have lost their elasticity, replace.

Drive shaft sleeve for bevel pinion

Inspect the internal splines. If chipped or heavily scored, replace the sleeve.

Circlips on main shaft

Ensure of their perfect efficiency. If they have lost their elasticity, replace them.

Drive shaft

All splines should be in perfect state. If chipped or scored, replace the shaft.

Double cardan joint

Ensure the internal splines are dead smooth and free from chipping or scoring. Ensure that the arti-

culatation is not too slack or has hardened excessively. If necessary, replace the joint.

Gaiter retaining bands

Check for cracks or if they have lost its elasticity. Replace, if necessary.

Bevel pinion-crown wheel selection

Ensure that both pinion and wheel bear the same letter («A» or «B», fig. 126).

Oil leakages from the rear box drive

This check is done as follows:

■ Fit tool «C» on the box (fig. 127). This tool can be made up using an arm of an old swing fork (right), welding on top of it a small plate fitting an air tube valve.

1 Porosity

■ Place the box in a water full basin and blow compressed air through the valve on tool «C» (fig. 127). Any porosity will be evidenced by bubbles in the water.

After detection, these are best eliminated using Devcon «F» compound N. 00 01 02 00 (58 in fig. 35).

2 Oil leakage between seal and hollow spindle

Ensure the seal is mounted with its lips and spring facing inwards, also it has not lost its elasticity or has crumbled.

Check smoothness of the hollow spindle surface contacting the seal. If necessary, change the spindle and/or the seal.

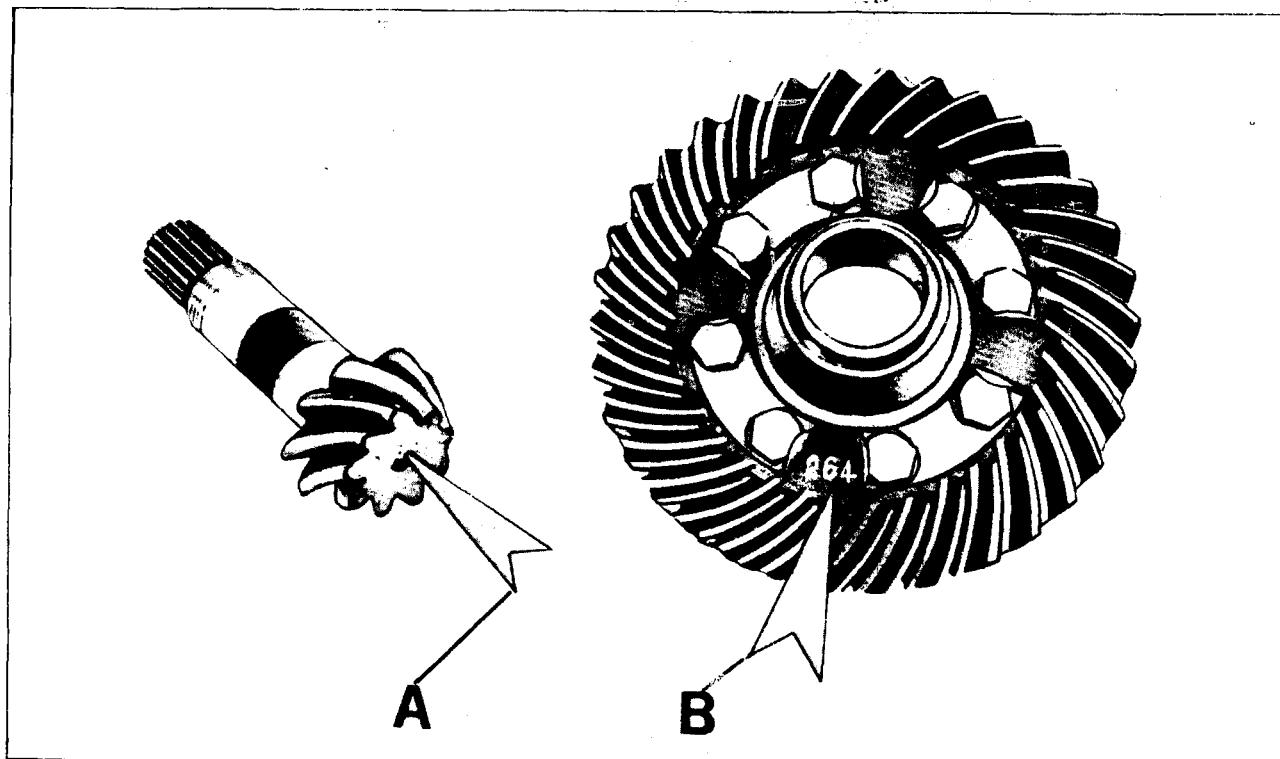

126

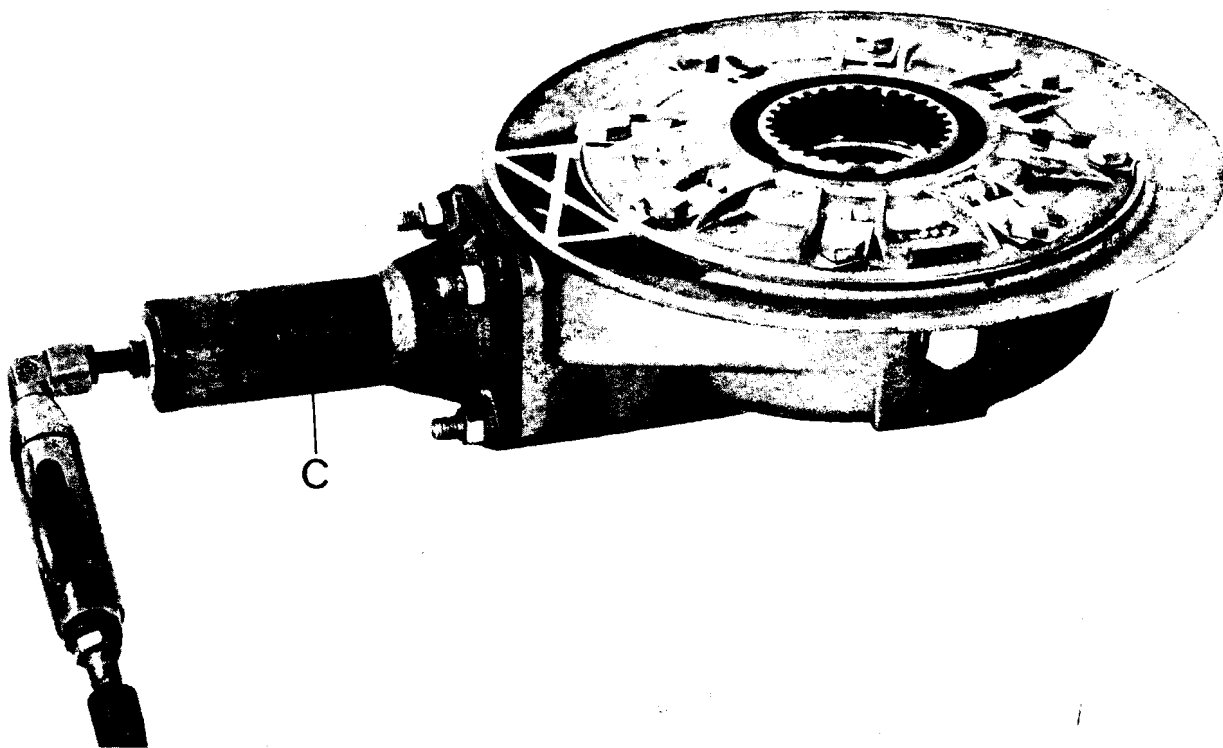

127

3 Oil seeping through the box and the bottom suspension securing spindle

If this spindle shows up oily, put some TELFLON 00 01 00 00 tape on the threaded portion (57 fig. 35).

18.3 RE-ASSEMBLY

Taper bearing outer races in the housing

These are fitted using special punch part N. 17 94 51 60 (53 in fig. 128).

Housing and its components

Assemble these reversing the dismantling sequence ensuring that if no parts have been changed, the number of shims between spacer and bearing, also between bearing and bevel gear is the same.

If any part has been replaced, a new shimming will be required.

The nut is tightened using holding tool 12 90 71 00 (34 in fig. 124) and a wrench. If properly shimmed up, the pinion should turn freely but without any play

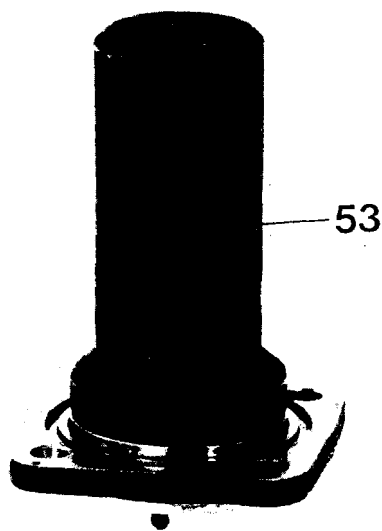

128

90

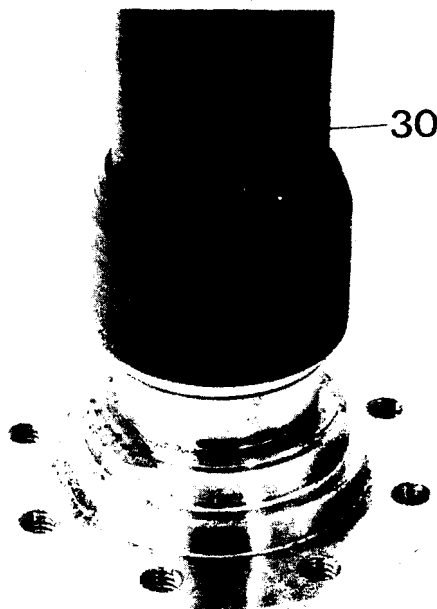

129

Pressing the inner race of the roller bearing on drilled pin

This is done by the aid of tool part N. 17 94 84 60 (30 in fig. 129).

Pressing the outer race of the roller bearing in the box

Do this using tool part N. 17 94 88 60 (56 in fig. 130).

Housing on the box (fig. 131)

When refitting housing «A» on drive box «B», ensure the oil passages in box «C» and housing «D» are perfectly lined up. Remember to fit seal «E» between housing and drive box.

Fitting the cover on drive box (fig. 132)

Proceed as follows:

- Position gasket «A» on the box, fit shim «B», and then the other gasket «A», paying attention to the alignment of the lubricating holes.

Ensure also that the wording «BASSO» (C) faces downwards and the arrow stamped on cover «D» is aligned with the arrow on box «E». Then lightly screw on the screws.

Pinion-crown coupling (see fig. 133-133/1)

Ensure the plane formed by the gear set is in perfect correspondence. Check this by:

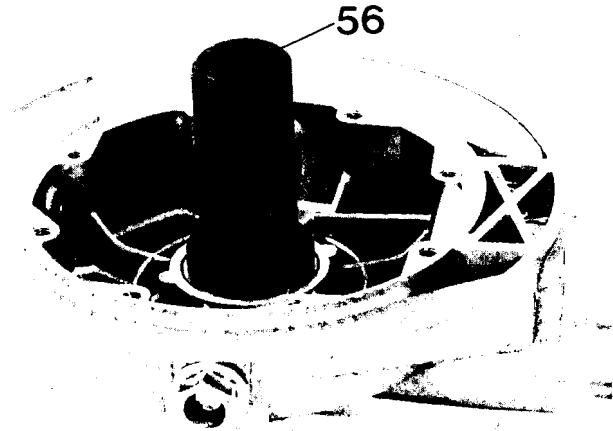

130

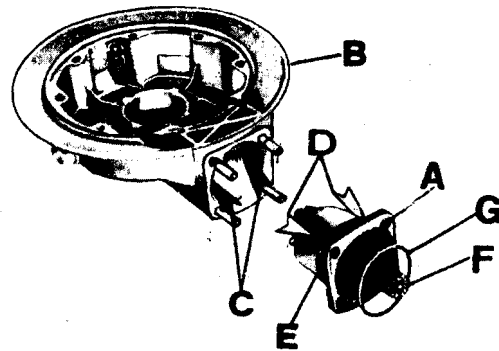

131

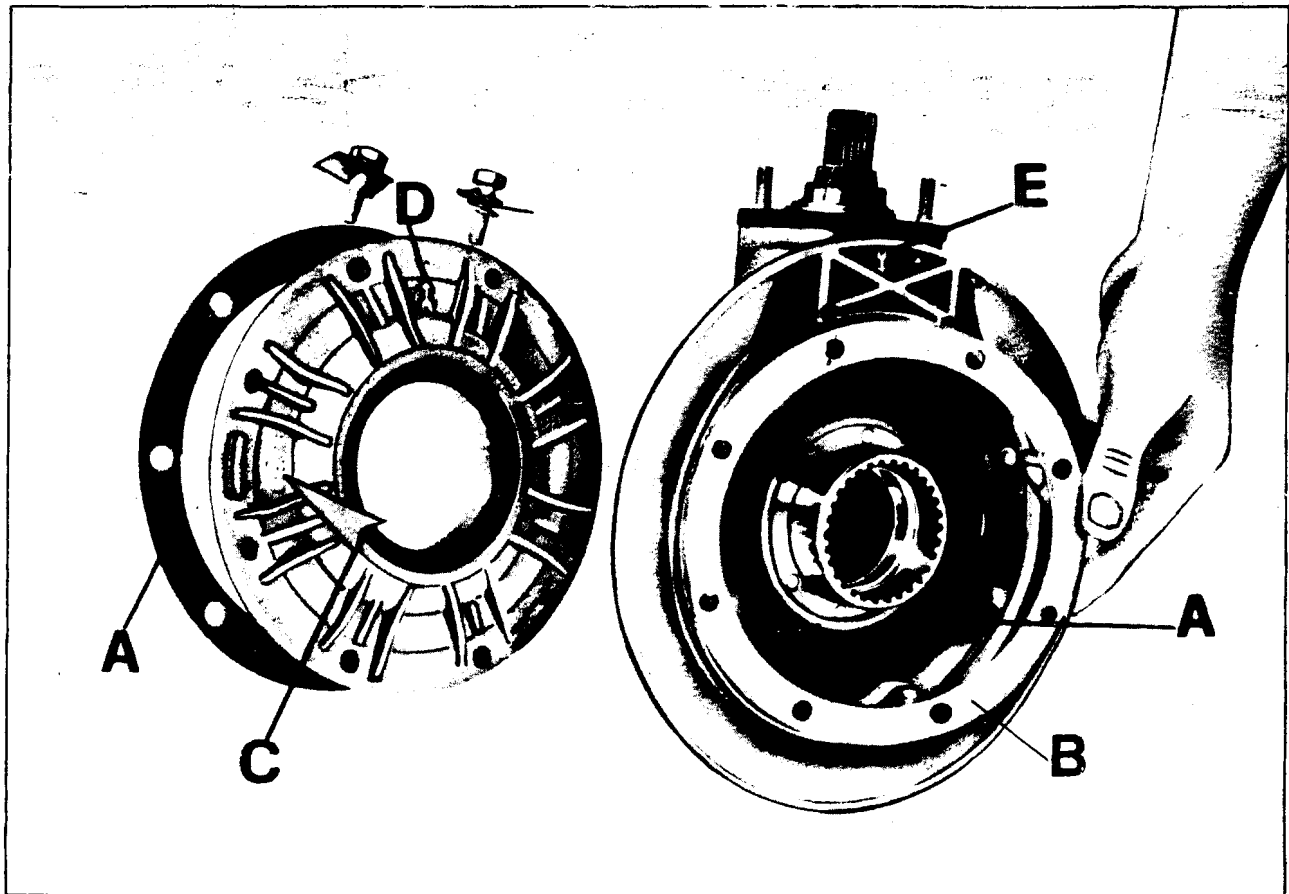

132

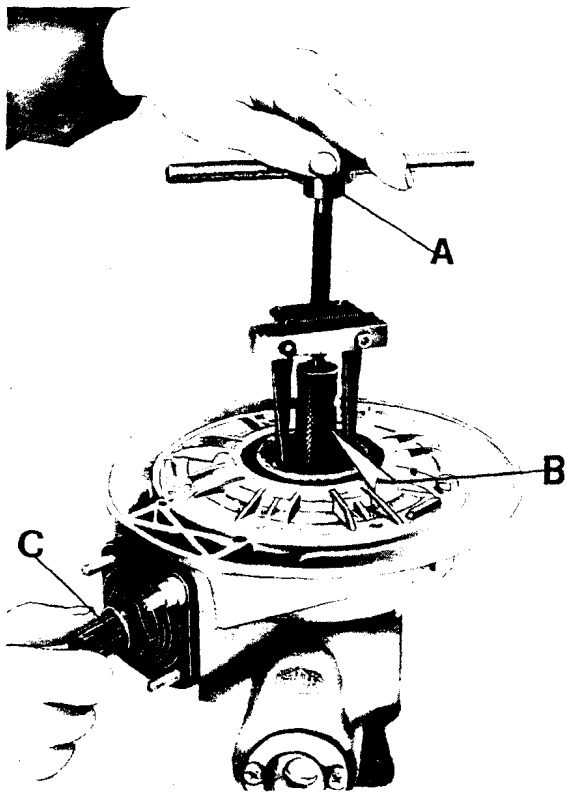

- Tighten the housing complete with pinion to the drive box using a couple of nuts «A», washers, and spacers and this only provisionally.
- Smear the crown teeth with lead oxide.
- Now provisionally set up this group (crown wheel-hollow spindle-cover gaskets and spacer) in the box, heading to the arrow and the wording «BASSO» (low side).
- Insert the legs of universal puller «A» (fig. 133) and secure them inside the drilled pin.
- In this fit a piece of light alloy «B» and screw the extractor on it.
- Now evenly rotate pinion «C», holding the crown in such way that the rotation leaves a contact trace on the painted section of the crown gear.
- Different size shims are available for this adjustment.

Checking the crown-pinion clearance

If the pinion crown contact is correct, the mark on the pinion teeth will be as shown in «1», pinion seen from driving side (fig. 134).

If the contact is as shown at «2» (fig. 134), this means the crown is too near the pinion. Move the crown wheel away from the pinion and increase the shim thickness.

If the contact is as shown at «3», the pinion is too near the rotational axis of the crown. Move away the pinion and reduce thickness of the bearing-pi-

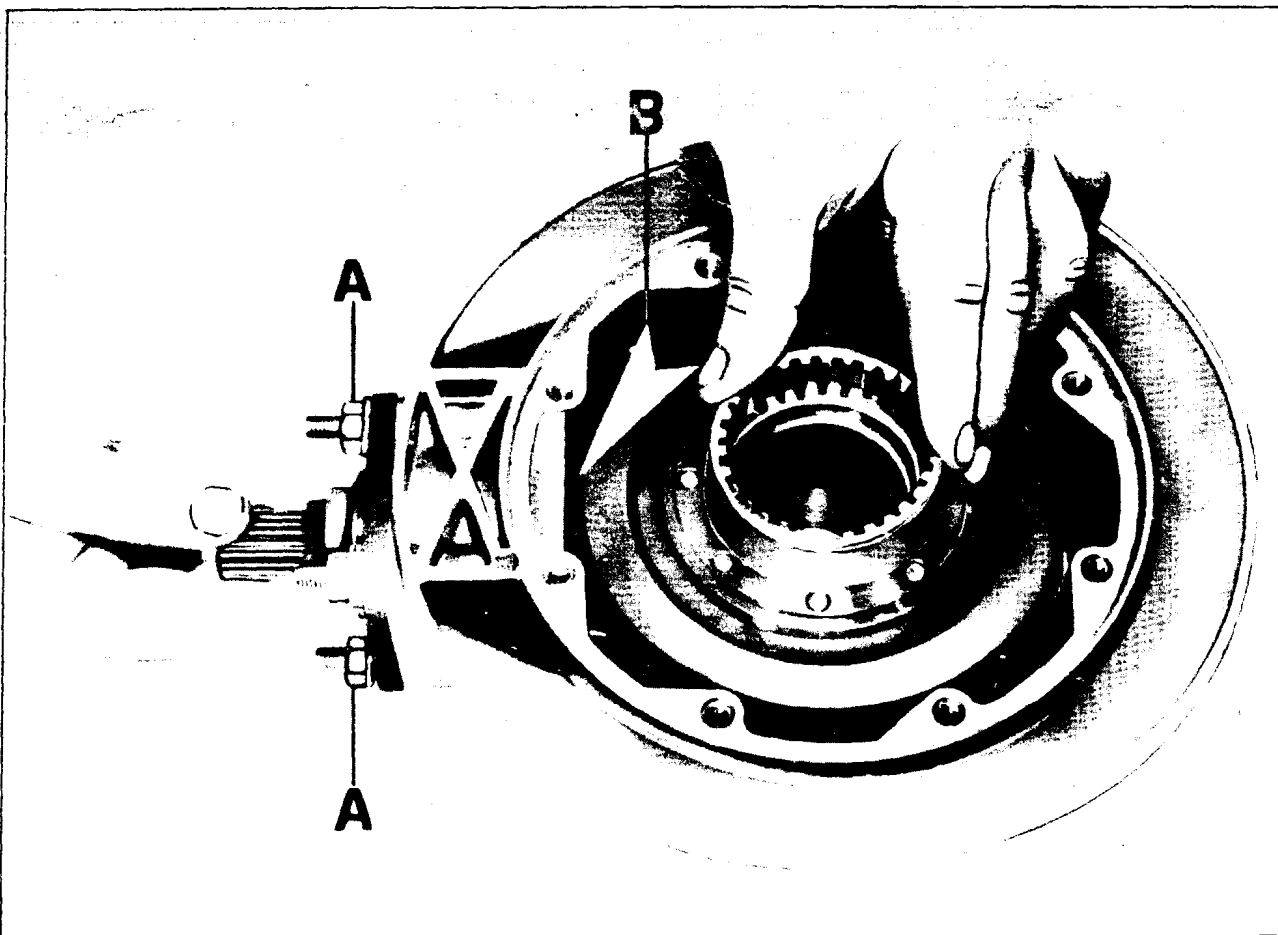

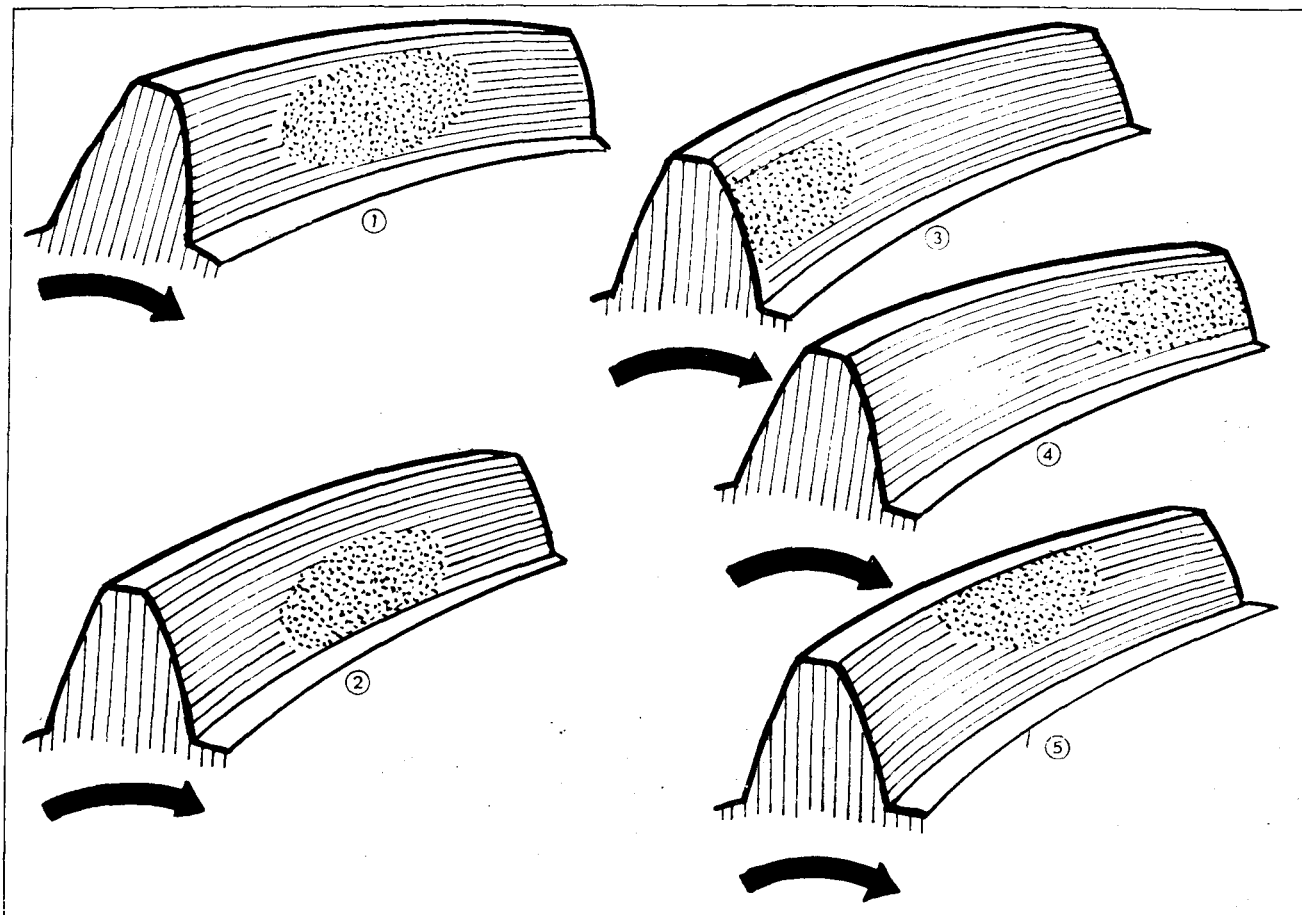

134

nion shim (see arrow «B» fig. 133/1).

If the contact is as shown at «4» (fig. 134), the pinion is too far from the rotational axis of the crown. Move pinion nearer to the crown and increase thickness of the bearing-pinion shim (see arrow «B» fig. 133/1).

If the contact is as shown at «5» (fig. 134), the crown is too far away from the rotational axis of the pinion.

Approach the crown and reduce thickness of the box-cover adjusting shims. With a correct contact, the pinion-crown clearance should be 0.10-0.15 mm (.0039-.0059").

Assembling the box on the R/H arm of the swing fork

- Fit the wheel spindle spacer in the box.
- After fitting the sleeve and spindle on the pinion, position the seal on housing «G» (fig. 131), and slip the rear drive box complete with shafts on to the double cardan joint and the 4 studs in the holes of the swing fork right arm «A», fig. 134.
- Insert rear wheel spindle «B» (fig. 134/1) through the L/H arm of the rear fork and the drive box.
- Tighten nuts «C» (fig. 134/1) with their washers. Then withdraw wheel spindle «B» which should come out effortlessly.

If it offers any resistance, it is necessary to loosen nuts «C» and turn the box to the right or to the left until the spindle can be withdrawn from the box and the swing fork arm without any effort.

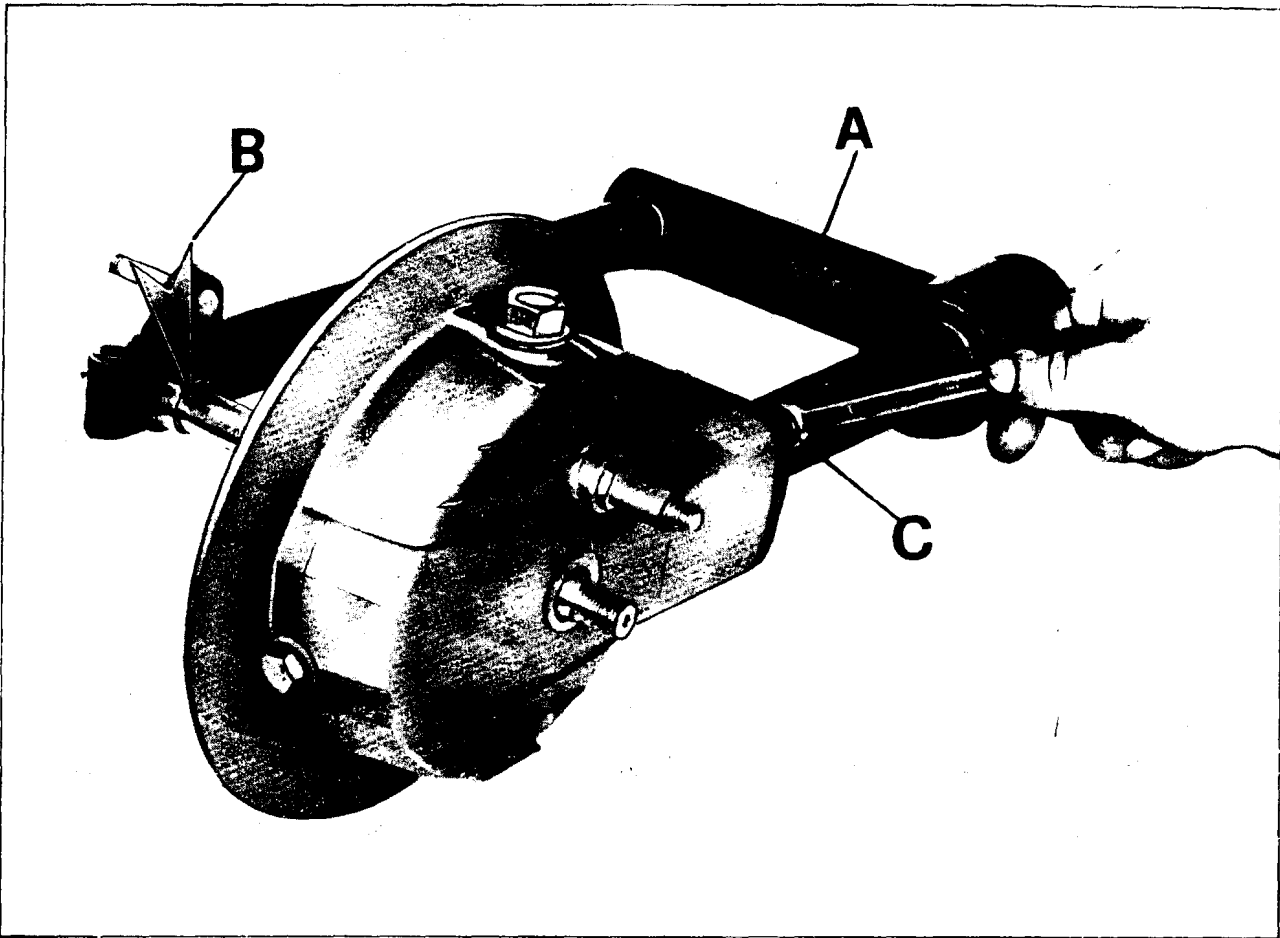

134/1

19 FRAME

Two parts make up the frame: one is of conventional type and the other is formed by two bottom members which carry the engine, i.e. the cradle.

A Inspecting and overhauling the frame

After an accident, the frame should always be checked over for deformations, cracks, etc. against the sizes indicated in drawing page 135.

B Center stand return spring

Ensure it has not lost its elasticity.
Under a load of 30 kg \pm 5% (62 lbs), the spring should extend 10 mm (.39").
Free length is 94-95 mm (3.70-3.74").

C Side stand return spring

Be sure it is still efficient.
Under a load of 10.2 kg (22 lbs), the spring should extend 7 mm (.27"). Free length is 183 mm (7.20").

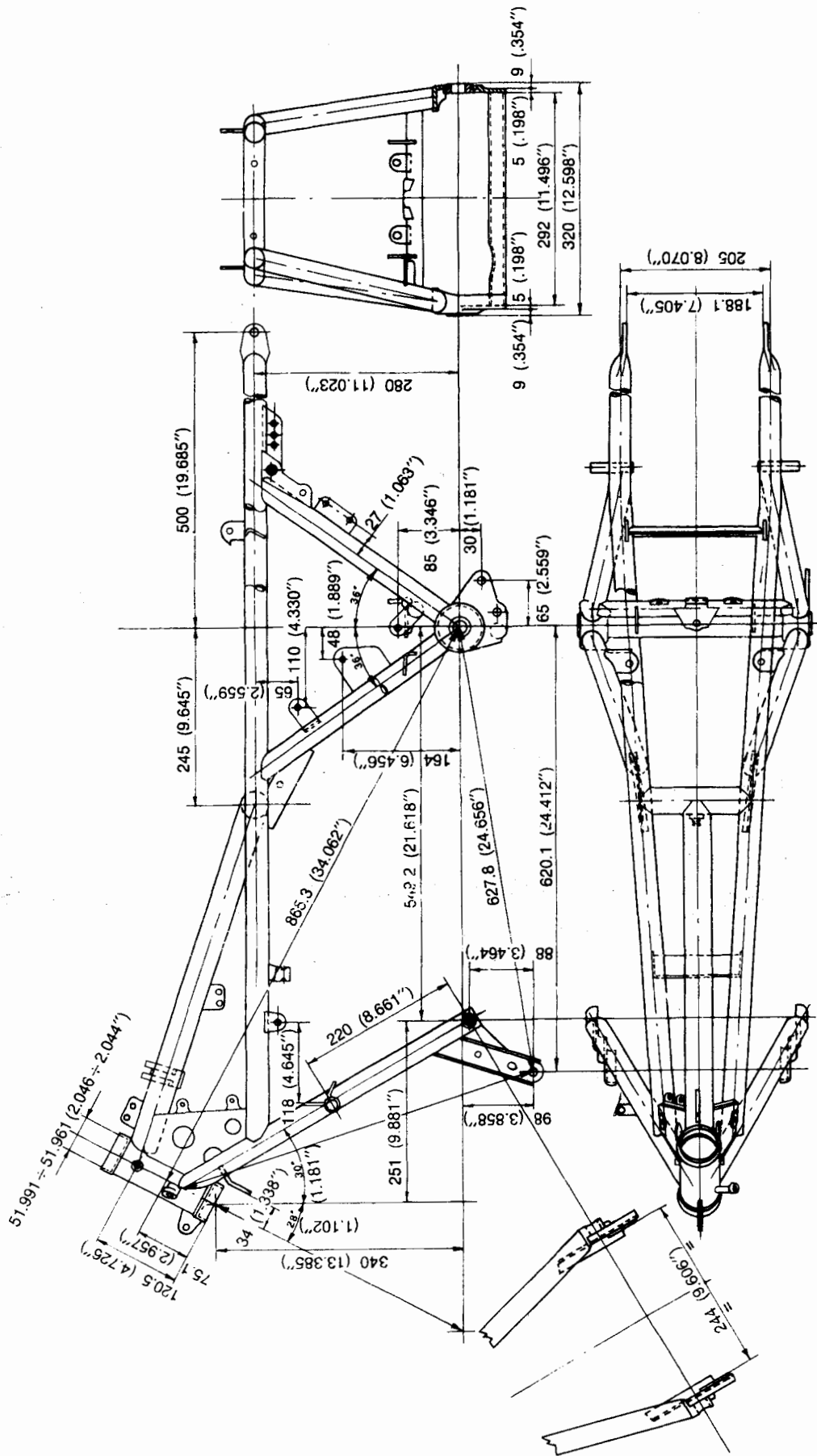

20 REAR SUSPENSION

The machine fits 2 rear shock absorbers with hydraulic dampers that can be adjusted to 3 different positions using the wrench supplied in the tool kit. In case of improper damper operation, they should be returned to the manufacturers for overhauling (see drawing fig. 136 «V1000 G5» and fig. 138 «1000 SP»).

Spring features - V 1000 G 5 (fig. 137)

Free length: 293 mm (11.53").

Length under 108 kg load (238 lbs) should be 212 mm (8.34").

Length under 130 kg (286 lbs) should be 199.5 mm (7.89").

Length under a load of 232 kg (510 lbs) should be 138 mm (5.43").

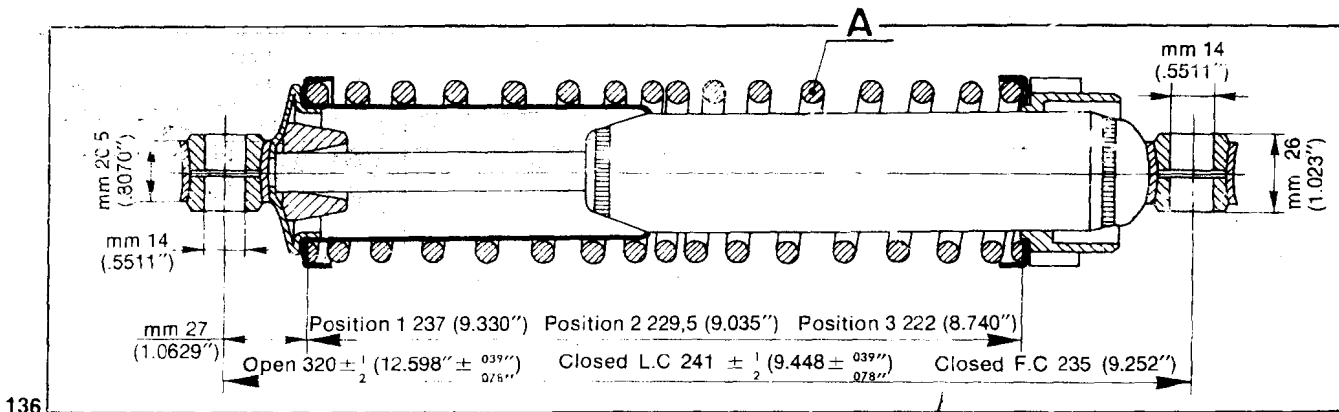

136

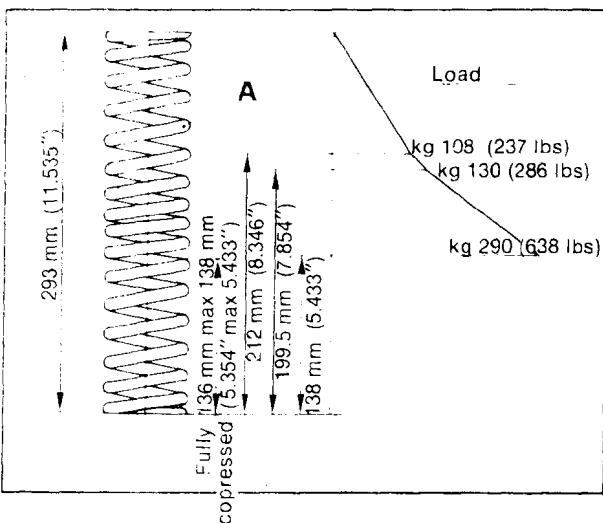

137

1000 SP (fig. 138/1)

Free length: 280 mm (11.023").
 Length under a load of 52 kg (114 lbs) should be 237 mm (9.33").
 Length under a load of 103 kg (226 lbs) should be 197 mm (7.75").
 Length under a load of 145 kg (320 lbs) should be 168 mm (6.61").
 Length under a load of 232 kg (510 lbs) should be 135 mm (5.31").

If any spring has deformed or is not within the above limits, replace.

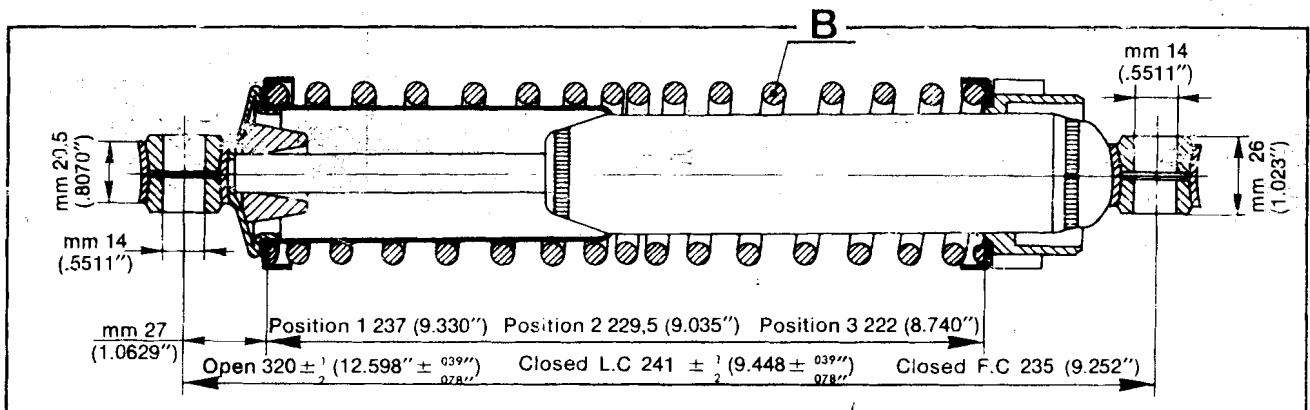

138

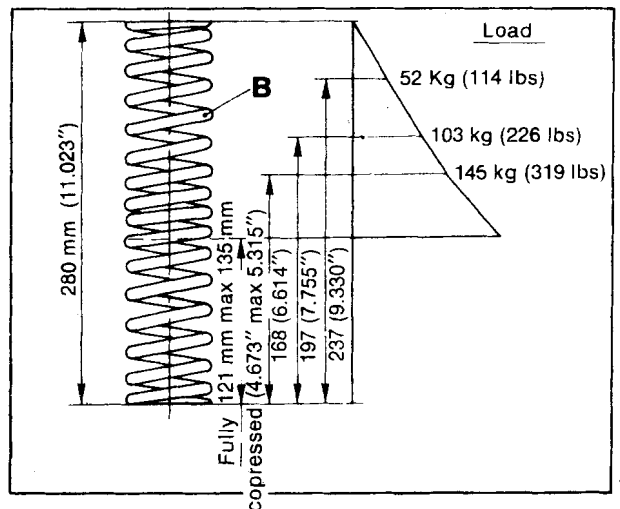

138/1

21 FRONT SUSPENSION AND STEERING

FRONT FORK

Removal from machine (fig. 139)

After removing the front wheel as described in para 23.1, remove the fork as follows:

- Remove windshield.
- Unhook all electrical connections (headlight and turn signal indicators).
- Remove screws «A» and disconnect hydraulic caliper «B» from the fork covers.
- Undo screws «M», remove clips «N», and refit screws «M».
- Undo screw and washer «P» disconnect steering damper «L» from bottom yoke «Q».
- Undo bolts «C» and remove the headlight from the fork lugs.
- Undo pinch bolt «D» retaining handlebar «O» and tilt the handlebar complete with instruments and controls over the fuel tank.
- Undo nut «E» and steering unit securing bolts «F» and «G».
- Undo nut «H» and take out bearing cover «I», when the fork complete with steering tube can be lifted up (make sure not to drop the bottom fork covers).

Dismantling the fork cover with rod and damper from the fork legs (fig. 140)

After removing the front wheel from the fork legs, front fender, headlight, and calipers, proceed as follows:

- Undo top screws «A» securing the cover assembly to fork tubes «B».
- / Move housings «C» upwards.
- Slide out the fork legs «D» complete with dampers from fork rods «B».

Removing the fork inner tubes (fig. 141)

After removing the front wheel, front fender, headlight, bottom fork covers with dampers, take away:

- Allen screws securing the fork legs to the top linking plate «A».
- Allen screws securing the fork legs to bottom yoke «B» and slip out both fork tubes «C» (See arrow «D»).

Front fork components (fig. 142)

- 1 Screw, front fork tube securing.
- 2 Washers.
- 3 Spacer.
- 4 Screw, damper.
- 5 Screw.
- 6 Washer

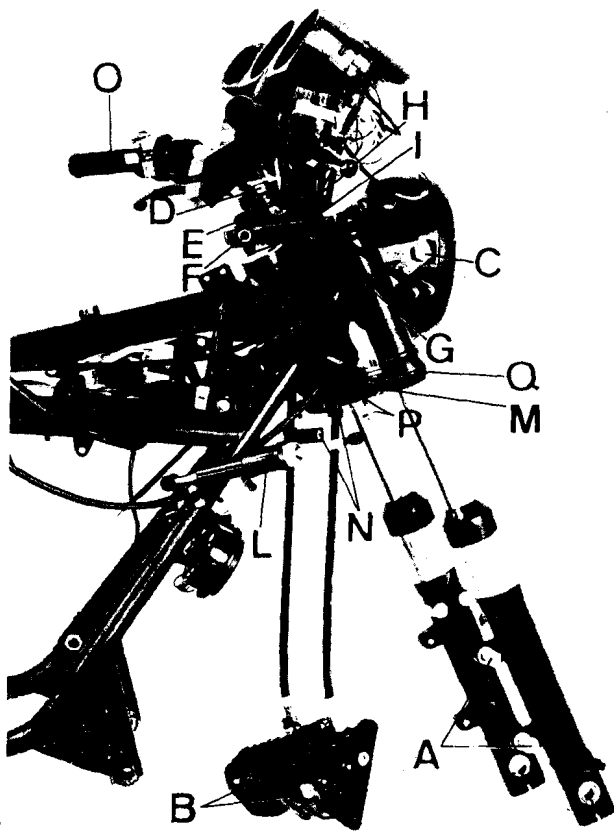

139

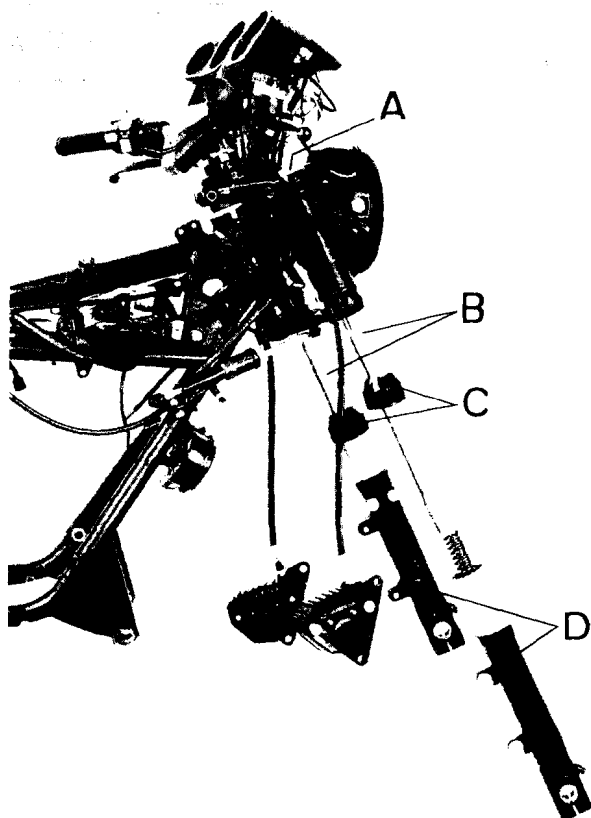

140

- 7 Fork sleeve.
- 8 Screw, spindle securing.
- 9 Nut, spindle screw.
- 10 Oil drain screw from fork legs.
- 11 Washer, oil drain screw.
- 12 Studs, fender securing.
- 13 Dust caps.
- 14 Seal rings.
- 15 Bottom caps.
- 16 Circlips.
- 17 Rod ends.
- 18 Tubes.
- 19 Damper nuts.
- 20 Nylon caps, spring return.
- 21 Dampers.
- 22 Upper fork caps.
- 23 Gaskets, upper caps.
- 24 Bearings, cover retaining.
- 25 Stay tubes.
- 26 Springs, lower.
- 27 Spacers.
- 28 Top springs.
- 29 Fork sleeves.
- 30 Bottom yoke.

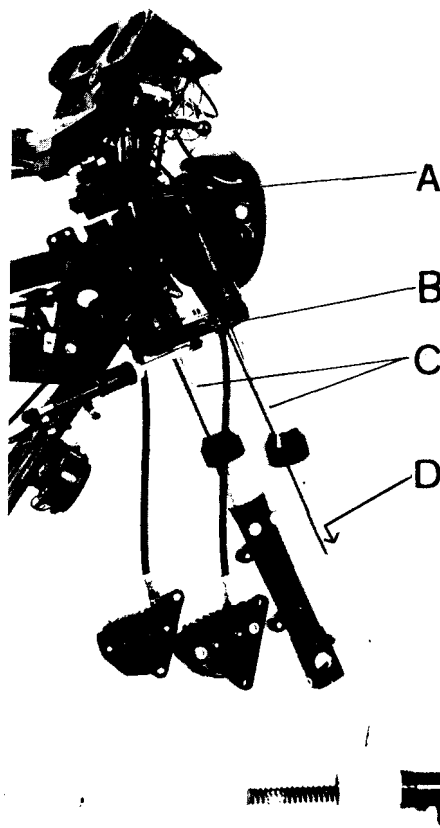

141

Inspections

Ensure that the chromed section of the fork rod which slides in the bottom cover is in good condition and free from scorings. Ensure also the rod is perfectly straight and the threaded section undamaged.

Rod diameter (chromed portion): 34.715-34.690 mm (1.3662-1.365"). The bottom fork cover is in light alloy. Ensure its inner part is not scored or excessively worn.

I.D of cover is 34.750-34.790 mm (1.367-1.369").

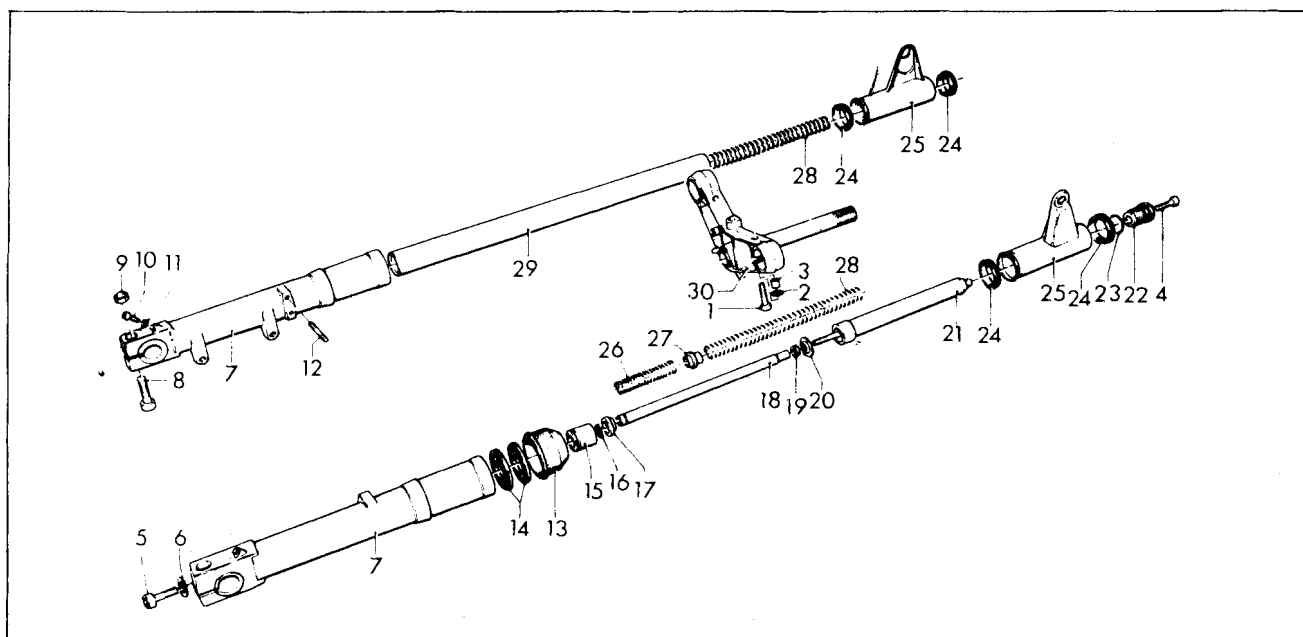

142

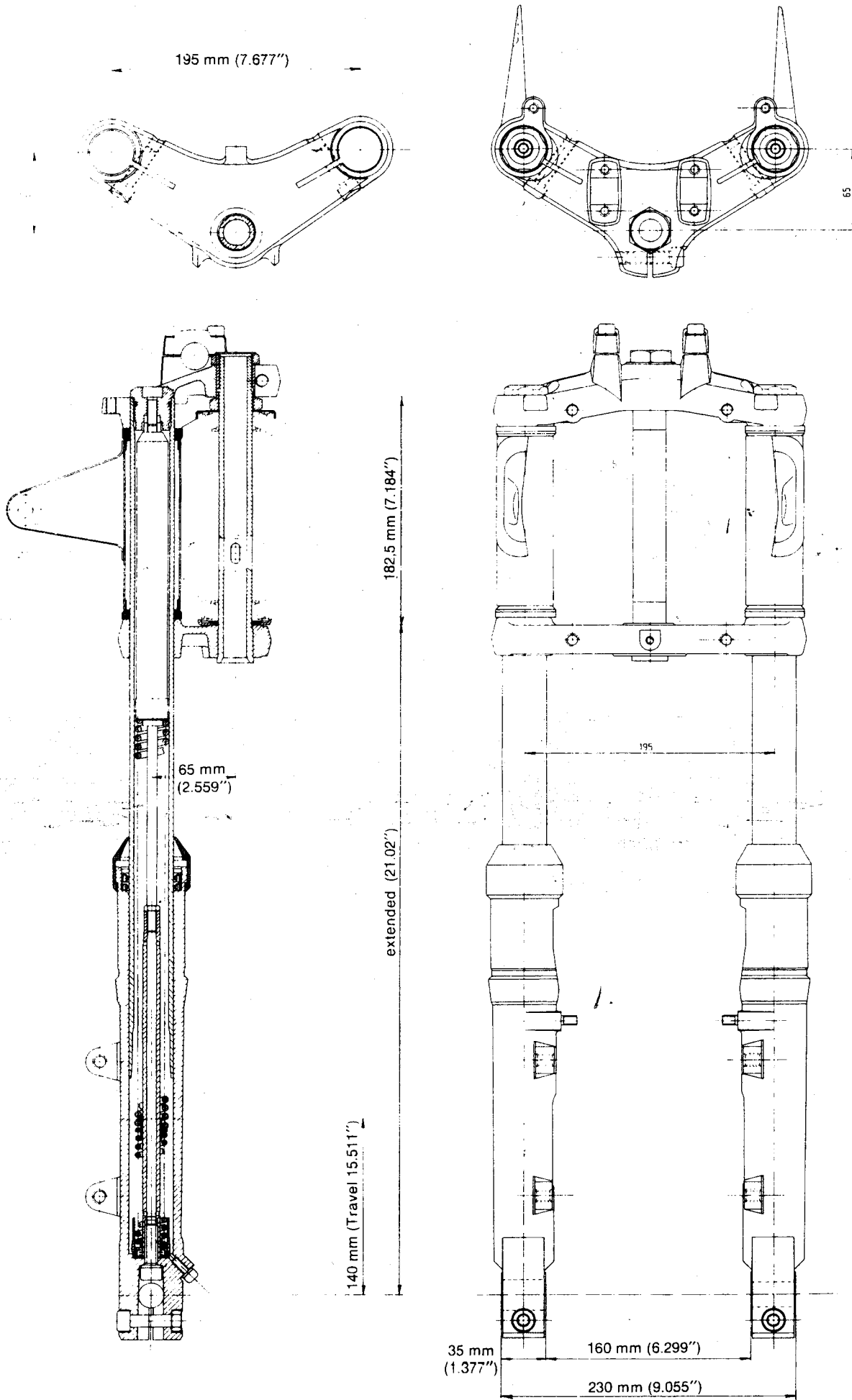

143
V 1000 G5

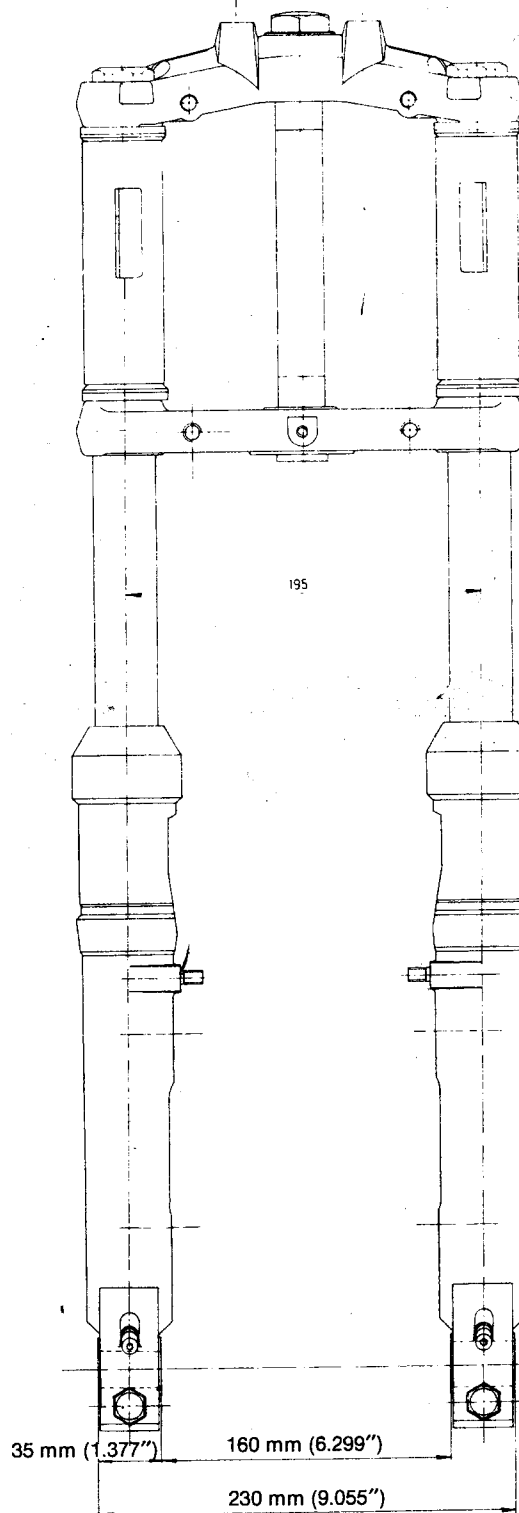
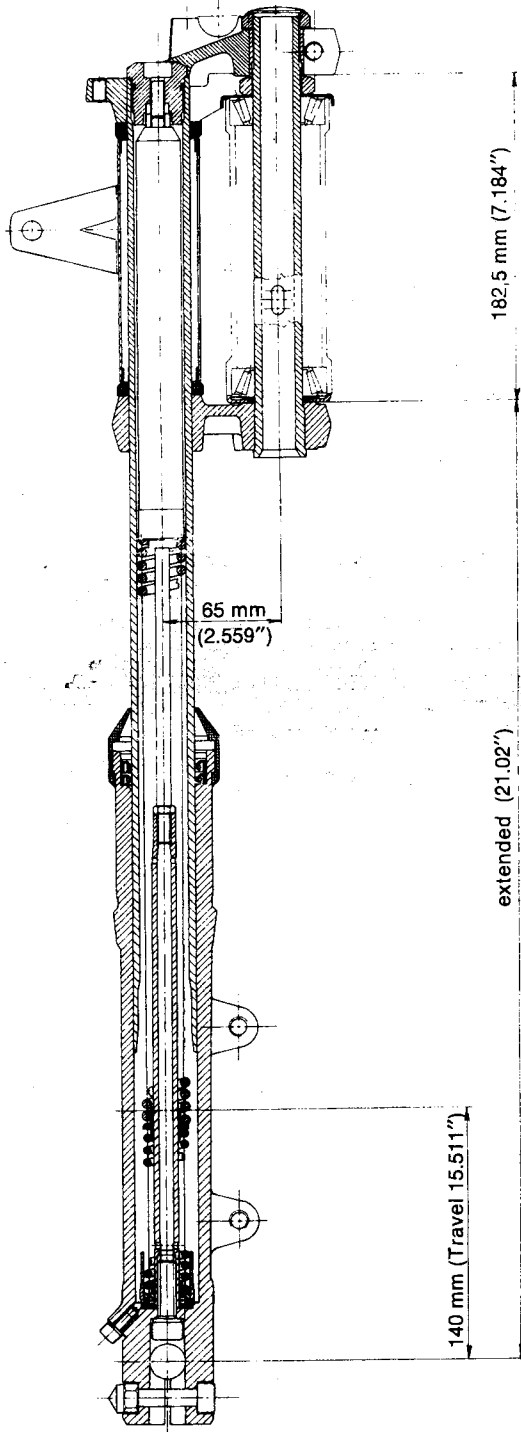
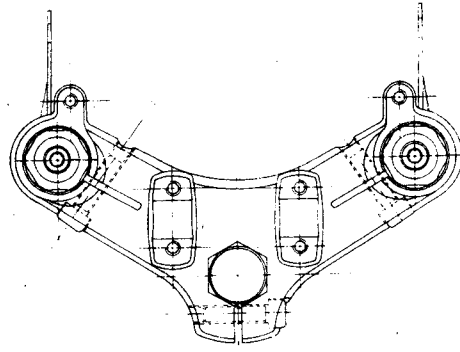
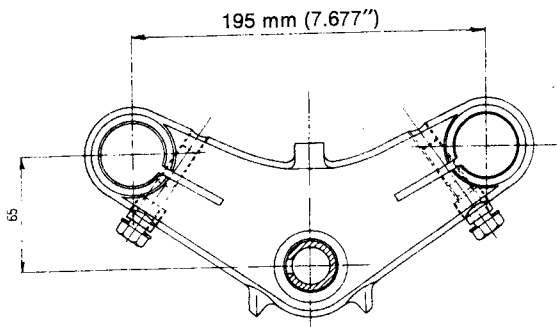

Original rod-cover clearance

0.045-0.100 mm (.00177-.0039").

Make sure the short spring in the fork has following sizes and loadings (fig. 145):

- A Free length 95 ± 1.5 mm ($3.74 \pm .0059$ ").
- B When compressed to 91.5 mm (3.60") should give a load of $9.3 \text{ kg} \pm 3\%$ (20 lbs).
- C When compressed to 60.9 mm (2.39") should give a load of $90.7 \pm 3\%$ (199 lbs).

Fork long spring (fig. 146)

- A Free length 336 ± 1.5 ($13.22 \pm .0059$ ").
- B When compressed to 328 mm (12.91") should give a load of $9.3 \text{ kg} \pm 3\%$ (20 lbs $\pm 3\%$).

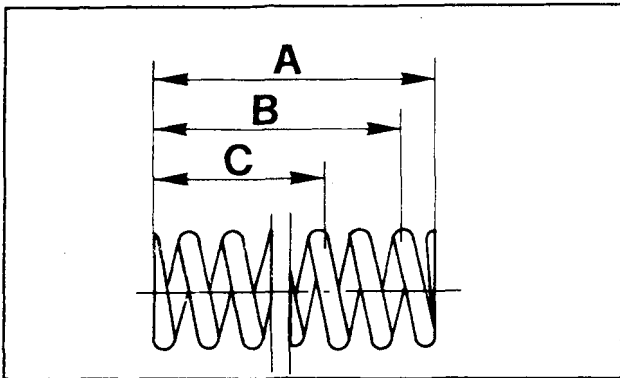

145

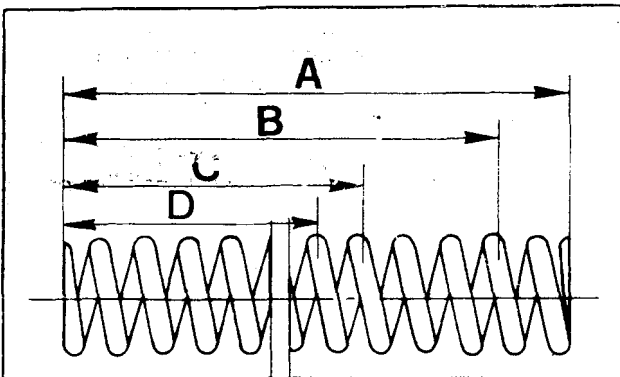

146

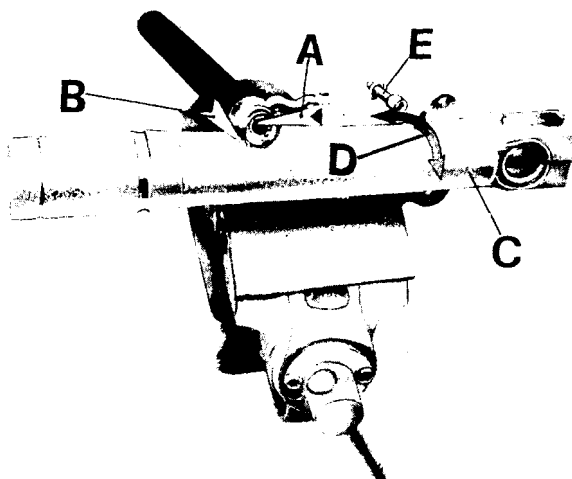

147

C When compressed to 257 mm (10.11") should give a load of $90.7 \text{ kg} \pm 3\%$ (199 lbs).

D When compressed to 219 mm (8.62") should give a load of $134 \text{ kg} \pm 3\%$ (293 lbs).

- After an accident make sure the fork is not bent. See sizes in drawing fig. 143.
- Ensure the dust guard on the fork covers are not cracked
- Check if the circlip is still efficient.
- Ensure the seals on the bottom covers are not crumbled or excessively hardened.
- Check if the plastic ring on the damper rod is crushed or crumbled.
- Check if both dampers are equally loaded. If not, replace them.
- Check if the threaded portion of the fork tube and bottom yoke is stripped. If so, replace.
- Ensure the steering bearings are still in good state. If not, replace.

Re-assembling the dampers with rods and springs the fork covers (fig. 147)

- Ensure that the two slots on the inner pawls are a proper fit (on bush «A») and that the outer pawl «B» of this bushing is a proper fit into the inner slot of leg cover «C».

To ensure if they are properly inserted (after fitting the damper assembly on the cover «C»), it is necessary to gently turn the leg cover to the right or left (see arrow «D») until the pawls are heard to click home. At this stage, screw in aluminium screw and washer «E» on the bottom end of the cover to secure the damper rod-spring-nut assembly on the cover itself.

Re-assembling the fork and refitting it on the steering column

Reverse the dismantling sequence bearing in mind to finally fill up the legs with oil.

Quantity required for each leg: 0.080 lts (2 oz) for V 1000 G5 and 0.090 (3 oz) for 1000 SP of AGIP F 1 fluid ATF Dexron or equivalent.

Variables for 1000 SP

Controls:

- Ensure the long spring (fig. 146) has the following features:

- A Free length 336 ± 1.5 (13.22 ").
 - B When compressed to 327.5 mm (12.893"). Should give a load of $8 \text{ kg} \pm 3\%$ (16.3 lbs).
 - C When compressed to 239 mm (9.40") should give a load of $90.7 \text{ kg} \pm 3\%$ (199.993 lbs).
 - D When compressed to 219 mm (8.62") should give a load of $109.5 \pm 3\%$ kg. (231 lbs).
- Check fork sizes against drawing fig. 144.
Ensure the voltmeter and clock are in good conditions.

Assembly

Reverse the dismantling operations.

22 SWINGING ARM

22.1 INSPECTION

Ensure the rear swing arm has no abnormal bendings or defective welding. Check condition of the bearing housings and smoothness of the union faces to the drive box.

Check sizes drawing fig. 148.

22.2 REMOVING THE BEARINGS FROM THE SWINGS FORK

Use puller N. 18 92 72 50 (55 in fig. 149) to remove the cardan joint bearing (to take out the fork spindle bearings use puller 12 90 47 00) (14 in fig. 150).

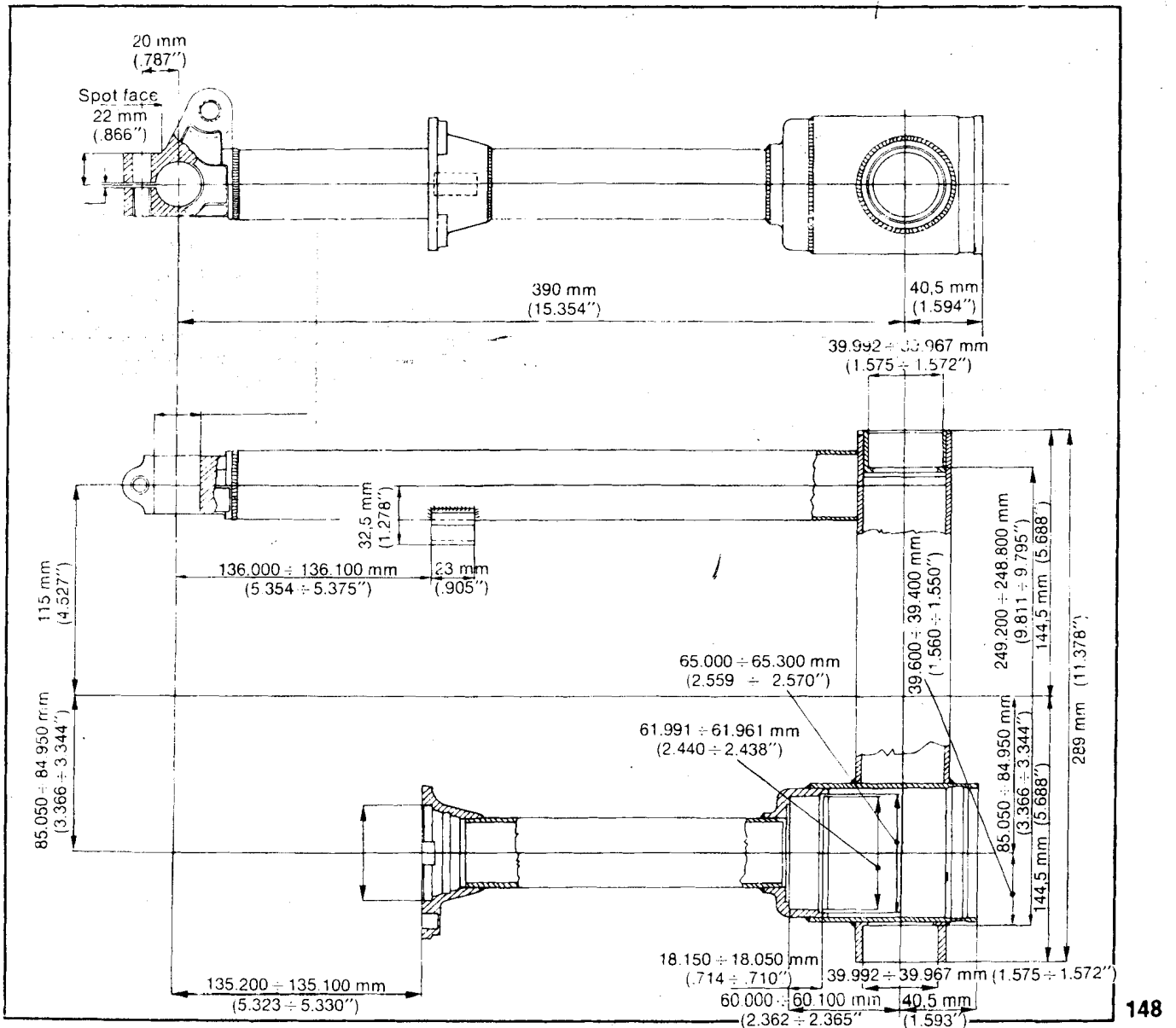

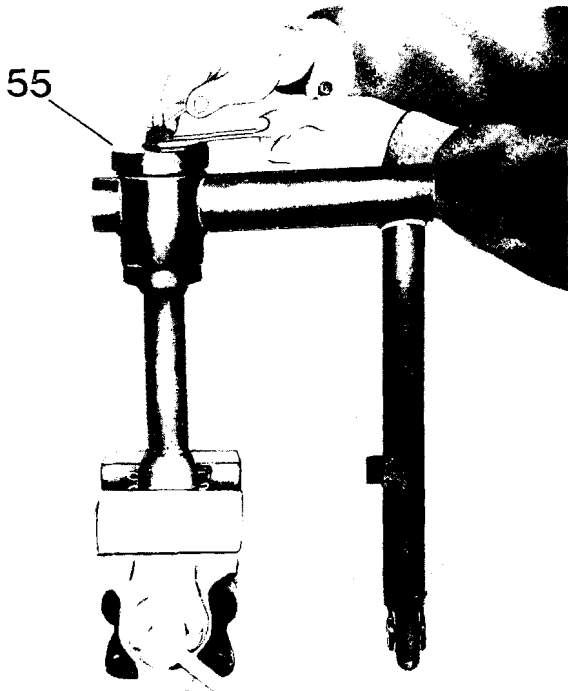

22.3 PRESSING THE OUTER RACES ON THE SWING ARM TAPER BEARINGS

Press these in by the aid of punch N. 17 94 52 60 (33 in fig. 151).

22.4 PRESSING THE BEARINGS INTO THE R/H ARM OF THE SWING FORK

Press this bearing in using punch 17 94 53 60 (31 in fig. 152).

22.5 ADJUSTING THE SWING ARM PLAY (fig. 153)

Ensure the swing fork oscillates freely without any play.
Be sure both spindles project by the same amount.
This adjustment is best done using a screwdriver «A» and gauge «B».

149

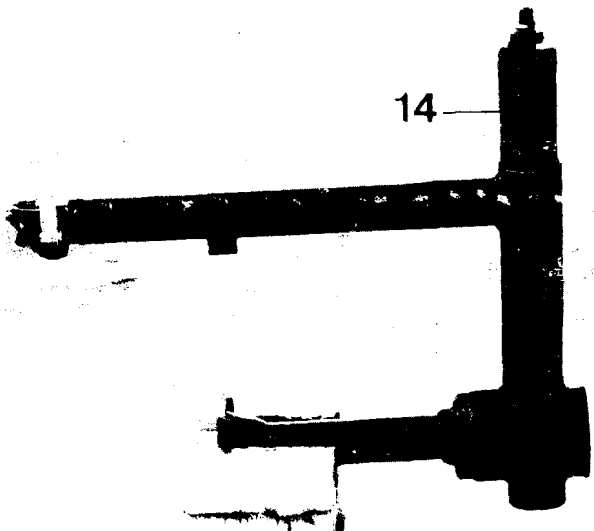

150

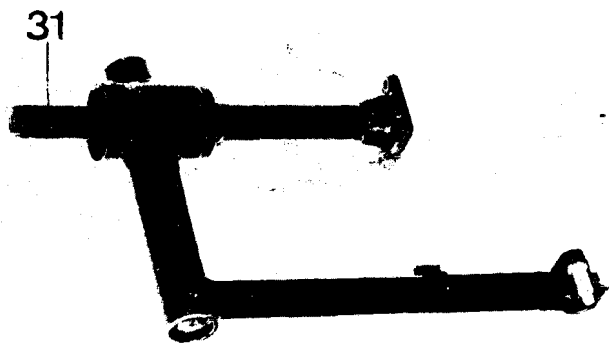

152

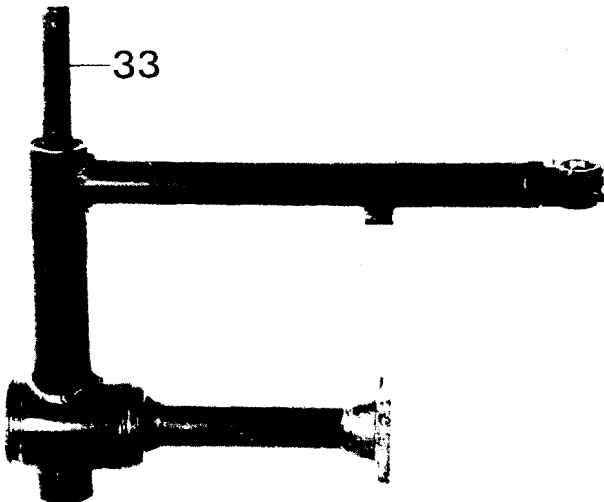

151

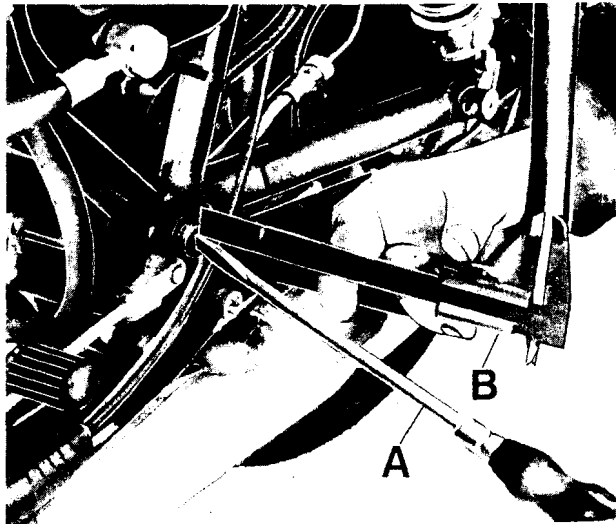

153

23 WHEELS

23.1 REMOVING THE FRONT WHEEL - V 1000 G 5 (fig 154)

- Fit stand part N. 18 91 24 50 (1 in fig. 35) under the engine.
- Undo bolts «F» and «G» that secure caliper «A» to the L/H leg cover and by lightly raising the caliper withdraw it from the brake disc.
- Undo spindle nut «B» on the R/H side.
- Loosen the spindle-leg cover securing screw «C».
- Take out spindle «D».
- Take of the brake disc from the caliper bolted on the R/H fork leg.

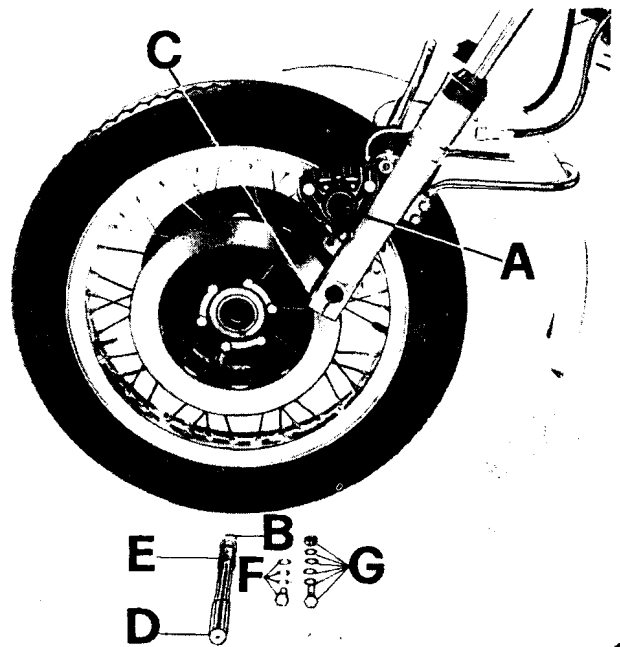

Removing the front wheel hub (fig. 155)

Operate as follows:

Undo nuts «1» on the braking disc securing screws to hub «3», and take out screws «2» and spacer «7». Remove both brake disc spacing flanges «4» and from these remove bearings «5», circlip, «6» and finally bearing spacer «8».

Inspection

After stripping the hub, check the brake discs for scoring, also that the flange joining face is not damaged and the circlip still efficient. Replace, as necessary.

Re-assembling the front wheel hub

Reverse the dismantling sequence except that it is necessary to check wobbling of the disc with a proper gauge.
Maximum wobble: 0.2 mm (.0078").

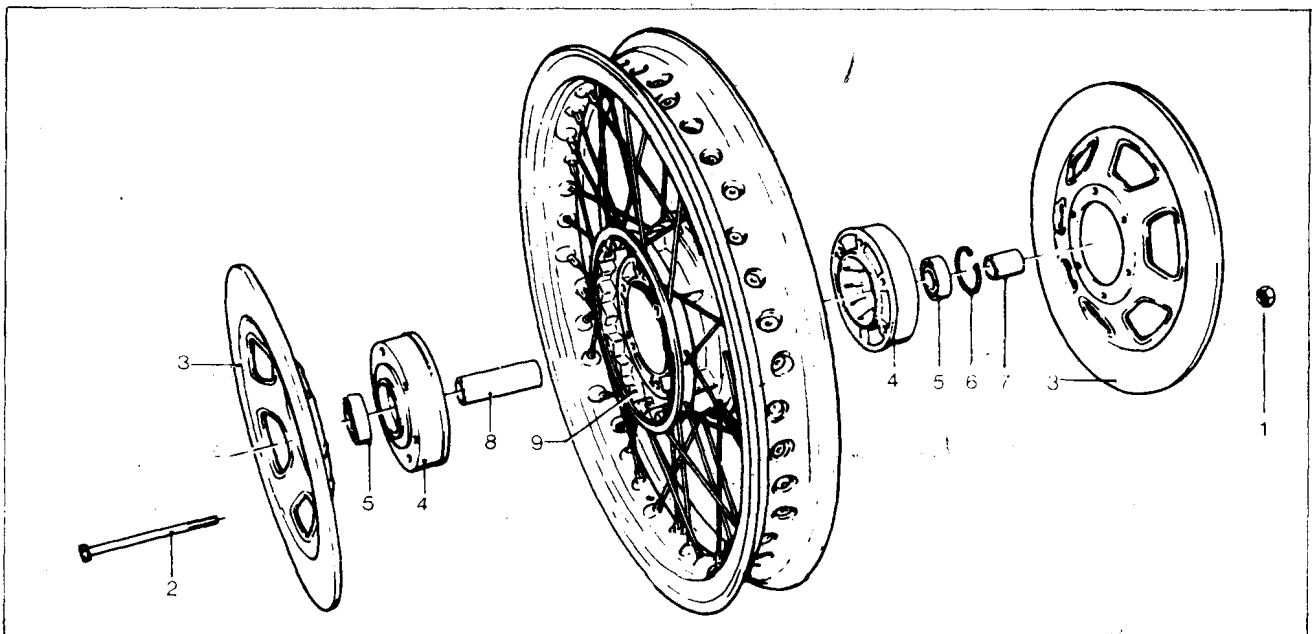

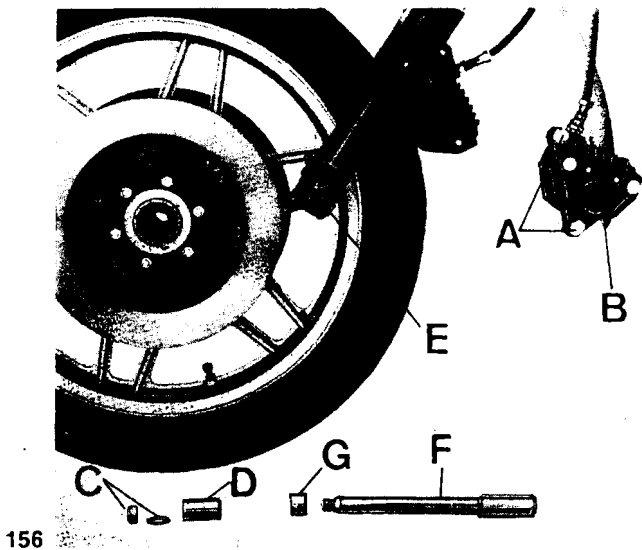

156

Tighten the brake disc nuts to hub with a torque wrench set to 2.2-2.4 kgm (16-18 ft. lbs). Ensure all spokes are properly tensioned and the wheel is well balanced.

Assembling the front wheel on the front fork legs

Reverse the removal sequence. The spindle nut has to be tightened to a torque loading of 14-15 kg (100-108 ft/lbs). Spacer «E» has to be fitted on the R/H side (fig. 154).

23.2 FRONT WHEEL - 1000 SP

Removal from front fork legs (fig. 156)

- Fit stand N. 18 91 24 50 (1 in fig. 35) under the engine.
- Loosen screws «A» securing the hydraulic caliper «B» to the fork leg, raise the caliper with piping and pull it out from the disc.
- Undo nut and washer «C» on the wheel spindle and remove spacer «D».
- Loosen screws «E» securing the spindle to fork rods «E».
- Slide out spindle «F» with spacer «G» (from the L/H side).
- Remove brake disc from the caliper on the bottom R/H fork sleeve.

Removing the front wheel hub (fig. 157)

- Undo six self-locking nuts «1» and remove six screws «2». Remove both brake discs «3».
- Using a suitable punch, remove both bearings «4» with spacer «5».

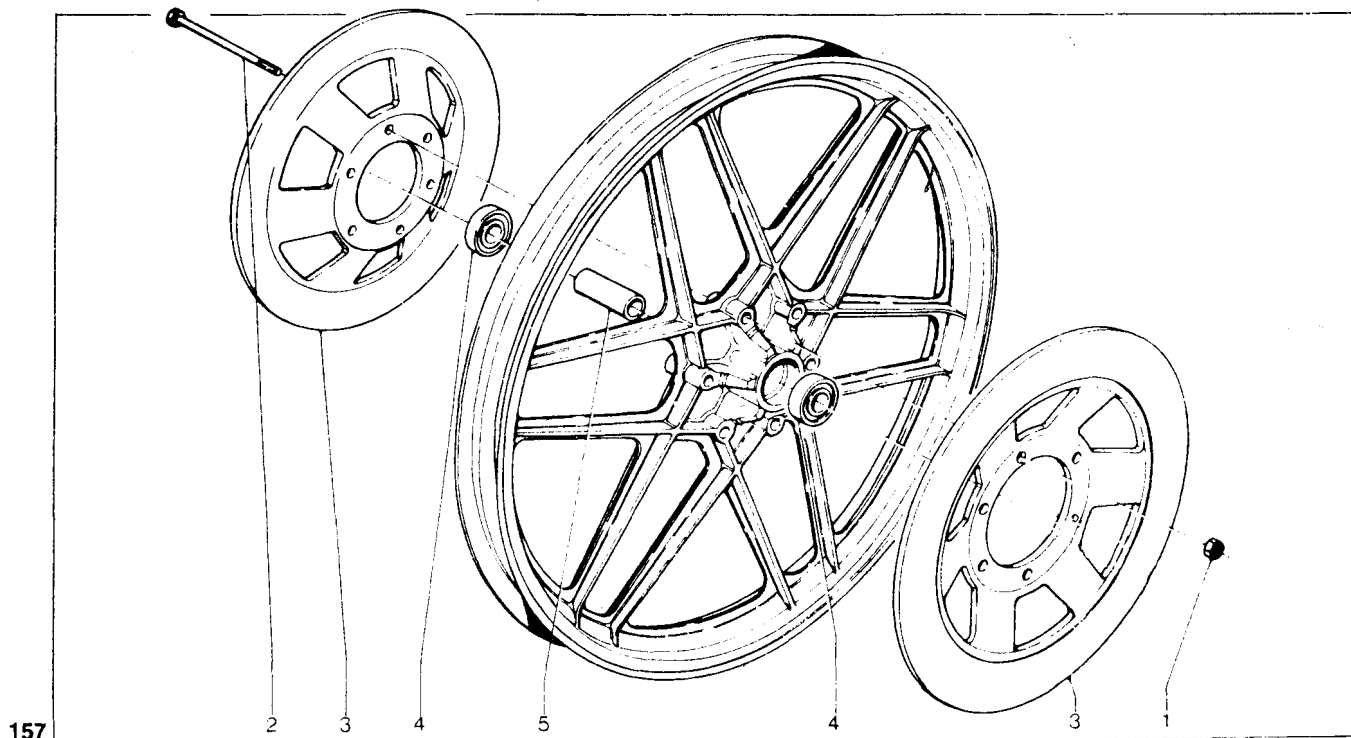

157

Inspection

After completely stripping the hub, check for any brake disc scoring and if the hub portion contacting the discs is not damaged.

Check also condition of the wheel bearings and if any part is not perfectly efficient, replace it.

Be sure the wheel is quite true and there are no axial clearances or wobbblings (see fig. 158).

Re-assembling the wheel hub

Reverse the dismantling sequence, ensuring there is no disc floating, checking this with a gauge.

Maximum allowed wobbling: 0.2 mm (.0078").

Tighten the securing screw nuts with a torque wrench set to 2.2-2.4 kgm (16-18 ft./lbs).

Re-assembling the wheel on the fork legs

Reverse the dismantling operations. Ensure spacer «D» on spindle «F» is fitted on the R/H side and spacer «G» on the left (fig. 156).

The spindle nut is tightened to 14-15 kgm (100-108 ft./lbs) with a torque wrench.

23.3 REAR WHEEL - V 1000 G 5

Removing the rear wheel from the swing fork arm and rear drive box (fig. 159)

Proceed as follows:

- Undo the bolt securing the L/H muffler to the frame, remove clip and the muffler from the exhaust pipe.
- Undo nut «B» on the spindle drive box side.
- Loosen spindle securing bolt «C» to swing fork arm.
- Remove spindle «D» from rear drive box, hub and swing fork arm.
- Remove brake disc from caliper «E».
- Slip off plate and caliper complete with piping and secure it to the frame tube.
- Lean the machine to the right just sufficiently to allow wheel «F» to drop out.

Stripping the rear wheel hub (fig. 160)

Remove screw «1», washer «2», and lockplate «3». Remove circlip «4», cush drive plate «5» and rubber blocks «6».

Undo nuts «7» and remove screws «8».

Withdraw brake disc «9».

Remove seal «10», flange «11», and from this, seal «12», bearing «13» and from the other side bearing «13», washer «14», gasket «15», and finally spacer «16».

Inspection

- Ensure the cush plate retaining circlip has not lost its elasticity.

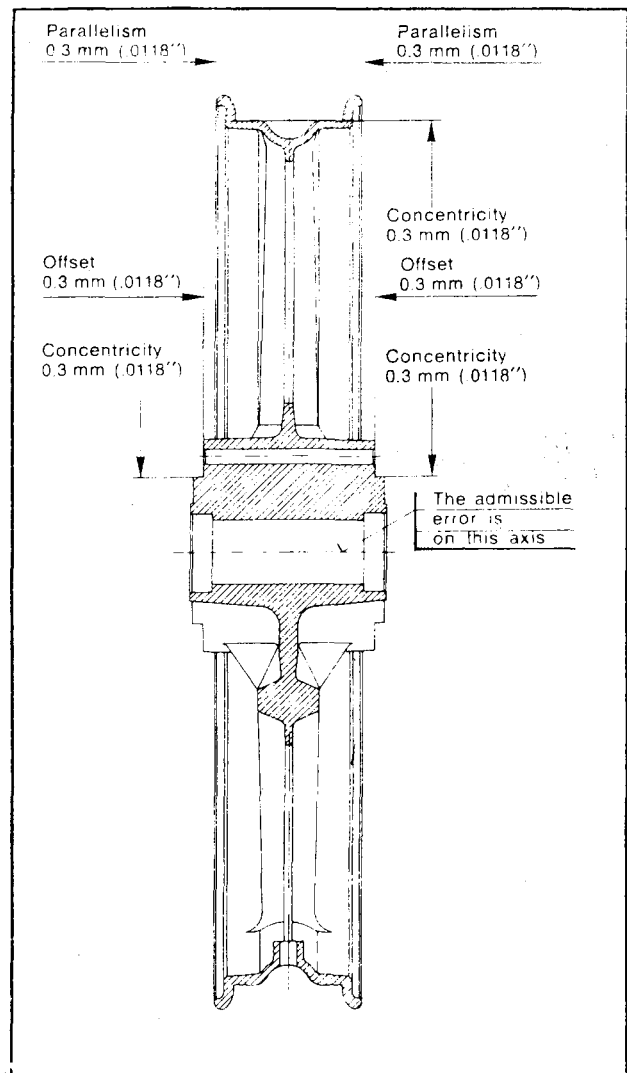

158

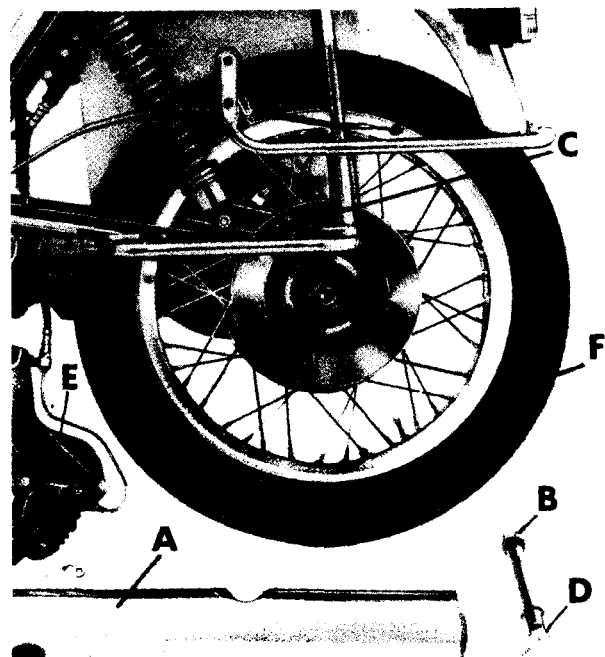

159

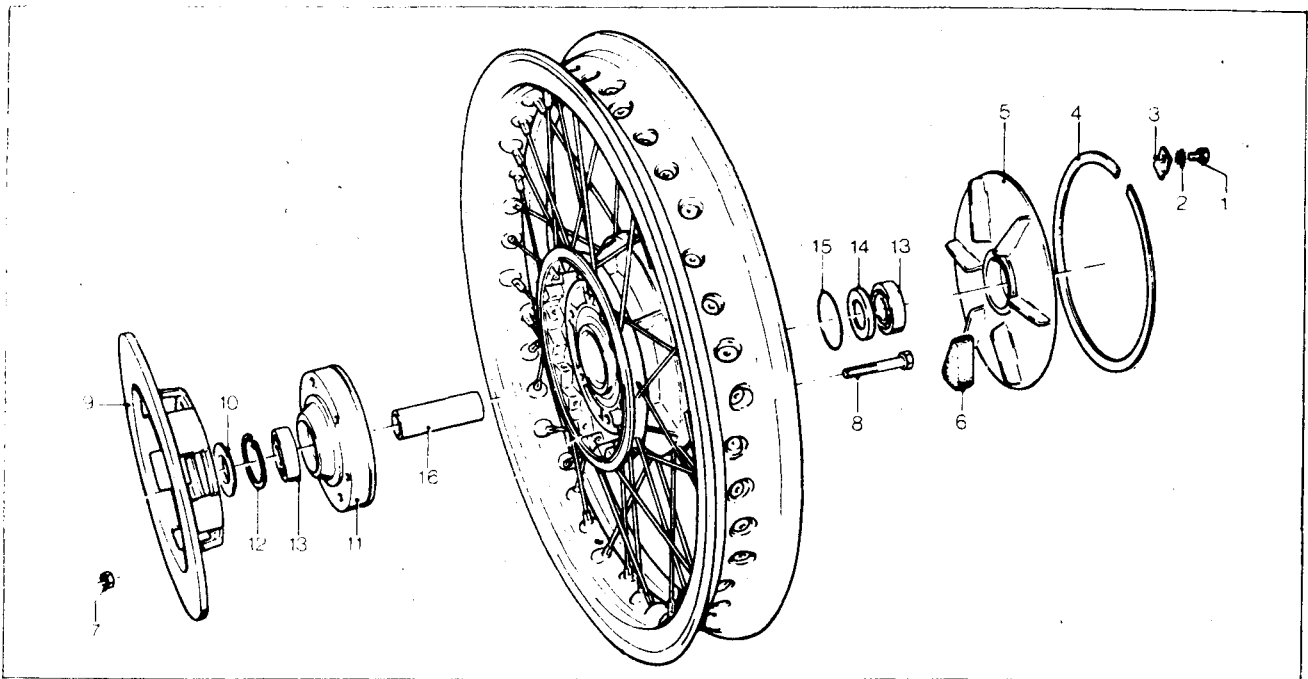

- Ensure the cush drive plate is undamaged.
- Ensure the cush drive rubber blocks have not hardened or crumbled.
- Check for any scoring of the brake disc.
- Ensure the bearing-flange circlip is still efficient.
- Check condition of the bearings.
- Ensure all spokes are properly tensioned and the wheel is true.

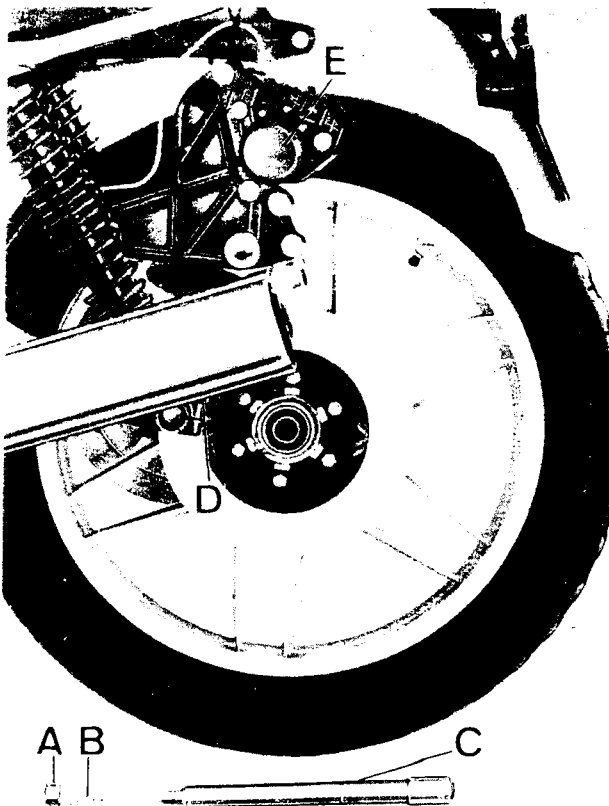

Re-fitting the rear wheel on the swing arm and drive box

Reverse the dismantling sequence ensuring caliper plate «E» (fig. 159) is inserted in the swing arm lug.

23.4 REAR WHEEL - 1000 SP

Removal (fig. 161)

Proceed as follows:

- Set the vehicle up on the center stand.
- Loosen spindle securing nut «A» with washer «B» from spindle «C»; drive box side.
- Loosen screw «D» securing spindle «C» to the swing fork arm.
- Withdraw spindle «C» from drive box, wheel hub, and the swing arm.
- Withdraw plate «E» complete with hydraulic caliper and tubing, securing it to the frame tube.
- Lean the machine to the right just sufficiently to allow the wheel to drop off the swing arm and drive box.

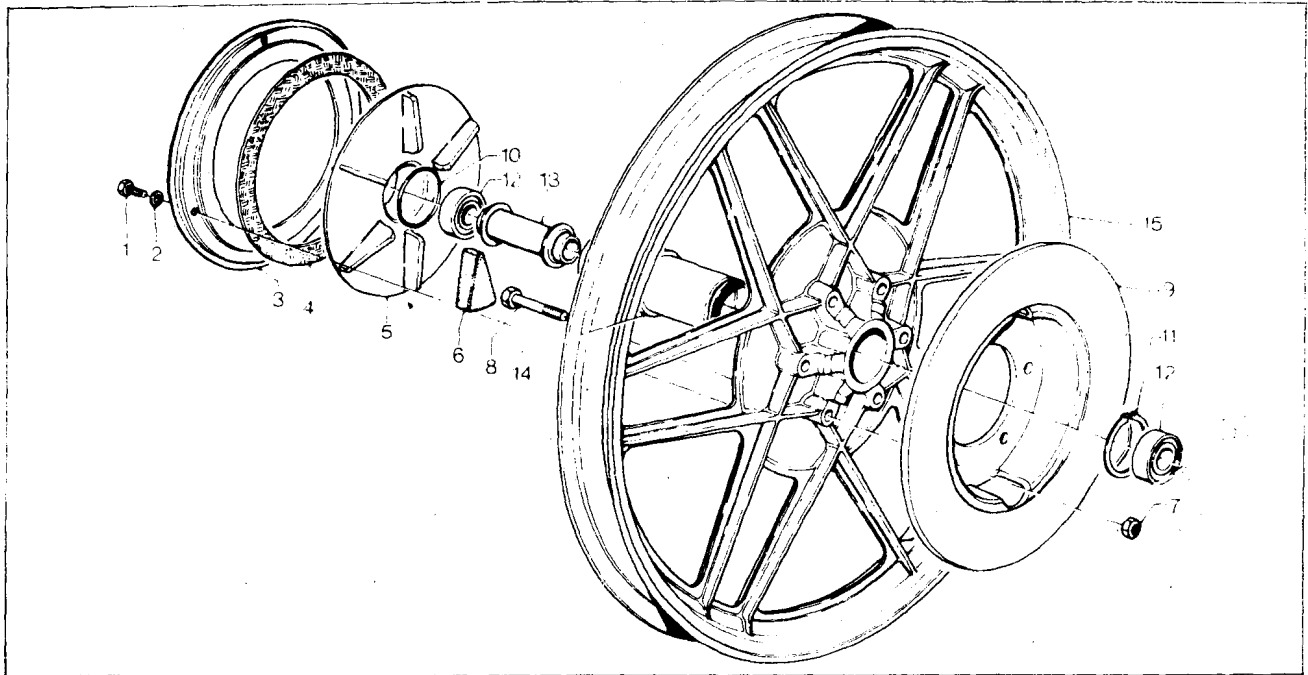

162

Stripping the rear wheel hub (fig. 162)

Operate as follows:

- Undo screw «1» with spring washer «2», remove flange «3», and friction ring «4».
- Remove cush drive plate «5» and the 12 rubber blocks.
- Undo self locking nuts «7» and remove spindles «8».
- Remove brake disc «9».
- Remove gasket «10», and L/H circlip «11».
- Remove both bearings «12» and spacer «13».
- Take off hub «14» from wheel «15».

Inspection

After all parts have been removed from the hub, check that:

- the cush drive blocks are not crumbled or hardened;
- the bearing plate is undamaged;
- the flange is not deformed;
- the gasket is still in good condition;
- Circlip and bearing are undamaged;
- Brake disc is not scored and the flat surface contacting the disc is undamaged.
- Finally check end play and floatings against drawing fig. 163 and balancing of the wheel (para 23.7).

Re-fitting the rear wheel

Reverse the removal sequence ensuring the plate carrying caliper «E» (fig. 161) is inserted in the lug on the L/H swing fork arm.

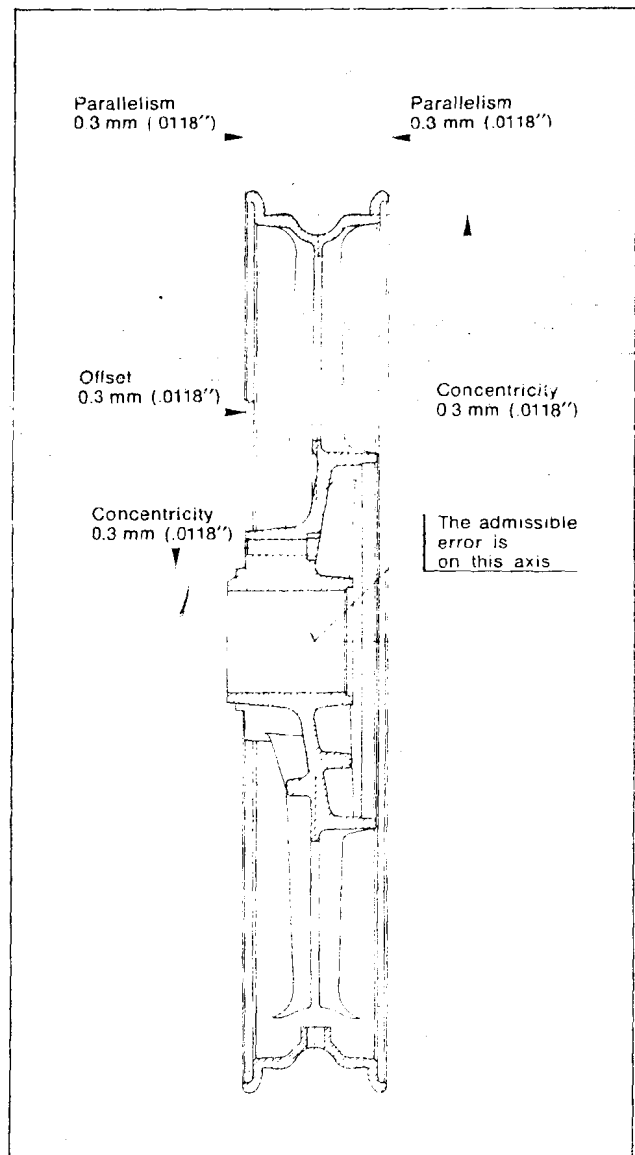

163

23.5 TIRES

The tire condition is of main importance as the stability, riding comfort, and even the rider's safety are largely dependent on the state of the tires.

Never use tires with tread less than 2 mm (.078").

An incorrect tire pressure can also affect stability and cause rapid deterioration of the tire itself.

Correct pressures are:

Front wheel

One or two persons: 2.1 kg/cm² (30 p.s.i.).

Rear wheel: - 1 person 2.4 kg/cm² (34 p.s.i.).

2 persons 2.6 kg/cm² (37 p.s.i.).

These data are intended for normal use (touring). In case of high way or constant high speed riding, increase tire pressure 0.2 kg/cm² (2.8 p.s.i.).

23.6 TENSIONING THE WHEEL SPOKES - V 1000 G 5

Make sure all spokes are properly tight and the wheel perfectly true.

- Turn the wheel by hand checking with a siip gauge for any offsets. If necessary tighten the left or right spokes until the wheel turns freely without any wobbling. This check should be made after the first 500 km (300 miles) and then every 1500 km (900 miles).

23.7 WHEEL BALANCING

To improve stability and decrease vibrations at high speeds, the wheels have to be properly balanced. A good wheel balancing is obtained as follows:

- remove the wheel and set it up on a forked stand;
- spin the wheel lightly several times and watch if it stops always in different positions. If so, the wheel is perfectly balanced;
- if one point of the wheel always stops at the bottom, put a suitable weight on the other side;
- repeat the operation until the wheel is correctly balanced.

This check should be done after the first 500 km and then every 1500 km (900 miles).

23.8 TIRE REMOVAL AND REFITTING - V 1000 G 5

If the tires have an arrow on their sides, fit them as follows:

- the rear wheel with the arrow turned towards the riding direction;
- the front wheel, with the arrow turned against the riding direction.

23.9 TIRE REMOVAL AND REFITTING - 1000 SP

This model fits light alloy rims which offer higher mechanical resistance but may suffer damage from

a functional and aesthetical aspect if improper toolings is used for the removal and refitting operations. Under the circumstances, never use tools that have ribbings or sharp edges on the side contacting the rim.

The contacting surface of such tooling has to be very wide, smooth, and with rounded edges. The use of one of the lubricants available on the market for this purpose will greatly facilitate tire sliding and setting on the rim, preventing also overloads on the tools.

It is also very important for the tire beads to be properly entered into the center rim groove.

If the tires have an arrow on their sides, fit them as follows:

- the rear wheel with the arrow turned towards the riding direction;
- the front wheel, with the arrow turned against the riding direction.

23.10 CHECKING AND OVERHAULING THE BRAKING CIRCUITS - RIGHT FRONT, LEFT FRONT, AND REAR BRAKES (fig. 164 and 165/1)

1 MAINTENANCE

For a good working of the brakes, the following instructions should be strictly followed:

- Periodically check the fluid level in the reservoir for the front and rear master cylinders: it should never fall below the partition in the reservoir.
- Periodically or whenever necessary top up the fluid in the reservoirs (every 5000 km = 3000 miles or so). For topping up use only fresh fluid taken from sealed containers to be opened just before use.
- Every 15.000 km (9500 miles or so) or at least once a year, completely renew the oil in the brake circuits.

The fluid flexible pipes have to be always full and without air; a long and elastic movement of control levers «B» evidences the presence of air inside the pipes.

When cleaning the braking circuits use only fresh fluid. Never use alcohol to clean or compressed air to dry. Use: AGIP F. 1 Brake Fluid (SAE J 1703 B).

2 AIR BLEEDING FROM BRAKING CIRCUITS - V 1000 G 5 (fig. 165)

This operation is required when the movement of the control levers is long and elastic because of the presence of air inside the braking circuits.

To bleed the air, operate as follows:

Braking circuit for right front brake

- Turn the handlebar until fluid reservoir «A» reaches the horizontal position.
- Fill up reservoir, if necessary, taking care that during the bleeding operation the fluid does not go lower than the transparent section of it.
- Act on one caliper half «F» at the time as follows:
 - remove rubber covers and fit a transparent fle-

xible duct «G» of which the other end is plunged in transparent container «H» partially filled with fluid of the same type.

2 Loosen drain plug «E».

3 Completely operate control lever «B» on the handlebar several times: release it slowly and wait a few seconds before pulling it again. Repeat the operation until the pipe plunged into the transparent container «G» emits airless fluid.

4 Keep control lever «B» fully pulled and lock drain plug «E». Then remove plastic pipe «G» and remount the rubber cap on drain plug. If the bleeding operation has been correctly done, a direct and efficient working of the fluid will be immediately perceived after the initial idle movement of lever «B». If not, repeat the air bleeding operation.

Front left and rear braking circuit (fig. 166)

Carry out the same operations as indicated in «Checking the brake fluid level and changing the brake fluid in the reservoir» except point 1 and in «Braking circuit for the right front brake» except points «3» and «4» which are replaced as follows:

1 Fluid level in the reservoir is indicated by warning light «10» in fig. 4 located on the instrument panel. Fill up when this light comes on.

3 Completely operate pedal «B» etc.

4 Keep pedal «B» fully pressed down etc.

Checking the brake fluid level and changing the brake fluid in reservoir (fig. 165-166) - Model «V 1000 G 5»

For efficient brake operation, the following directions should be followed strictly:

1 Periodically check the fluid level in reservoir «A». It should never be below the transparent part of the reservoir partition.

2 Periodically, or whenever necessary, top up fluid reservoir «A» after loosening plug «D» and taking off the gaiter (fig. 165).

When the fluid falls under level in the reservoir for the front left and rear brakes, this is warned by an optical indicator on the panel «10» in fig. 10 connected to solenoid «C» (fig. 166).

To top up this reservoir it is necessary to undo plug «D» of master cylinder «A» (fig. 166), after disconnecting the electrical connections.

To top up use only fresh fluid taken from sealed containers to be opened just before use.

3 Completely renew the brake fluid every 15.000 km (9500 miles) or at least once a year. The flexible pipes should always be full and without air. A long and elastic movement of control levers «B» evidences the presence of air inside the pipes. When cleaning the braking circuits use only fresh fluid.

Never use alcohol to clean or compressed air to dry. Metal parts are best cleaned with Trichloroethylene. Fluid to be used: AGIP F.1. Brake fluid - SAE J 1703 B.

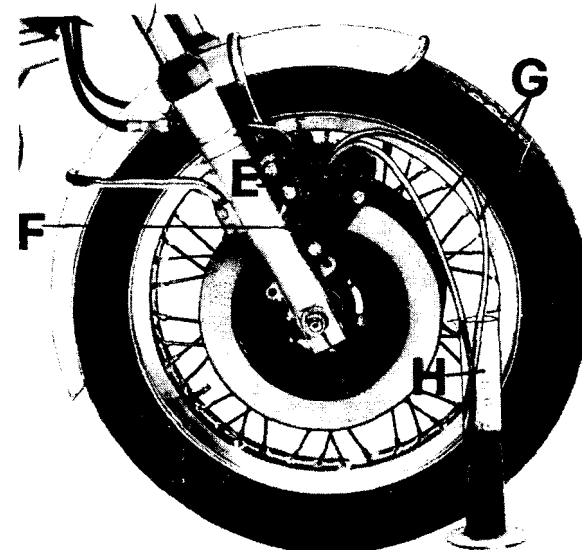
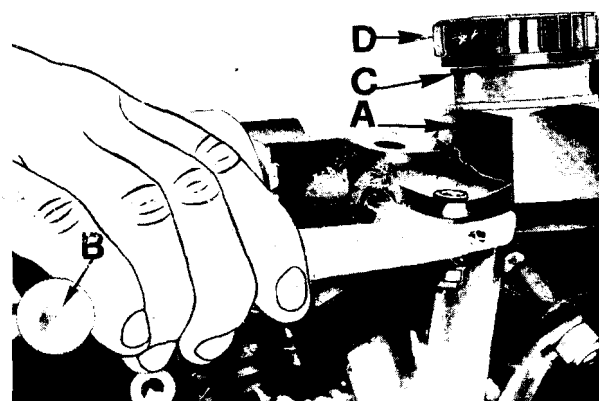
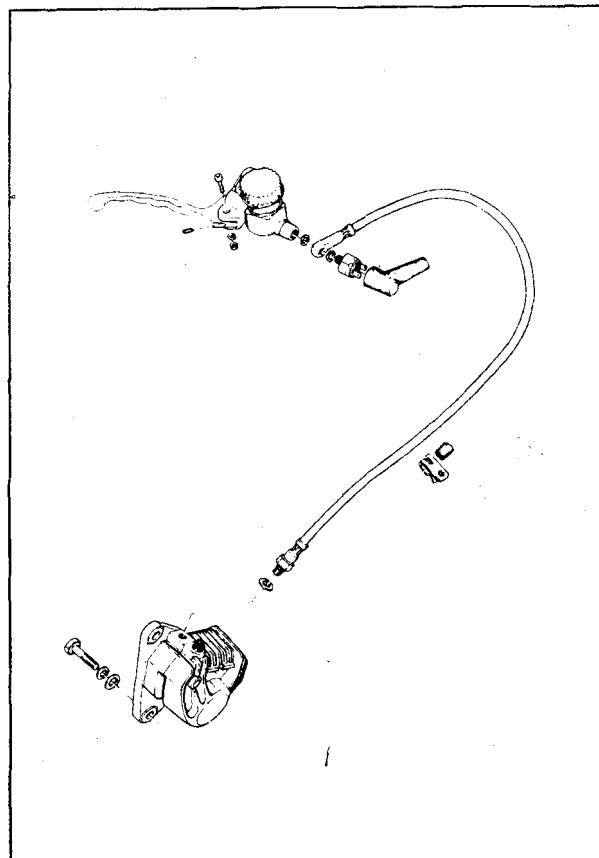

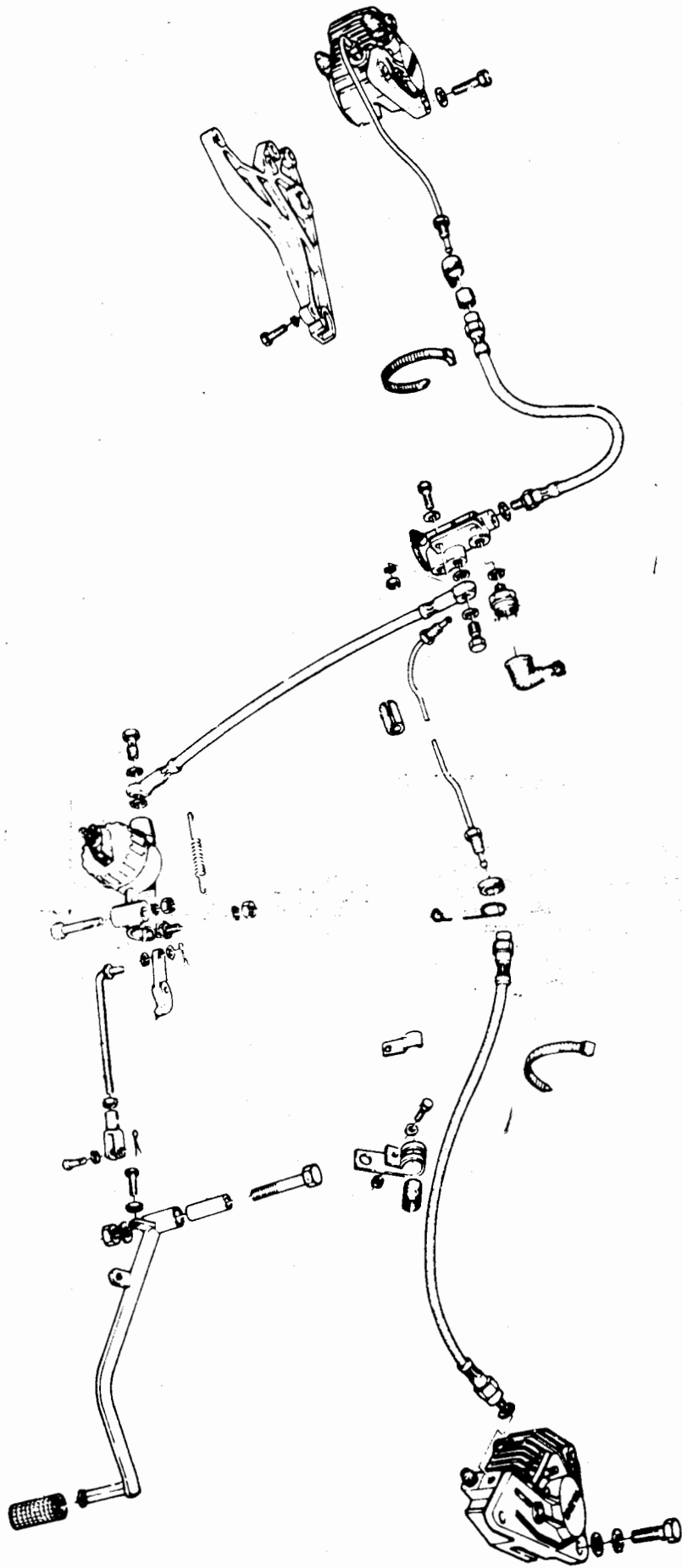

4 Air bleeding from the brake circuits 1000 SP (fig. 167-168)

This operation is required whenever the movement of the control levers is long and elastic due to the presence of air bubbles in the circuits.

Braking circuit for right front brake (fig. 167)

- Turn the reservoir until the master-cylinder-reservoir assembly reaches the horizontal position.
- If necessary, top up fluid reservoir «A», ensuring that during the bleeding operation the fluid level does not drop below the transparent section.
By acting on caliper «E»:

1 Take off rubber caps «M» and on drain plug «F» fit a transparent flexible pipe «G» of which the other end is plunged into a transparent container «H» partially filled up with fluid of the same type.

2 Loosen drain plug «F».

3 Pull handlebar control lever «B» and release it slowly, waiting a few seconds before pulling it again. Repeat the operation several times until airless fluid comes out from the pipe at the container end.

4 Keep control lever «B» fully pulled and tighten drain plug «F». Then remove pipe «G» and refit rubber caps «M» on the drain plug.

if the air bleeding operation has been carried out correctly, the efficiency of the braking action will be immediately felt after the initial movement of lever «B».

If not, repeat the operation.

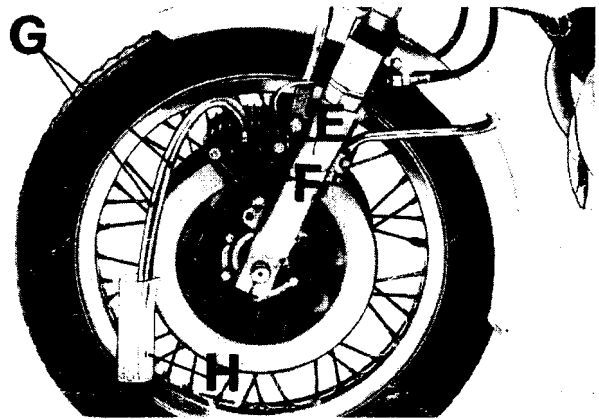

5. FRONT LEFT AND REAR BRAKE CIRCUITS

Bleeding the air from the master cylinder to the pressure control valve (fig. 168)

1 Fill up reservoir «I» (fig. 169), ensuring that during the bleeding operation the fluid does not drop below the minimum level.

2 Bleed the air from control valve «L»:

- fit a transparent pipe «G» on drain plug «F» with the other pipe end plunged into a transparent container «H» partially filled up with fluid of the same type;

- loosen plug «F».

3 Operate the brake control pedal «F» (fig. 169) releasing it slowly and waiting a few seconds before pushing it down again. Do this several times until pipe end «G» plunged into the container emits airless fluid.

4 Keep pedal «F» fully pressed down and lock drain plug «F» (fig. 169). Remove pipe «G» and refit rubber cap «M» on drain plug «F».

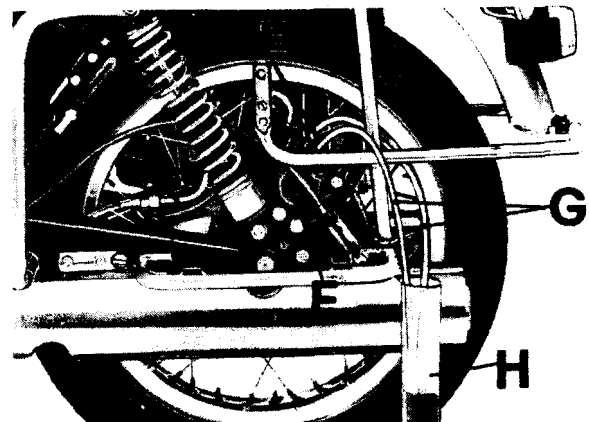
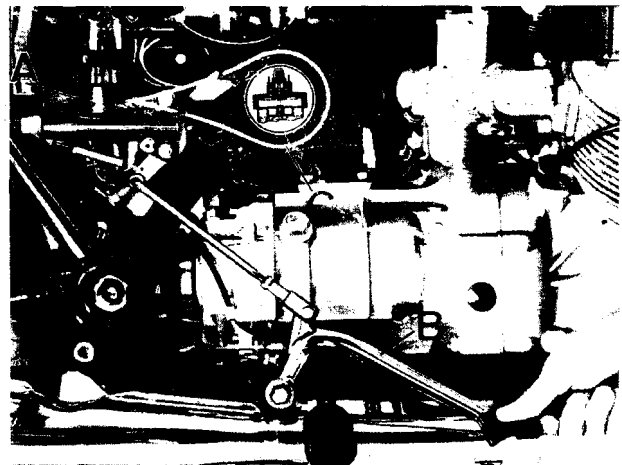

Bleeding the air from the flow control valve and the rear wheel brake disc caliper (fig. 168)

Proceed as previously except point 2 which is replaced as follows:

2 After removing rubber cap «M», on drain plug

«F» of caliper «E» on the L/H swing fork arm fit transparent flexible pipe «G» with the other end immersed in transparent container «H» partially filled with fluid of same type.

Bleeding the air from the pressure control valve to the caliper on the L/H fork cover (fig. 168)

Proceed as previously described (points 1, 3, 4) while point 2 is replaced by:

2 Remove rubber cap «M» and on drain plug «F» of L/H caliper «E» fit transparent pipe «G» with the other end plunged in container «H» partially filled with fluid of same type.

If the air bleeding operation from the front left and rear brake circuits has been done correctly, the efficiency of the braking action will be felt immediately after the initial run of the pedal. If not, repeat the operation.

6 Checking the brake fluid level and changing the brake fluid in the reservoirs-master cylinders (fig. 167-168 - 1000 SP)

For good brake operation, these directions should be followed strictly:

1 Check the fluid level frequently. It should never be below the transparent section «C» of reservoir «A».

2 Periodically, or whenever necessary, top up reservoir «A» after loosening cap «D» and removing the gaiter (fig. 167).

The fluid level for the left front and rear brake reservoir is indicated by a warning light (10 in fig. 11) on the panel which is connected to solenoid «H» on the plug (see fig. 169).

To top up this reservoir it is necessary to undo plug «H» of master cylinder «I» (fig. 169), after disconnecting all electrical cables. To top up use only fresh fluid taken from sealed containers to be opened just before use.

3 Every 15.000 km (9500 miles) or at least once a year renew the brake fluid completely.

The fuel pipes should always be full and without air; a long and elastic movement of control lever «B» evidences the presence of air inside the pipes.

When cleaning the braking circuits, use only fresh fluid.

Under no circumstances, should alcohol be used for cleaning or compressed air for drying. For metal parts use Trichloroethylene. Fluid to be used: Agip F. 1. Brake Fluid SAE J 1703 B.

7 General procedure to be followed in removing any of the braking circuit components

All external parts of the brake circuits should be cleaned thoroughly before any attempt is made to dismantle them. Plug up the pipe ends to prevent the entrance of foreign matter.

All dismantled metal parts should be cleaned with trichloroethylene while brake fluid has to be used for the rubber components.

Ensure that no trichloroethylene gets in touch with rubber parts. Handle highly precise parts with great

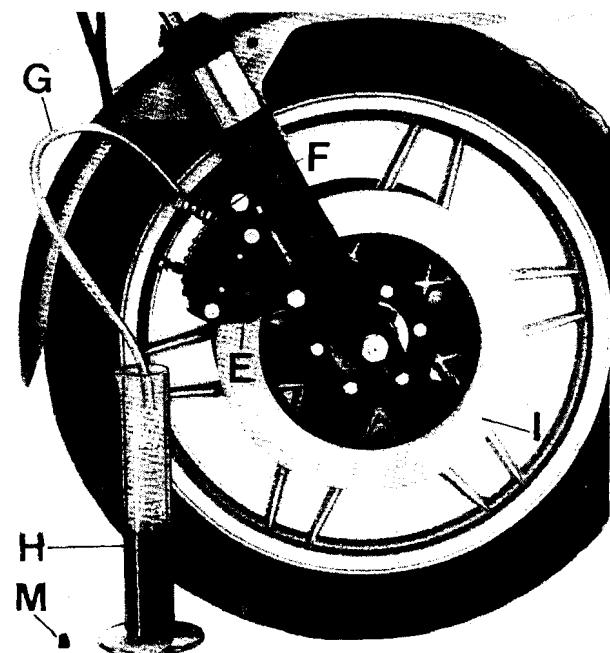
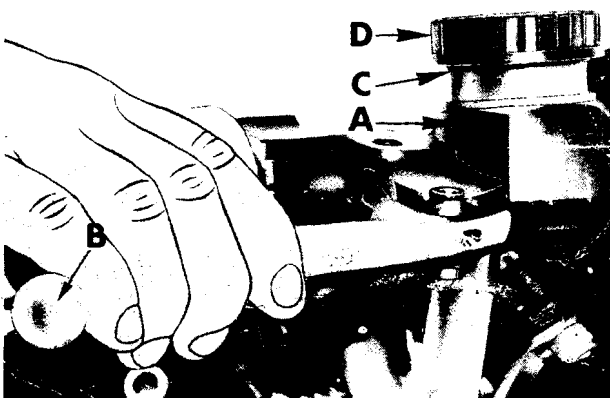

care to avoid possible damages. After cleaning dry up all parts with a clean cloth and lightly smear the cylinder walls and piston with brake fluid to avoid corrosion.

23.11 MASTER CYLINDER FOR THE RIGHT FRONT BRAKE (fig. 170)

It is located on the R/H side of the handlebar. Ensure that there is a clearance of 0.05-0.15 mm (.0019-.0059") between floater and lever end on the master cylinder.

If not, adjust as described in para 6.2.

Periodically lubricate scraper ring «7» and the stem of floater «4» using the specified fluid.

Never use mineral oil or grease.

Overhaul and replacement of parts for the right front master cylinder

Tools to be used

In case of improper operation of the master cylinder (fluid leakage at the lever end with decreased braking efficiency), it is necessary to change gasket «5» as follows:

- 1 Drain fluid from the reservoir.
- 2 Disconnect the pipe from master cylinder to right front caliper.
- 3 Plug up all pipes.
- 4 Remove master cylinder from the handlebar after taking off the throttle grip and the starter button.
- 5 Remove control lever from body «2» after undoing nut «17», washers «16» and «14», also screw «15».
- 6 Insert tool 14 92 64 00 (4 in fig. 171) into the fluid passage hole and by lightly tapping with a mallet push floater «4» outwards, making sure not to score or scratch the hole walls and the outer surface of the floater.
- 7 From the floater remove scraper «7», locking «6», and lip seal «5».
- 8 From master cylinder remove return spring «3».
- 9 If necessary, remove plug «12» with gaiter «9».
- 10 Clean floater and master cylinder body accurately, checking if scored or damaged. Check also I/D of master cylinder body and O/D of floater. Max allowed I/D of master cylinder hole 12.843 mm (.5055").
Min allowed O/D of floater 12.657 mm (.4982").
- 11 Fit new gasket on floater «5» using tool 18 92 65 00 (5 in fig. 172) and N. 18 92 66 00 (7 in fig. 172). Pay attention to the mounting position of gasket «5».
- 12 Fit locking «6», scraper «7», washer «8» and return spring «3» on floater.
- 13 Fit the whole assembly in the master cylinder hole, fit locking «8» in its housing using tool 18 92 67 00 (9 in fig. 172) and a mallet to tap until the washer is at its travel end.
- 14 Refit control lever on master cylinder «2», securing in with screws «15», washers «14» and «16», and nut «17».

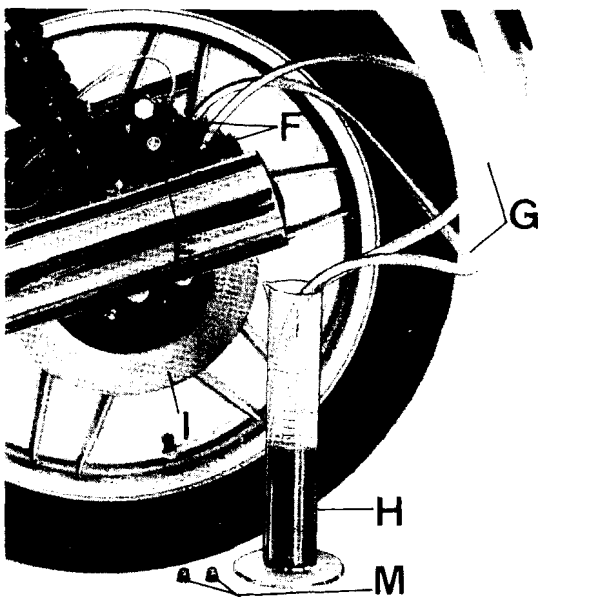
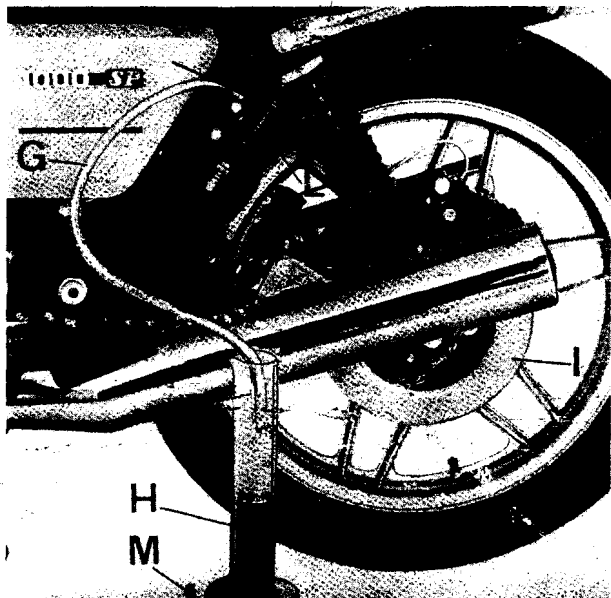
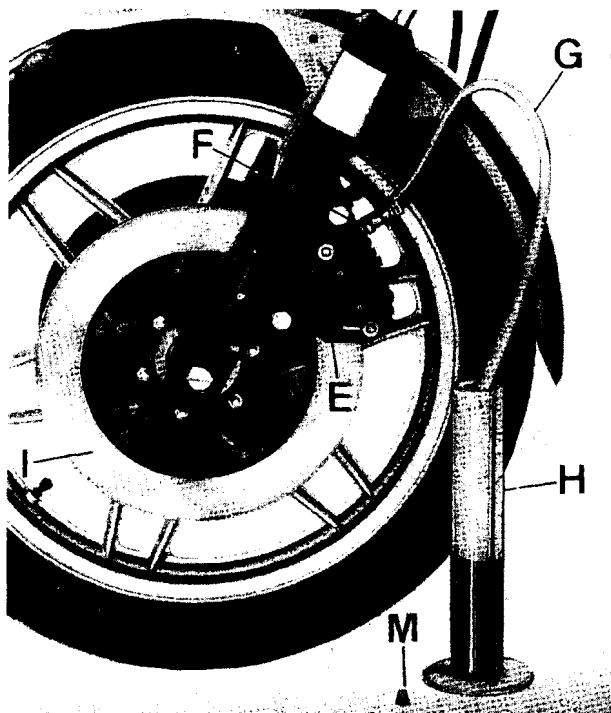

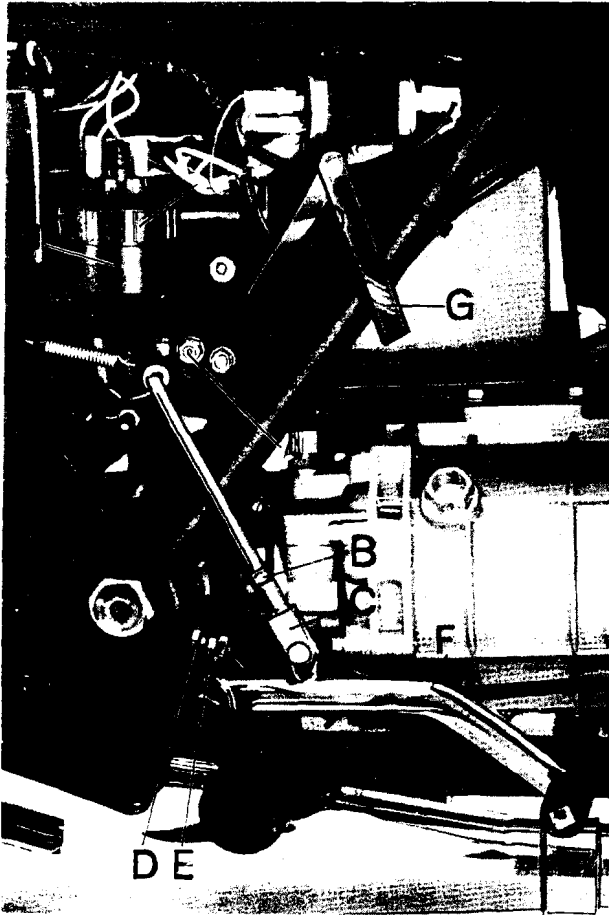

169

15 Refit the complete master cylinder on the R/H side handlebar, the twist grip control, and the start-stop switch.

16 Connect the fluid delivery pipe from caliper to master cylinder body.

17 Check clearance between floater and lever end on the right front brake master cylinder.

18 Fill up fluid reservoir and bleed the air from the braking circuit.

19 Refit gaiter «9» and screw in plug «12».

Note - Before mounting moisten all metal and rubber parts with brake fluid or recommended grease. **Never use mineral oils or greases.**

23.12 MASTER CYLINDER FOR LEFT FRONT AND REAR BRAKES (fig. 173)

It is centrally located on the R/H side of the vehicle. Remove the R/H side cover to get access to it. Ensure there is a 0.05-0.15 mm (.0019-.0059") clearance between floater and lever end on the master cylinder. If not, adjust to correct clearance. Periodically lubricate scraper ring «9» and floater stem «5», using brake fluid. **Under no circumstances whatever mineral oils or greases should be used.**

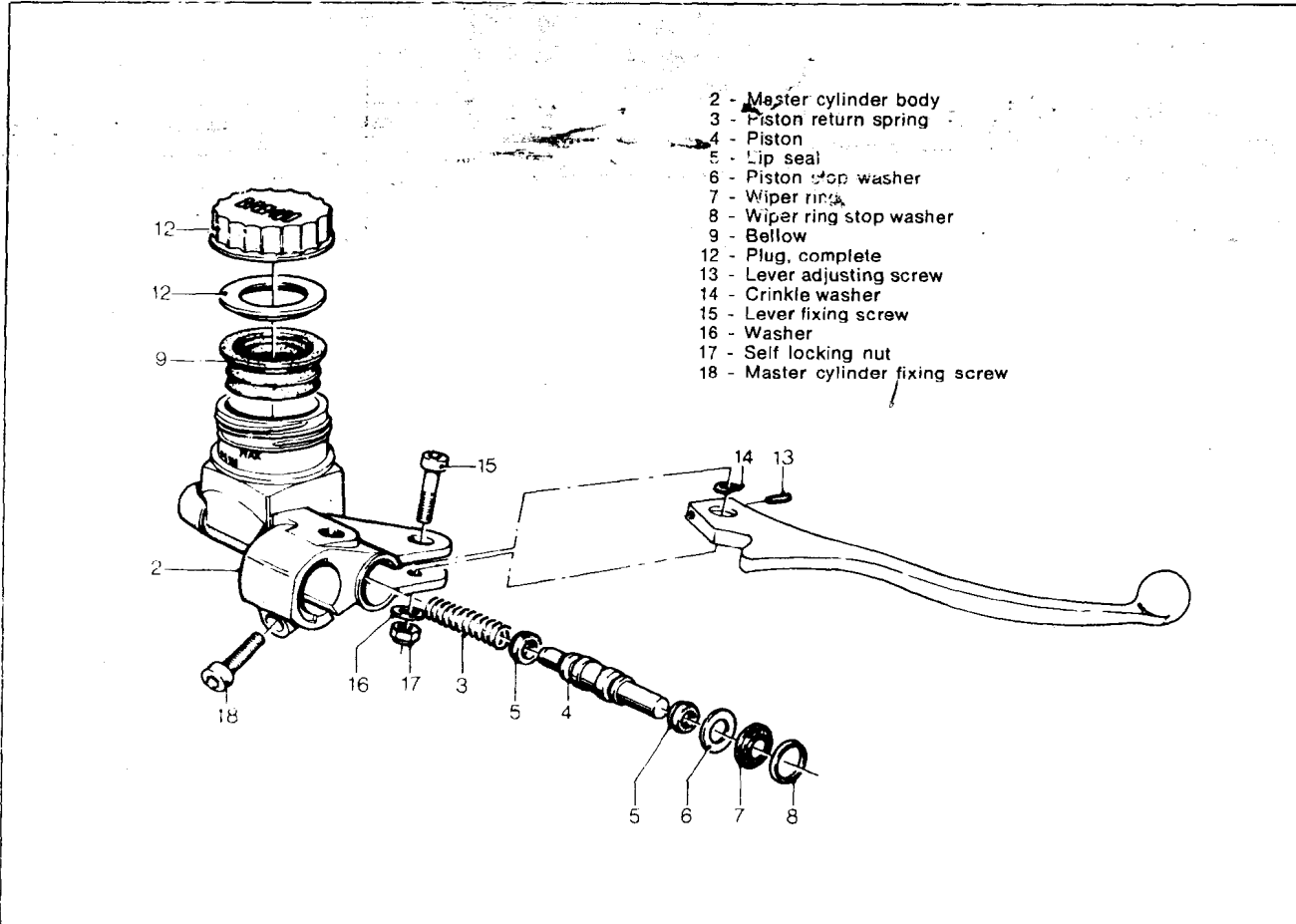

170

Overhauls and replacing components of the L/H and rear brakes master cylinder

- 1 Disconnect the fluid delivery pipe from reservoir to banjo union (for model 1000 SP from reservoir to the union with pressure control valve).
- 2 Drain the fluid from the reservoir.
- 3 Plug up fluid delivery pipe.
- 4 Remove master cylinder from frame.
- 5 Undo nut «17» with washer «16» and remove lever screw «18» and the lever from the master cylinder body.
- 6 Fit tool 14 92 64 00 (4 in fig. 171) into the fluid passage hole and push out floater «5» by lightly tapping with a mallet, taking care not to score or scratch the hole walls or the outer surface of the floater «5».
- 7 From floater «5» remove scraper ring 9, locking «8», and lip seal «7». From the other side remove toroidal gasket «6».
- 8 From the pump body («2») remove return spring «4» and spring guide cap «3».
- 9 If necessary, remove plug complete with gasket «14».
- 10 Clean accurately floater and master cylinder, checking for any scoring or damages. Check also I/D of master cylinder and O/D of floater.
 Max allowable hole dia. 15.918 mm (.626").
 Max allowable floater dia. 15.832 mm (.622").

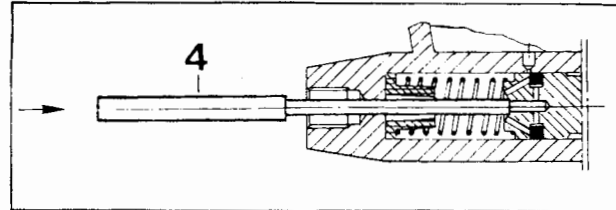

171

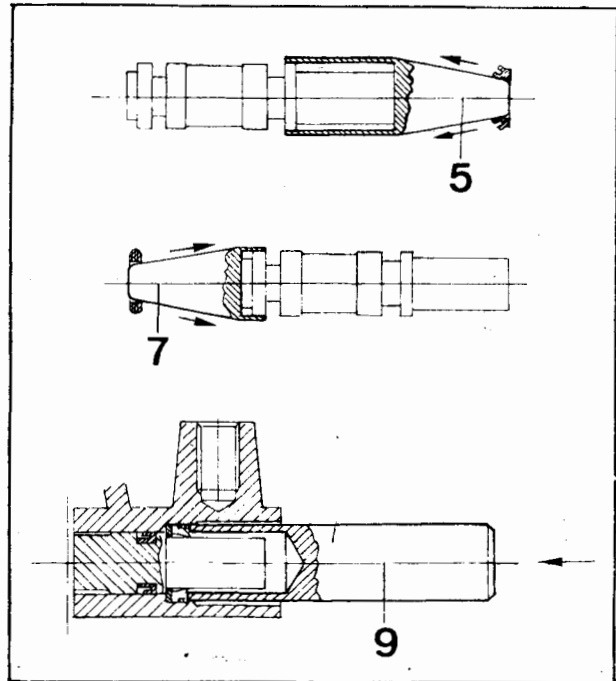

172

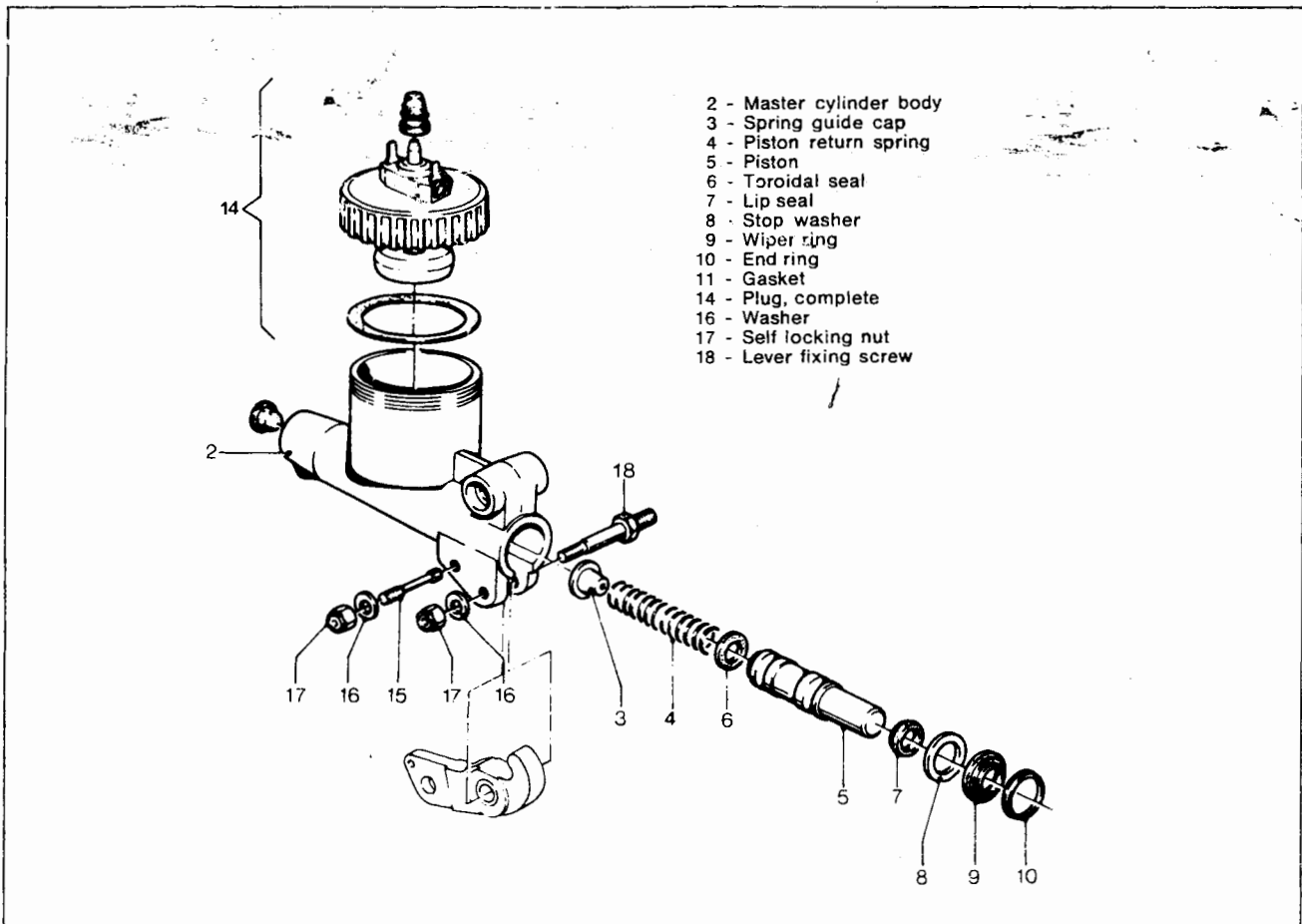

173

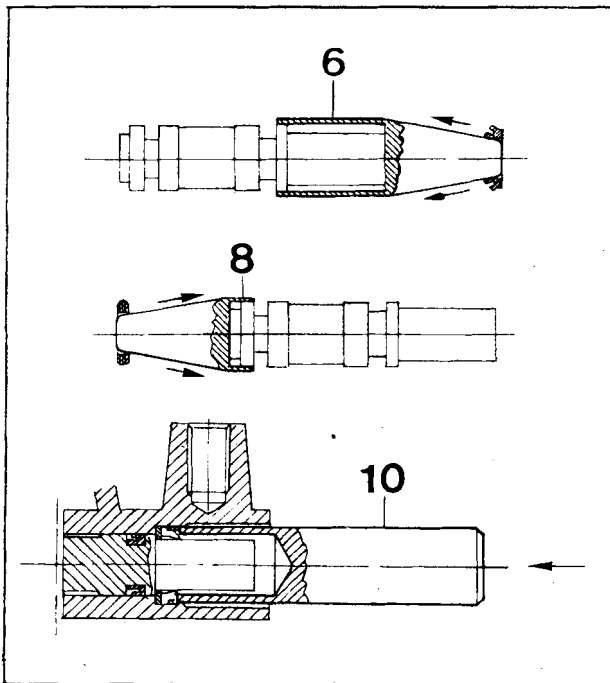

174

11 Refit gasket «7» on floater using tool 14 92 65 00 (6 in fig. 174) and gasket «6» using tool 14 92 66 00 (8 in fig. 174).

12 On floater assemble stop washer «8», scraper ring «9», and insert return spring «4» with guide «3» on floater.

13 Fit the entire assembly in the master cylinder hole, fit scraper ring retainer «10» in its housing using a mallet to tap on tool 14 92 67 00 (10 fig. 174) until the retainer is heard to click home.

14 Refit the complete master cylinder on the frame.

15 Refit control lever on master cylinder body, securing it with screw «18», washer «16», and nut «17».

16 Connect the fuel delivery pipe from master cylinder to connector (for model 1000 SP from master cylinder to the connector with pressure control valve).

17 Re-check clearance between floater and lever end on the master cylinder. To adjust, operate on screws «15», after undoing nut «17», till the correct distance is reached.

18 Fill up the reservoir with fluid up to its maximum level.

19 Fully screw in plug and washer «14» on the pump body.

NB Before mounting lightly moisten the rubber and metal parts with brake fluid: **under no circumstances use mineral oils or greases.**

23.13 BRAKE CALIPERS (FRONT LEFT AND REAR FOR MODEL V 1000 G 5 - REAR FOR 1000 SP (fig. 175)

1 The calipers consist of two light alloy bodies «2» and «3» joined up by two screws «8».

2 A round housing is machined in each caliper half which acts as a piston guide («5»).

3 Sealing is ensured by a gasket («4») lodged in a groove inside the cylinder.

4 The sealing is automatically adjusted as with the wearing of pads «9», the piston exit out of the cylinder housings increases.

5 Dust cap «6» prevents the entrance of moistness and foreign matter.

6 The 2 pistons act directly on the 2 pads which are secured by 2 pins «10». Taper pin «12» pressed by spring «11» prevents pad flapping and makes disc setting easier after braking.

7 Cover «13», elastically mounted on top of the caliper prevents the pads from getting too much wet.

8 Brake fluid is delivered to caliper through the hole in the half body. Hydraulic connection between caliper bodies is through two inner holes. Sealing is assured by gasket «7». Each caliper body is provided with a drain plug «14» for air draining.

23.14 FRONT BRAKE CALIPER - 1000 SP (fig. 176)

It is the same as for model V 1000 G 5 except that the drain plug is fitted on the caliper without any ear.

A Inspections and controls (fig. 177)

Every 5000 km (3000 miles) check pad wear as follows:

- Remove cap «A».
- Remove taper pin band «D», spring «I», and pin «C».
- Extract the pads. Thickness should be:
 - new pad 9 mm (.354");
 - wear limit 6 mm (.236").

If under the wear limit, replace the pads. The friction material should never be used to the point where the metal plate comes to the surface as if this contacts the disc irreparable damage would ensue and there would be no friction for thermal insulation between fluid and pad.

Replace pads as follows:

- Push the pistons into the caliper bodies with care so as not to damage the dust caps.
- Fit new pads «E».
- Fit pad retaining pins, spring, and center pin. pin «B».

After these pad replacing operations it is not necessary to bleed the air from the braking circuits.

All that needs to be done is to actuate the handlebar control lever or pedal several times until the plungers return to their normal position (pads about 0.2 mm (.0078") away from the disc).

Important Do not brake vigorously on new pads but allow them to settle down completely.

NB When replacing the pads it is well to drain some fluid from the reservoir as the return of the plungers into the cylinder may cause overflowing in the reservoir.

B Inspection and replacement of caliper components

The replacement of the sealing gaskets is necessary when fluid leakages occur. Fluid traces will be seen on the brake discs and calipers and the fluid level in the reservoirs will get lower and lower. Fluid leakages also involve poor braking efficiency and an elastic movement of the control lever or pedal.

The caliper gaskets are replaced as follows:

- 1 Remove and plug up fluid delivery pipe.
- 2 Remove caliper from fork members.
- 3 Remove the pad housing cover.
- 4 Remove spring and pins and take out pads.
- 5 Separate both half-calipers.
- 6 Remove dust guard cap from the leaking caliper body.
- 7 Remove piston from caliper half using a compressed air jet, paying attention not to score the piston surface.
- 8 Remove the defective gasket from its housing by the aid of a needle taking care not to score the cylinder walls.
- 9 Clean accurately the piston and cylinder housing, checking their condition. It is well also to check I/D of the cylinder housing and O/D of the piston.

Calipers for front and rear brakes, V 1000 G 5 and front only for 1000 SP

Max admissible cylinder housing dia. 38.071 mm (1.497").

Max admissible piston dia. 37.936 mm (1.493").

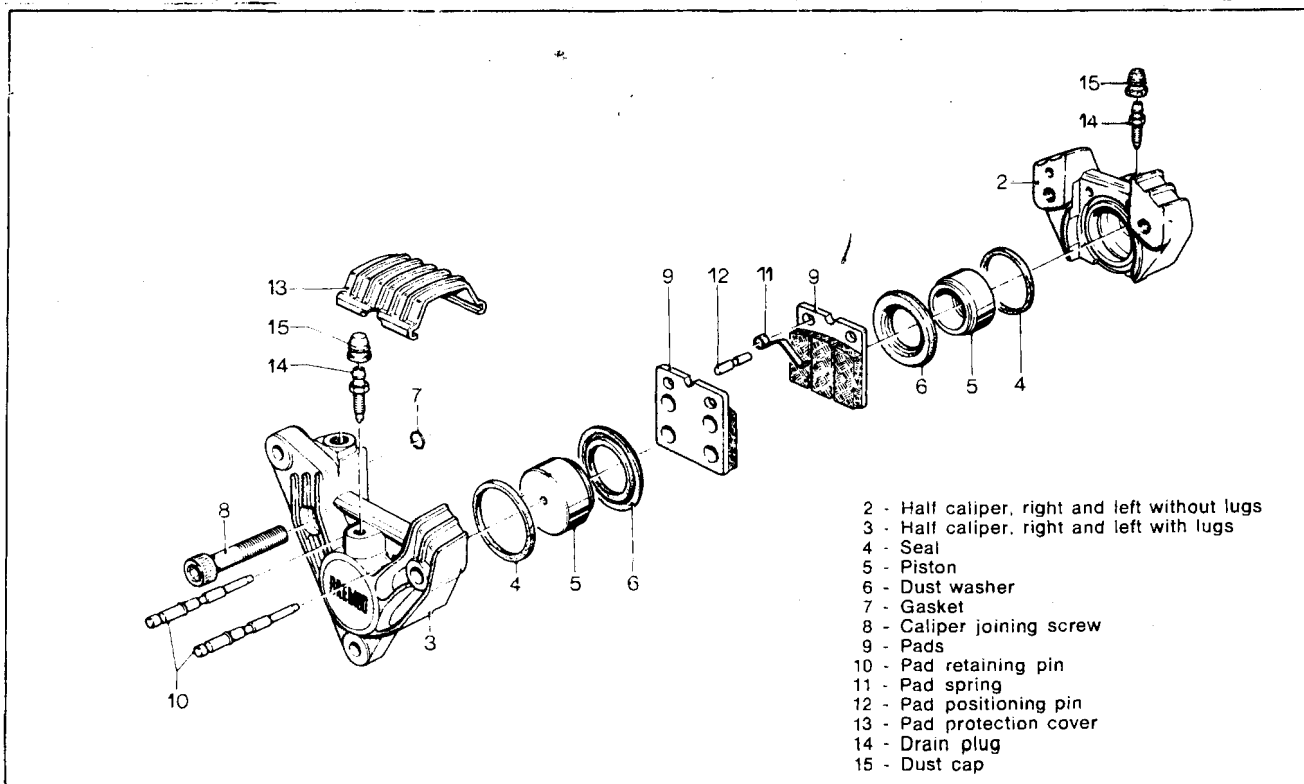

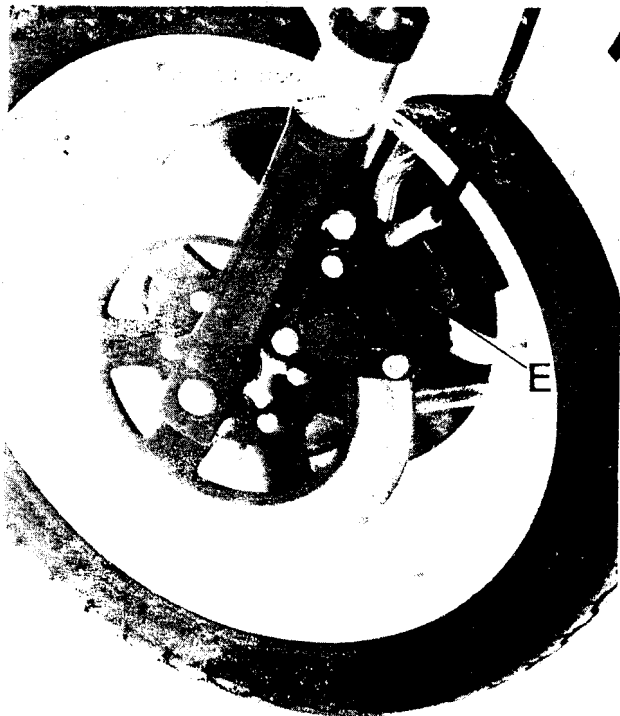
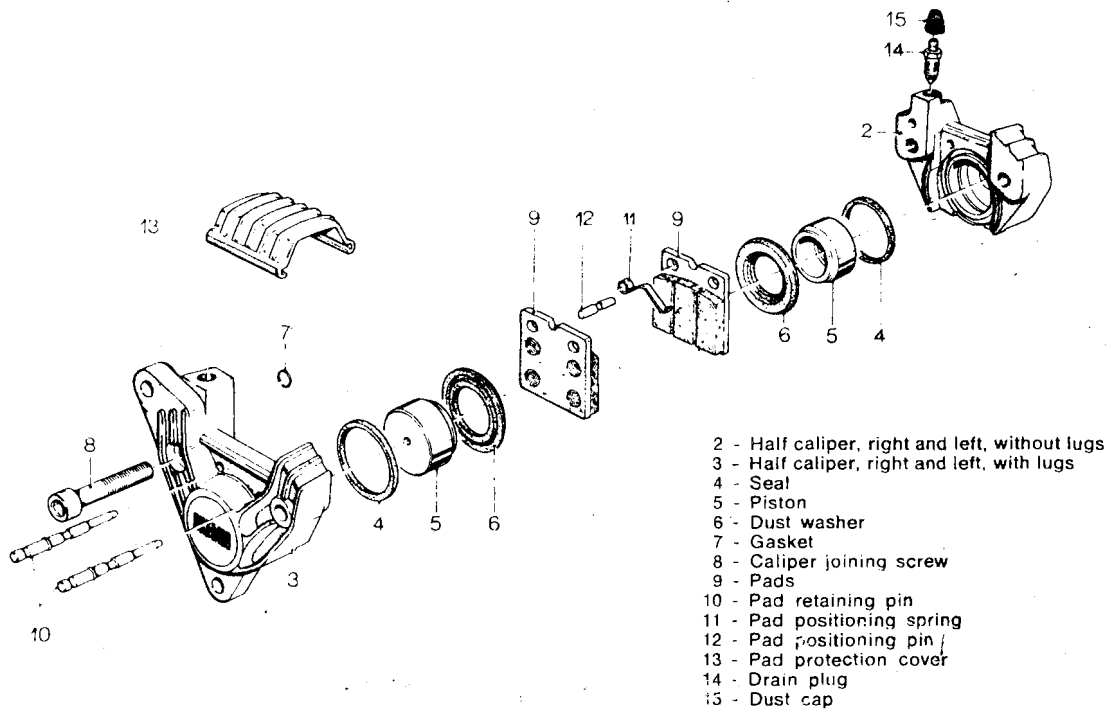

Caliper for rear brake - 1000 SP

Max cylinder housing dia. 48.071 mm (1.890").
 Max piston dia. 47.936 mm (1.887").

- 10 Fit a new gasket in cylinder housing groove.
- 11 Fit piston in cylinder housing (introduce this by finger pressure only).
- 12 Fit dust guard cap checking for any damage and secure it in its housing on both piston and caliper bodies.
- 13 Join the two caliper bodies, taking care that the gasket is properly lodged in its housing. Tighten the screws to a torque wrench load of 4-4.5 kgm (29-33 lbs ft).
- 14 Reassemble caliper on fork member, screwing in its securing screws to a torque wrench load of 4 ÷ 4.5 kgm (29-33 lbs /ft).
- 15 Fit pads on pins, pin retainer, and spring with tapered pin.
- 16 Connect fluid delivery pipe to caliper.
- 17 Bleed the air from the braking circuit. **Do not use mineral oils or greases.**

23.15 BRAKE PADS

Brake pads are marked as follows:

V 1000 G 5

- front right and rear (white) FERIT I/D 332 GG;
- front left (red) FERIT I/D 330 FF.

1000 SP

- front (white) FERIT I/D 322 GG;
- rear (blue) FERIT I/D 334 FG.

23.16 PIPES

Check the condition of all flexible pipes accurately. If in any way damaged, replace them immediately.

23.17 BRAKING DISCS

The braking discs are rotating bodies contacted by the pads during the braking action. Consequently, their features can markedly affect braking efficiency. For use on motorcycles, the disc surface has been specially treated to prevent oxidation. The same treatment is done on the disc braking parts but after a few brakings this protection wears off and creates ideal conditions for correct pad-disc coupling.

Inspection and checks

It is very important for the disc to be perfectly clean without any rusting, oil, grease or other impurities and free from scoring. Damaged discs should be dis-

mantled and ground on a special machine; the maximum admissible offsets in a disc are:

- parallelism of contact surface with disc braking section: 0.050 mm (.0019");
- flatness of braking surface: 0.050 mm (.0019");
- parallelism of the disc circular braking part: 0.015 mm (.00059");
- parallelism of disc braking part (radial check): 0.060 mm (.0023").

Disc diameters

Front disc dia.	Rear disc dia.
300 mm (11.811")	242 mm (9.52")

Thickness of front and rear discs

Original	Minimum
6.250-6.450 mm (.246-.254")	5,800 mm (.228")

In case of disc replacement or overhauling, it is necessary to check disc «floating» with a gauge, ensuring that the reading is no more than 0.2 mm (.0078").

If more than this, check the disc mounting position on the hub, also wheel bearing play.

The discs are bolted to the hub with a torque wrench set at 2.2-2.4 kgm (16-18 ft./lbs).

23.18 BRAKING CIRCUIT FAULTS

CAUSE	REMEDY
<p>Brake screeches</p> <p>Caliper not completely tightened Defective or missing springs Pad excessively worn out Greasy or oily pads Incorrect type pads fitted</p>	<p>Screw in securing screw Fit new pin Fit new pads, after checking condition of disc Replace pads Replace pads</p>
<p>Excessive disc overheating on normal riding</p> <p>Pistons jammed, pads stuck to disc No play at control lever</p>	<p>Check piston conditions, clean pad housing in caliper Adjust lever play as directed</p>
<p>Poor braking</p> <p>Oily or greasy disc Excessively worn or vitrified pads Oily or greasy pads Jammed pistons</p>	<p>Clean disc Replace pads, check disc Replace pads Free pistons</p>
<p>Brake locks</p> <p>Friction coefficient of pads too high High disc oxidation</p>	<p>Fit correct pads Grind in disc</p>

CAUSE	REMEDY
<p>High pad wear</p> <p>Pad locked in housing, braking disc constantly touching Pistons jammed Disc deeply scored</p>	<p>Clean pad housing in caliper, check if properly housed in guides Restore sliding condition Grind or replace disc</p>
<p>Irregular or slantway pad wear</p> <p>Dirty pad housing Poor sliding of pistons Defective pad spring Caliper mounted slantways</p>	<p>Clean pad housings Restore proper sliding condition Replace spring Check and mount properly</p>
<p>Control lever or pedal too long</p> <p>Brake disc floating more than 0.2 mm (.0078") Air bubbles in braking circuit Brake disc deeply scored</p>	<p>Grind or replace disc Bleed the air Grind or replace disc</p>
<p>Non-return of master cylinder floater</p> <p>Staple securing screws too tight Lever securing bolt too tight (non original bolt) Lever-housing incorrectly coupled in master cylinder Scraper ring deformed by etching liquid Dirty brake fluid</p> <p>Defective floater return spring</p>	<p>Partially slacken screws Partially slacken bolt Replace lever</p> <p>Replace scraper ring Strip, check and clean master cylinder components (no seizing or scoring marks admitted). replace fluid Replace spring</p>
<p>Fluid leakages from reservoir</p> <p>Gaiter not properly positioned</p> <p>Damaged gaiter Damage fluid reservoir rim</p>	<p>Fit gaiter properly in its housing and gently close cap Replace gaiter Repair or replace reservoir</p>

23.19 RECOMMENDATIONS

All rubber parts of the braking circuits (for master cylinder: gaskets, scraper ring and gaiter; for caliper halves: gasket and dust guard cap) are made of a special compound resisting to brake fluid. These parts, however, cannot stand the etching action of mineral oils, solvents and/or diesel oil which are sometimes used to wash down the machine. Accordingly, it is strongly recommended to avoid contact of these liquids with the rubber parts in the circuit. For instance, it may occur that the master cylinder scraper, with contact with gasoline or diesel oil, will melt and glues to the floater, affecting its sliding action.

The caliper gaskets are subject to sticking to the piston

It is sometimes possible that during storage of the calipers before assembly or when the machine itself is left unused for long periods of time, in a relative short period (for instance 2-4 months according to the influence of negative factors such as machining tolerances, tolerances in the compound, ambient conditions etc.) this phenomenon may occur. non may occur.

Should this happen, operate as follows:

- a Actuate the control lever or pedal several times until the correct pad-disc clearance is restored.
- b If this leads to no results:

- remove plastic cap from caliper;
- remove a pad and actuate the master cylinder so as to allow the piston to come out of its housing by 4-6 mm (.15-.23");
- return the piston to its original position, avoiding damages to it, its rubber parts, and the disc;
- refit the pad;
- proceed likewise for the other pad;
- operate as at a);

NB When carrying out these operations, make sure not to change the position of the pads.

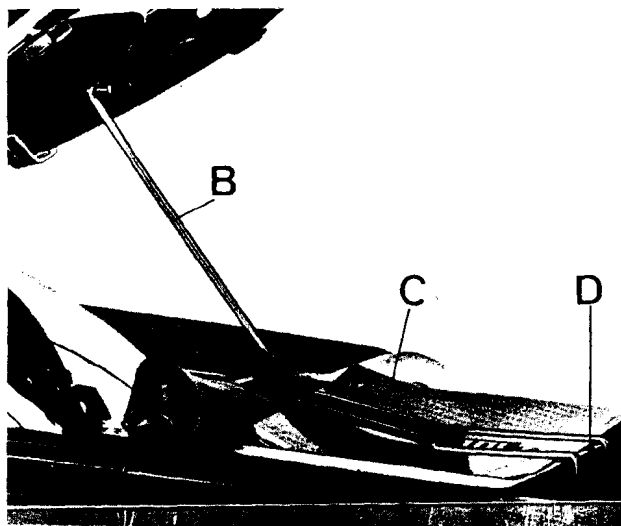

The electrical equipment consists of:

- battery;
- electromagnetic control starter motor;
- generator-alternator mounted on the front end of the crankshaft;
- twin contact breaker with automatic advance;
- ignition coils;
- rectifier;
- regulator;
- fuse block (6 fuses 16A);
- flashing light relay;
- starter relay;
- headlight;
- tail, stop, and number plate light;
- turn signal lamps;
- ignition key switch;
- light switch;
- turn light, horn, flashlight switch;
- engine start and stop switch;
- horn (V 1000 G 5 Model);
- horns (twin, 1000 SP).

24.1 BATTERY (fig. 178)

The battery is a 12 V type with a capacity of 32 Ah, directly charged by the generator.

To access to the battery:

- shift lever «A» to free the saddle;
- raise the saddle and keep it up with rod «B»;
- unhook rubber band «C»;
- remove tool box «D».

A Putting a new dry battery in service

- 1 Remove sealing tape and plugs. Introduce pure sulphuric acid for battery with a specific gravity of 1.26 kg/l and a temperature of not less than + 15° C (59° F) until the level overflows 5-10 mm (.019-.039") the plate separators or splash guard.
- 2 Let the battery at rest for about 2 hours.
- 3 Now charge the battery for 6-8 hours — intensity 1/10th of its capacity — until the acid has reached about 1.27 sp. g. and such gravity has remained constant for at least 3 consecutive hours.
- 4 After charging, top up the acid, screw in the plugs, and clean the battery cover accurately.

B Servicing the battery under service conditions

- 1 Be sure the electrolyte always covers the separators. To top up use distilled water. Never add sulphuric acid.
- 2 If too frequent water additions are required, have the electrical system checked over as the battery

works in an overcharged condition and will deteriorate quickly.

3 If the battery discharges quickly, the electrical system should also be checked over.

4 In case new or second hand batteries are left unused for fairly long periods of time, it is a good rule to re-charge them every month.

5 Always keep the battery terminals spotlessly clean and smeared with neutral vaseline.

6 Always keep the battery cover dry, avoiding overflows of electrolyte which will reduce insulation and corrode battery brackets.

NB If the batteries are for use in tropical climates (average temperature higher than 33° C (91° F) it is recommended to reduce acid gravity to 1.230.

C Measuring density and temperature of electrolyte (fig. 179)

This operation should be carried out periodically in each cell after topping up.

Use a hydrometer to check density.

Use a thermometer with its rounded end completely immersed in the liquid to check temperature.

D Correcting the specific gravity reading compared to temperature

All readings should be brought down to the standard temperature of 25° C (77° F).

For each 10° C (50° F) difference it is necessary to add or detract 7 g/l in order to bring the reading to said value of 25° C (77° F).

For example: a reading of 15° C (59° F). The corresponding gravity at 25° C (77° F) will be $1.290 - 7 = 1.283$ g/l. A reading of 35° C (95° F): the corresponding gravity brought down to 25° C shall be $1.275 + 7 = 1.282$ g/l.

This corrective factor should always be within 1.270-1.280 g/l. When measuring specific gravity, the following precautions should be taken:

- take reading at eye level holding the tube vertically and ensuring the float is free (fig. 179);
- after measurement put back the acid in the cell from which it was taken;
- If any drops of acid have dripped, dry them with a wollen cloth.

The following table shows specific ratings in respect to climate:

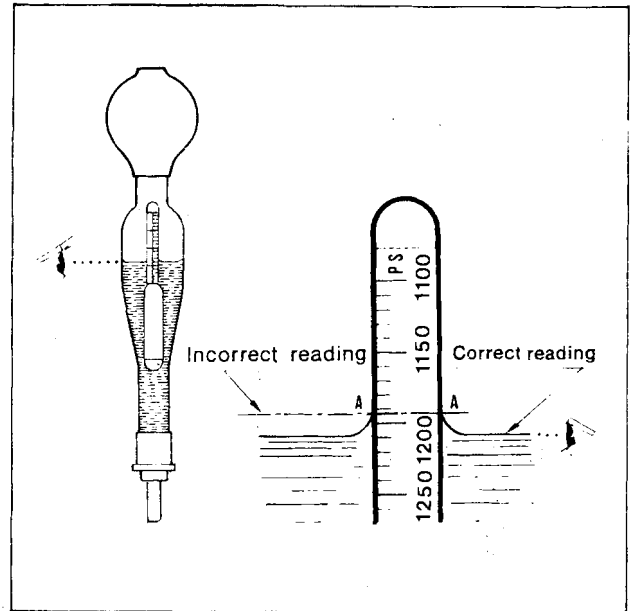

179

CLIMATE	SPECIFIC GRAVITY AT FILLING	SPECIFIC GRAVITY AT END OF CHARGE	MAX TEMPERATURE PERMISSIBLE DURING CHARGE
Temperate (normally under 32° C (89° F))	1260	1270-1280	50° C (122° F)
Tropics (normally over 32° C (89° F))	1230	1220-1230	60° C (140° F)

24.2 ALTERNATOR-GENERATOR (fig. 180)

MAIN FEATURES	BOSCH G 1 (R) 14 V 20 A 21 N. 01203400 02
Max output	280 W - 14 A
Max current intensity	20 Amp.
Starting of charge	1000 rpm.
Max permissible speed	10.000 rpm.
Direction of rotation (seen from commutator side)	Clockwise
Max eccentricity	0.06 mm (.0023")
Field winding resistance	3.4 Ohms + 10%
3-phase winding resistance of stator (A. C.)	0.36 Ohms + 10%

a Bench test control of generator

POWER TEST	LOAD	MAX RMP.
Power values (with regulator)	5 A 10 A 20 A	1.300 rpm. 2.100 rpm. 7.000 rpm.

Re-charging equipment

Control on vehicle

When the panel light indicates an irregularity in the charging system, an accurate control becomes essential. An initial check can be made without removing the generator from the vehicle with the engine not running and relatively cold in order to avoid burnings. Disconnect cable B (red cable, positive rectifier plate) and insert an amperometer-voltmeter as indicated in fig. 181. Start the engine.

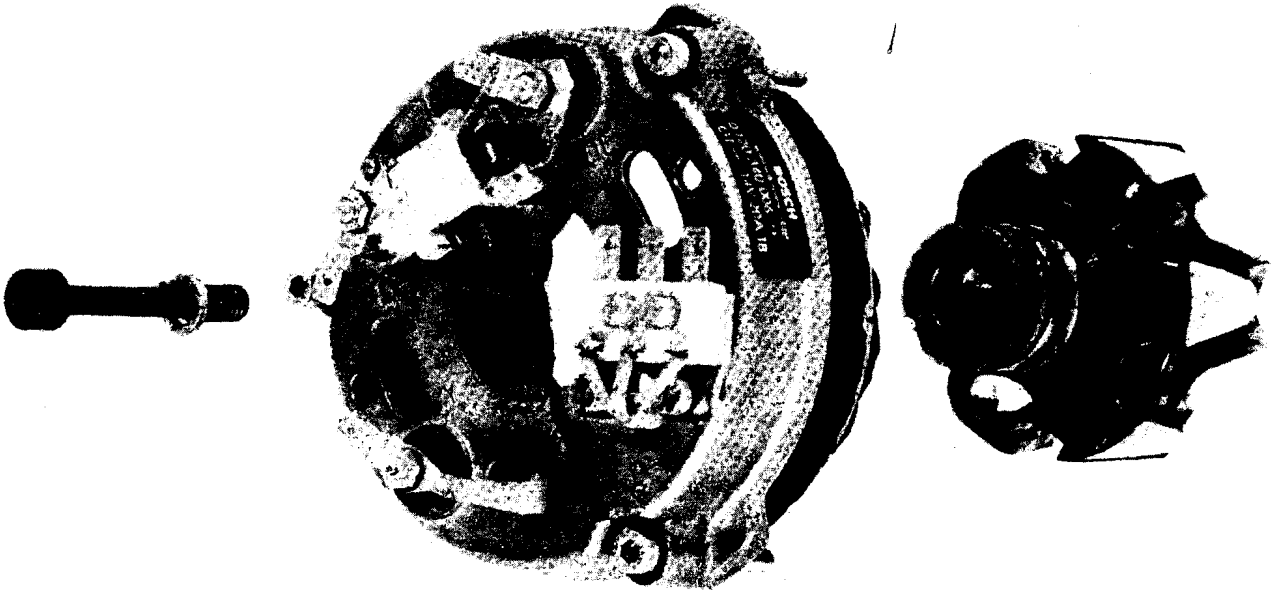

Switch on any of the electrical switches, such as the headlight, and watch load and voltage.

If the load is from 10 to 15 amperes with a voltage in between 12-13 Volts, the generator operation can be considered as normal and the fault has to be looked for elsewhere.

Check all connections accurately, especially the cables to the warning light in the panel, to the regulator and to the rectifier. If all seems to be in order but the failure persists, it is necessary to proceed with various testings.

Testing a positive diode using a ohmmetr (fig. 182)

Press the positive contact point of the ohmmeter against the anode of the diode and the other contact point against the cathode.

The diode is thus energized and the ohmmeter needle will immediately start to move in the first 3rd of the dial scale.

By reversing the diode polarity, the diode will block and the needle will stop.

As concerns the ohmmeter values, see fig. 183 and 184.

Testing a negative diode using a ohmmeter

This element works like a positive diode and accordingly by having the positive point of the ohmmeter contact the anode of the diode and with the other point in touch with the cathode, the diode will be energized and the ohmmeter needle will move suddenly in the first third of the dial scale.

By reversing the said contacts the diode de-energizes and the needle will stand still.

In regard to the ohms values, see pictures 183-184. Should a diode be found to be defective, it is necessary to change the complete diode assembly.

Resistance test for the stator winding (fig. 185)

From the alternator disconnect all cables «D» and «DF» and unplug «U-V-W». This test can easily be carried out with any of the ohmmeters available on the market or with any alternator tester.

Measure the resistance of the stator winding at exits «U-V», «U-W», «V-W». All readings should be equal. Resistance of the stator 3-phase winding (A.C.) should be 0.38 Ohms + 10%.

Rotor winding

The rotor excitation winding is measured with a ohmmeter.

It should be 3.4 Ohms + 10% (fig. 186).

After turning on the lathe, check concentricity of the slip rings (fig. 187).

Maximum admissible eccentricity 0.06 mm (.001").

Correcting faults on alternator fed systems

In case of any faults in any current producing equipment, it is necessary to ensure in the first place that the cause is not only due to malfunctions of the alternator or regulator but to some battery cable disconnection or possible faults in other points of the circuit. The following table indicates possible breakdowns, possible causes, and remedies.

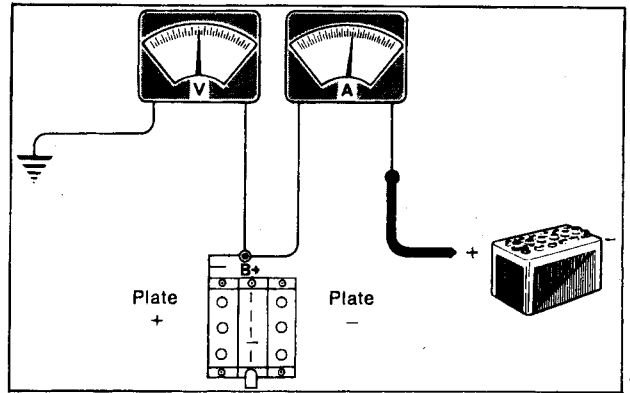

181

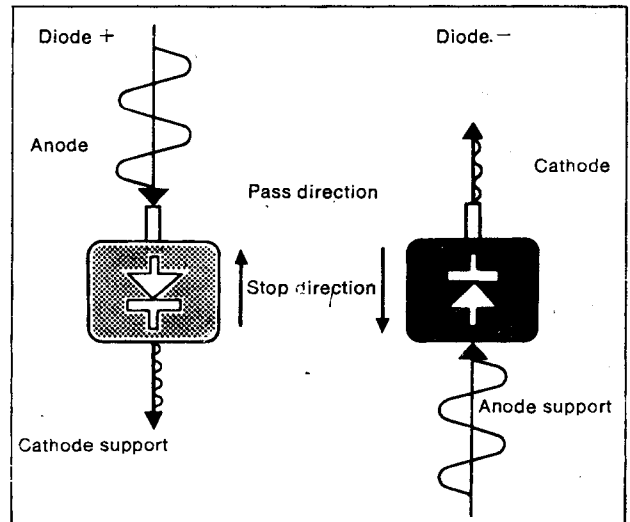

182

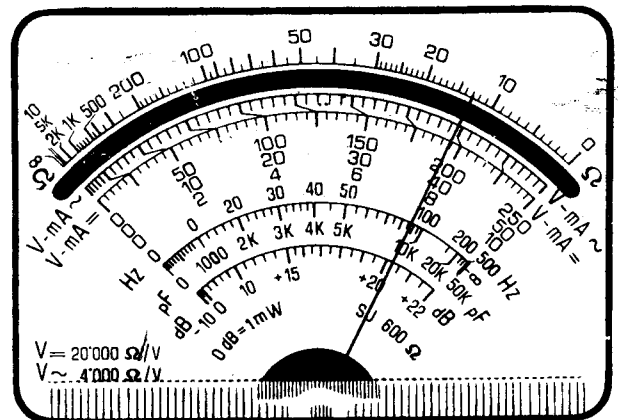

183

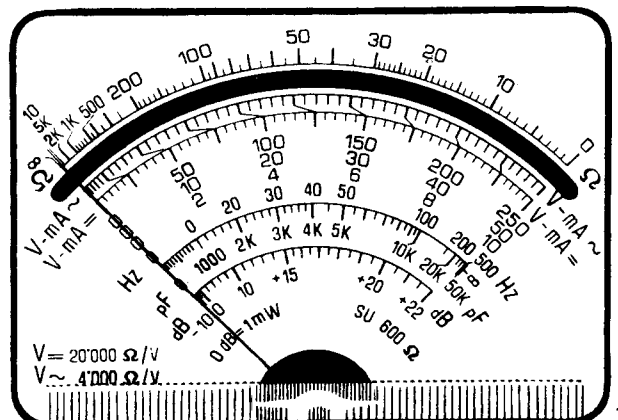

184

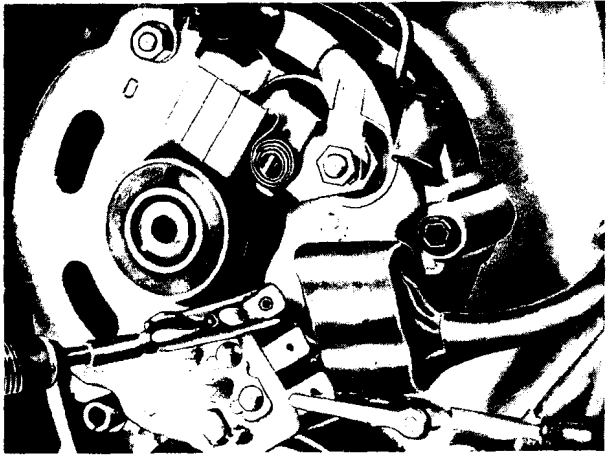

185

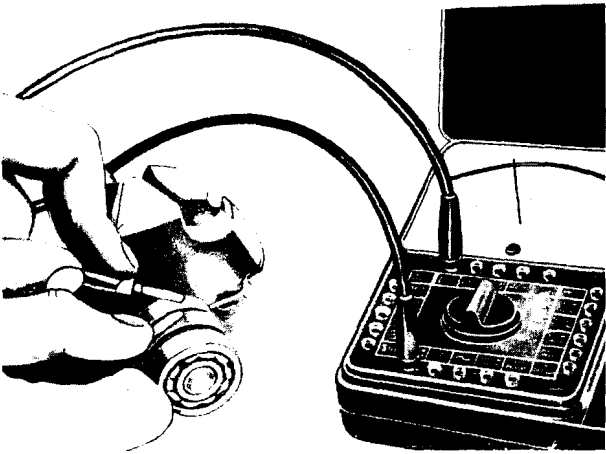

186

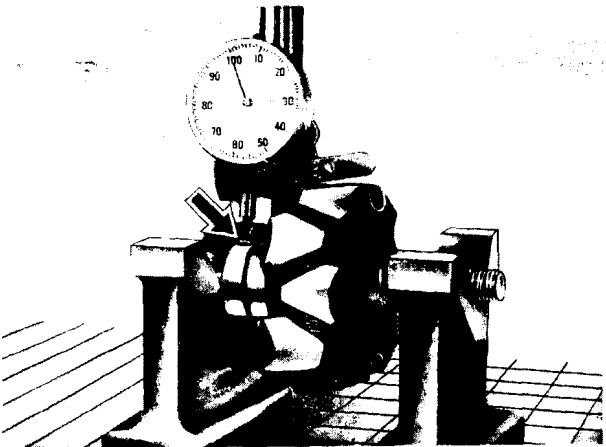

187

CAUSE	REMEDY
<p>Battery discharged or insufficiently charged</p> <ol style="list-style-type: none"> 1 Obstruction or reduced voltage in the charging circuit 2 Defective battery 3 Defective alternator 4 Defective regulator 	<ol style="list-style-type: none"> 1 Remove obstruction or reduced voltage cause 2 Replace battery 3 Have alternator repaired in a competent shop 4 Replace regulator

CAUSE	REMEDY
Generator charge light does not light up with ignition key on (Idling engine) 1 Burnt indicator bulb 2 Discharged battery 3 Defective battery 4 Damaged or disconnected cables 5 Defective regulator 6 Shorted positive diode of alternator 7 Worn out brushes 8 Slip rings oxidized, interruption of rotor winding	1 Fit new bulb 2 Charge battery from an external electric source 3 Replace battery 4 Replace or connect cables 5 Replace regulator 6 Have alternator repaired in a specialized shop 7 Change brushes 8 Have alternator repaired
Generator light stays lit at higher revs. 1 Conductor D + /61 grounded 2 Defective regulator 3 Defective rectifier, dirty slip rings, direct current in conductor DF or in rotor winding	1 Replace conductor or remove ground contact 2 Replace regulator 3 Have alternator repaired in a qualified shop
Generator light is lighted on engine stopped but sparkles or darkens on running engine 1 Contact resistances in charge circuit or in cable to indicator light. 2 Defective regulator 3 Defective alternator	1 Eliminate the resistance to the contact 2 Replace regulator 3 Have alternator repaired
Generator light flickers 1 Incorrect calibration in the contact type regulator or burnt out resistance of regulator.	1 Replace regulator

24.3 REGULATOR

Model - Main features	Bosch AD 1/14 N. 0.190.601.009
Test speed	4500 rpm.
Test load	13 Amp.
Adjusting voltage	13.9 - 14.8 V

24.4 RECTIFIER

Model	Bosch 14 V-22 A N. 0.197.002.003
-------	----------------------------------

24.5 STARTER MOTOR N. 0.001.157.016 (fig. 188)

Main features	Bosch DF 12 V 0.7 KW
Voltage	12 V
Output	0.7 KW
Pinion	8 teeth - mod. 2.5
Pinion rotation	counterclockwise
Brush pressure	800-900 grams
Minimum brush length	11.5 mm (.435")

a Electric tests

RUNNING	VOLTAGE V	AMPERAGE A	RPM	TORQUE kpm 3
Idle	11.5	20-40	6500-8500	
Short circuit	9	320-400	—	0.92
	8	280-360	—	0.82



Operation of relays (fig. 188/1 and 188/2)

Main purpose of a relay is to contact a high voltage with a somewhat lower one.

Since a starter motor voltage can be of several hundreds amperes, a starter motor system usually employs relays. To introduce a lower current, a mechanical switch is generally sufficient (starter button, ignition key, or riding switch).

The relay construction is exemplified in fig. 188/1. The core is in unit with the casing and on one side it projects against the inner side of the winding while on the other side it projects against the movable part of the armature relay. The core-rotor distance is the travel of the armature.

The relay casing, core, and rotor form a magnetic circuit. In many executions the relay winding consists of two winding groups: a propelling winding and a holding winding. This solution is useful in so far as thermal load is concerned. In the course of the engagement, a higher magnetic force is generated. When the start circuit closes, the propelling winding is shorted and the only force of the holding winding is sufficient to energize the relay until the start contact is opened again.

Under the action of the magnetic force generated after engagement the armature is drawn into the winding and the bridge is pushed against the contacts by the spring located between armature and bridge. The return spring assures that contacts will open. The return spring assures that the contacts will open. In addition to relays with single commutation, in starter motors are also used engaging relays in which the rotor movement is further exploited by the axial displacement of the pinion. The coupling magnet, also used on starter motor, works in the same way but does not make any commutation.

Screwing on type and translation starter motor

Construction of these motors and their internal circuits is shown in fig. 188/3-188/4-188/5.

Starter motors of this type are operated by an incorporated engaging relay.

At its jutting end, the relay armature has a groove which engages the operating lever with a predetermined clearance which is called free run. Purpose of this free run is that, on disengaging, the relay return spring pushes the armature towards the initial

188

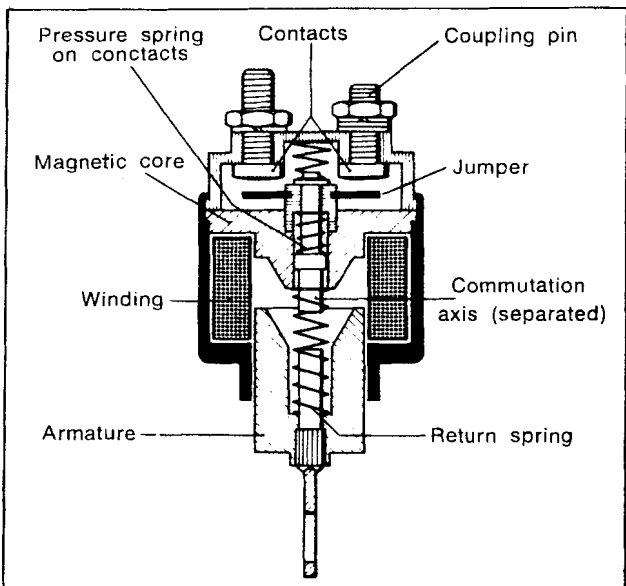

188/1

position just enough to allow such free run, thus assuring separation of the contact bridge. This is necessary when the pinion does not come out of the crown gear. (In previous models the engaging lever was rigidly connected with the relay armature with a spring for opening in the engaging device).

The armature shaft, at the pinion side, has a helical groove (fig. 188/3-188/4-188/5) in which is housed an entraining ring which is mated to the pinion by a roller type free wheel. The helical direction is such that the pinion is kept still and engages the crown wheel when the armature is rotating. The entraining ring fits two sliding guiding discs into which enter the forked lever ends.

In between the guiding disc and the entraining ring there is the so called return spring so that the engaging lever is always moving till it bottoms up and the current can also come through (this occurs when the bridge and contact close), if one of the pinion teeth is pressing against one of the crown wheel teeth.

Thus, the engaging lever pushes the entrainer and pinion forward. In addition, due to the screwing in effect in the helical groove, the pinion is pushed right in fully.

Only when the pinion is fully engaged, the helical groove allows a couple to be transmitted to the engine to be started.

The free wheel coupling provides forced interconnection between the motor armature and the engine flywheel after the engagement has occurred and disconnects as soon as the engine revs. get higher than the starter motor speed.

Engagement

The pinion-wheel coupling process occurs in two stages: translation and screwing in. This is why this type of starting device is called «translation and screwing in starter motor». However, the engagement of the starter motor really occurs in a single stage. Initially, after pressing the start button, the engaging lever moves towards a spring but does not fully activate the excitation windings and the armature. In this stage the motor does not yet revolve.

Through the pinion side guiding ring and the engaging spring, the entrainer-pinion assembly is pushed against the crown wheel and in so doing these parts start rotating due to the helical effect.

In this way, if the pinion meets a space between 2 of the crown wheel teeth (fig. 188/6), it immediately engages as deep as allowed by the engaging lever pressure or in other words until the bridge starts pushing on the relay contacts. Accordingly, the pinion has done its translation run.

If in its initial movement the pinion strikes against a tooth (fig. 188/7), then the engaging lever, through the guide ring on the pinion side, compresses the spring to such an extent as to close the contact on the bridge and the motor starts rotating. The pinion slides on the tooth head and under pressure of the preloaded helical spring and mainly because of

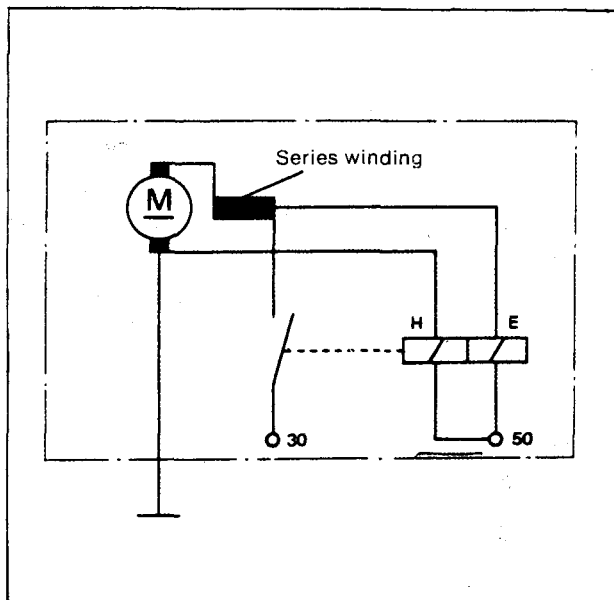

188/2

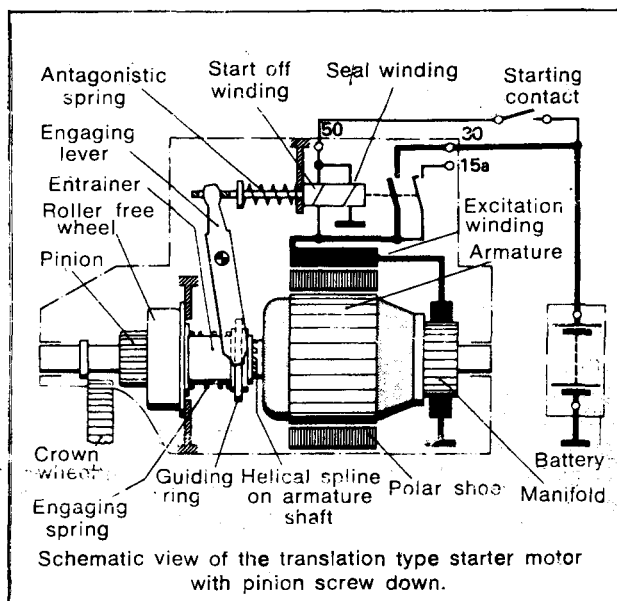

188/3

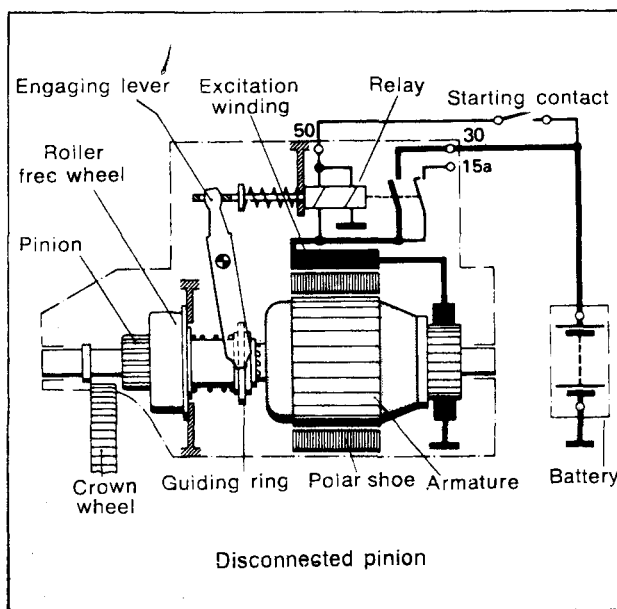

188/4

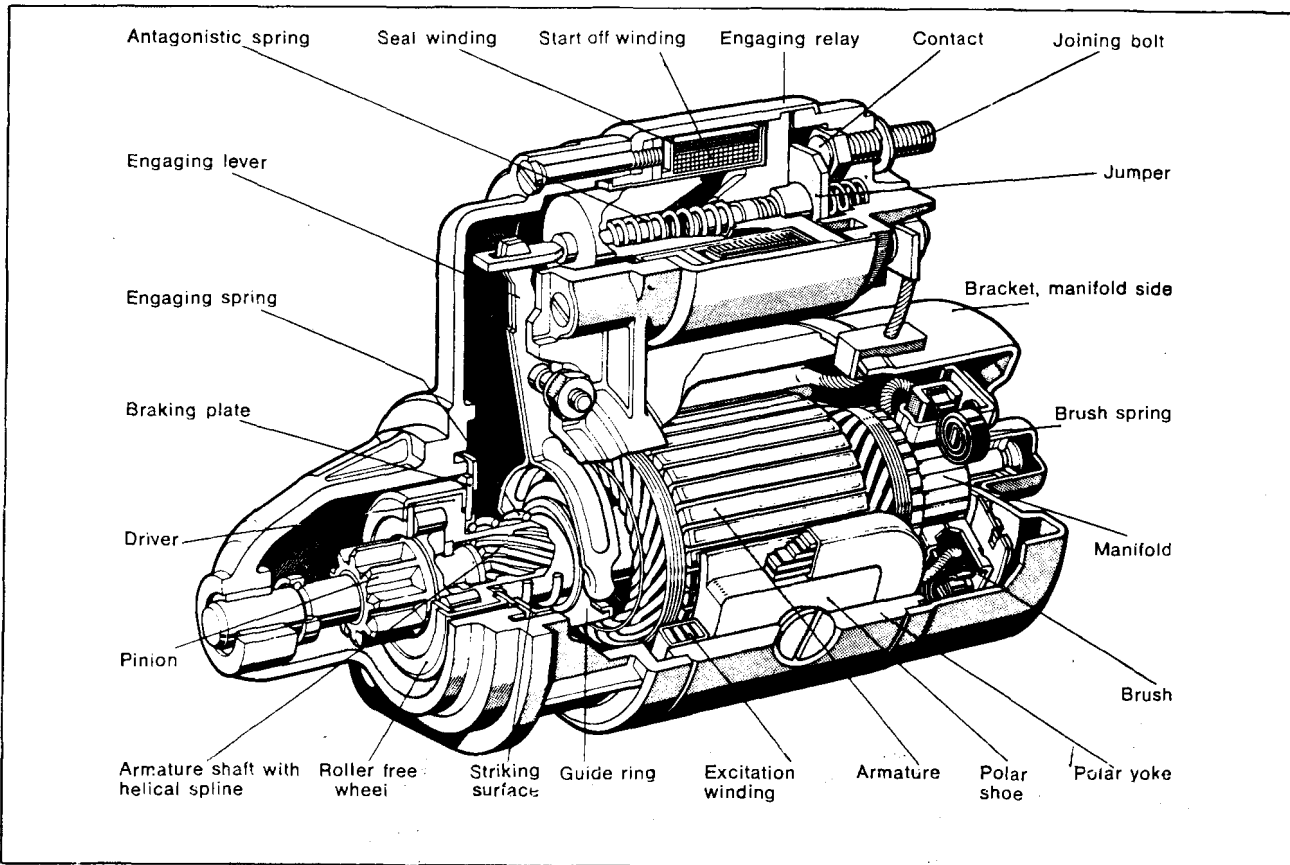

188/5

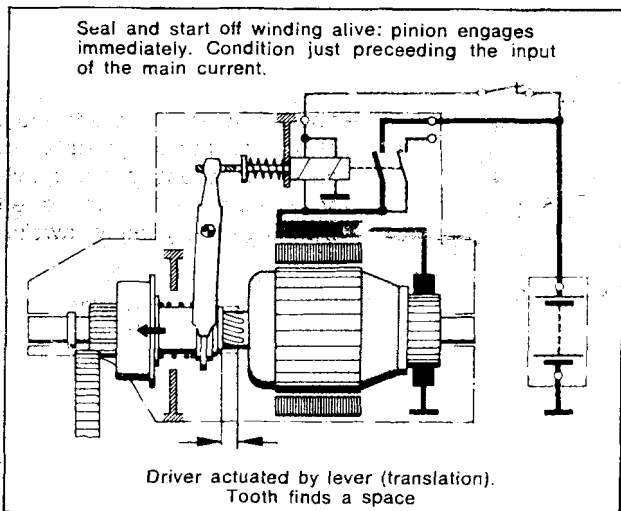

188/6

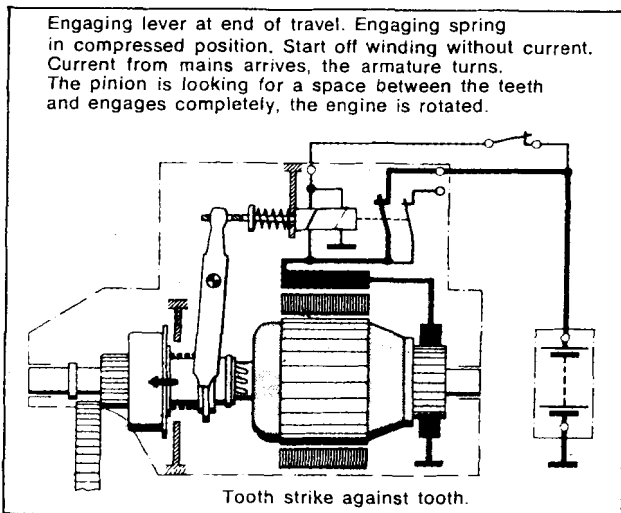

188/7

the pressure resulting from the screwing in action, engages into the space of the next teeth.

At the end of this translation movement, that is just before the complete cycle, the contacts of the engaging relay close and the starting current is inserted. The rotor is now revolving and because of the helical groove pushes the pinion (which cannot now turn) deeper into the crown wheel right against the armature spindle.

When the pinion is fully home it cannot move forward any further and is so forcibly coupled with the rotor shaft through the free wheel and the entrainer. The starter motor can now spin the engine (fig. 188/8).

Disengagement

When starting, the engine rotates faster than the starter motor, the forced pinion-armature shaft coupling is accordingly taken off the free wheel thus protecting the armature from an inadmissible number of revolutions. The pinion will stay engaged until the engaging lever stays in its engaged position.

Only when the starter button is disconnected, the coupling lever, entrainer, and the pinion return to their idle position till the next starting operation, and this irrespective of the vibrations caused by the running engine.

Free roller wheel

For safety's sake, translation type starter motors are equipped with a free wheel (188/9) to engage the pinion with the driving device (entrainer) so that when the armature shaft rotates the pinion is driven

and when the pinion turns faster, the coupling is interrupted.

To obtain this interruption, the rollers are allowed to move on a slanting track in such a way that on starting they clamp the free wheel stop ring in the narrow space with the round part of the pinion.

When the engine starts up, the rollers which are pushed by the pinion which is rotating faster than the armature, overcome the resistance offered by the springs and move over to the wider space where they can only lightly contact the free wheel restrainer and the pinion.

The springs, either directly or through bushes or guide pins, push the rollers in the rest position in the narrow section of the hollow space to allow the pinion coupling with the free wheel when the start button is pushed.

In this so called external dogs of the free wheel, the sliding sections (the dogs) are machined in the free wheel ring which turns externally and is connected to the armature shaft by the driving device (entrainer). This particular set up offers the advantage of allowing the use of a small size pinion and also the starting torque when the engine exceeds a certain number of revolutions which goes for longer life of the starter motor components and bearings.

Rotor braking

In order that the starter motor may stop quickly after the contact is interrupted and so allow, if necessary, to make a new starting attempt, the starter motor incorporates an armature brake (fig. 188/10). This is mostly made up of a mechanical brake (disc brake).

How to cure possible breakdowns

In case of any breakdown, the first thing to be considered is that the cause may not necessarily depend on the starter motor, battery, switches, electrical conductors or connections, parts not properly grounded but also to fault in the ignition or carburation systems.

The following table sums up the most common breakdowns due only to the starter motor.

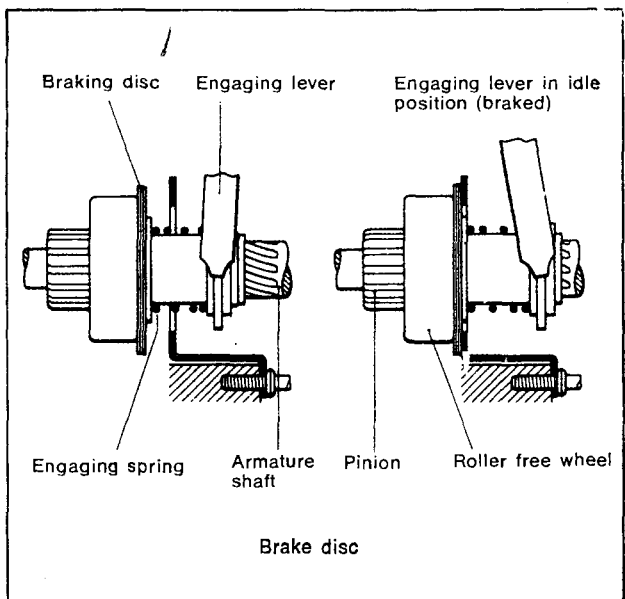
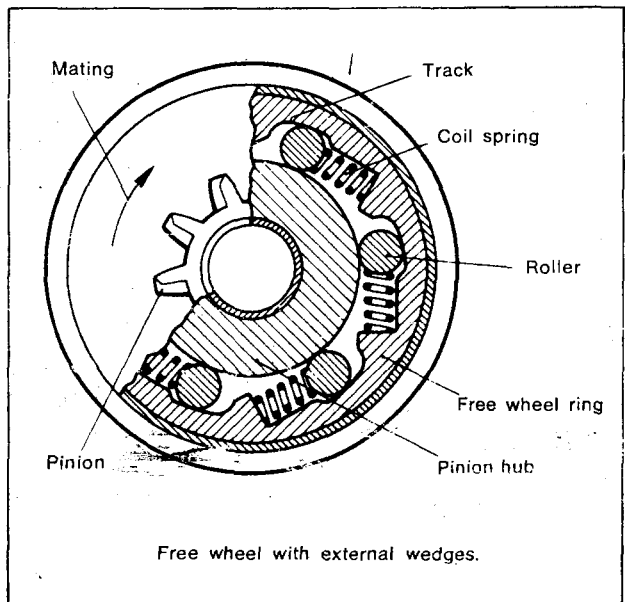
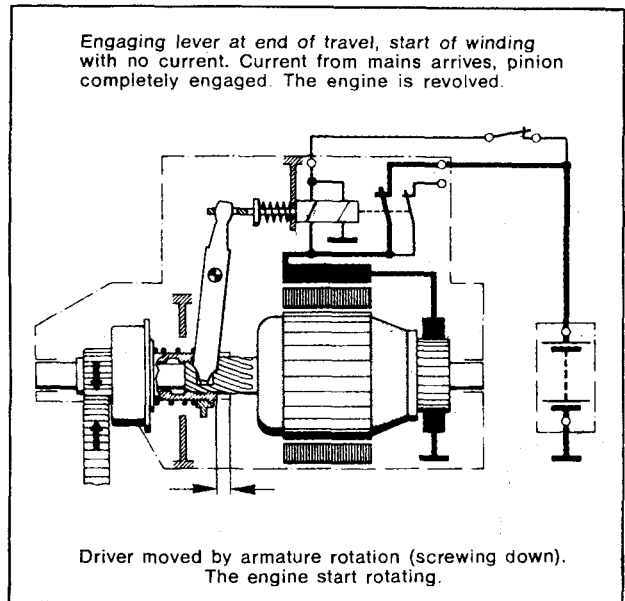

1st - On pressing the start button the motor does not turn or turns too slowly	
FAULT	REMEDY
<ol style="list-style-type: none"> 1 Discharged battery 2 Defective battery 3 Loose or oxidized battery connections 4 Grounded starter motor terminals or brushes 5 Starter motor brushes not contacting slip ring, brushes jammed in their housing, worn broken, dirty or oily brushes 6 Damaged starter motor button or relay (components so worn as to prevent the motor from starting) 7 Damaged relay 8 Excessive drop of voltage in the conductors, damaged or disconnected leads, oxidized terminals or reeds 9 Malfunction of starter motor circuits 	<ol style="list-style-type: none"> 1 Charge battery 2 Have it seen to in a qualified workshop 3 Tighten, clean or grease battery poles and/or terminals 4 Remove ground contact 5 Check brushes, clean or replace them, and eventually clean the guides or holders 6 Replace start button or relay 7 Have it repaired in a competent workshop 8 Check all conductors and connections 9 Check if all thermal cutouts are efficient and connected
2nd - The rotor turns but the pinion does not engage	
CAUSE	REMEDY
<ol style="list-style-type: none"> 1 Pinion carrier stuck 2 Pinion or crown deformed because of crashes, formation of burrs 	<ol style="list-style-type: none"> 1 Clean carrier and lightly lubricate it 2 File off burrs and/or have pinion and crown replaced in a workshop
3rd - On pressing the start button the rotor turns, the pinion engages but the engine will not start	
CAUSE	REMEDY
<ol style="list-style-type: none"> 1 Insufficiently charged battery 2 Insufficient brush pressure 3 Defective relay circuit (engaging or control relay) or other defective external relays 4 Excessive drop of current in leads 5 Sliding free wheel clutch 	<ol style="list-style-type: none"> 1 Charge battery 2 Check brushes, clean or replace as necessary 3 Have relays repaired in qualified workshop 4 Control leads and connections 5 Replace or have clutch repaired in a qualified workshop
4th - Motor continues to turn after button release	
CAUSE	REMEDY
<ol style="list-style-type: none"> 1 Starter button does not open or defective internal or external relays 	<ol style="list-style-type: none"> 1 Stop motor immediately and have button and relays checked in a workshop. Change them, if necessary
5th - The pinion does not disengage after the engine has started	
CAUSE	REMEDY
<ol style="list-style-type: none"> 1 Return spring slack or broken 	<ol style="list-style-type: none"> 1 Have starter motor repaired in a specialized workshop

24.6 IGNITION SYSTEM

Twin contact breaker (fig. 189)

Testing data:

Make	Marelli S 311 B
Rotation	Counterclockwise
Voltage	12 V
Automatic advance	31°
N. of cylinders	2
Condensers capacity «F»	0.25

Voltage test

Check dielectric rigidity by testing with A.C. at 500 V, 50 Hz for 3 seconds

Main features

Contact points gap	0.37-0.43 mm (.0014-0.016")
Contact pressure	550 gr. \pm 50
Opening angle	180° \pm 5°
Closing angle	180° \pm 5°
Timing angle between points	225° \pm 1°
Automatic advance diagram (dwg. fig. 196)	

24.7 AUTOMATIC ADVANCE

It consists of centrifugal masses suitably shaped and pivoted on the pins of the carriers in unit with the spindle.

The masses start opening at a predetermined number of revolutions. Through the special cavity in them they drag the pins on the plate in unit with the cam and cause an angular displacement of the cam itself in respect of the spindle on which the specially prolonged pin stops. Mass return is obtained by the aid of spiral springs hooked to the spindles and their rest position is also determined by the pin on reaching the slot in the plate.

At each engine speed corresponds a number of predetermined ignition control points in accordance with a curve (advance curve) which is defined in function of the engine speed itself. The advance group is incorporated in the double contact breaker.

24.8 CAPACITORS (fig. 189)

Marelli make, type CE 36 N

Connected in parallel with the breaker points, their purpose is to more abruptly cut off the current and at the same time to dampen the strong sparking effect resulting from the opening of the primary circuits.

The capacitor consists of two tin foils insulated by interposed paper strips rolled up and immersed in a special insulating liquid in an airtight container. One of the foils is connected internally to the metal cap container while the other is connected to an insulated terminal. The capacitor is part of the contact breaker unit.

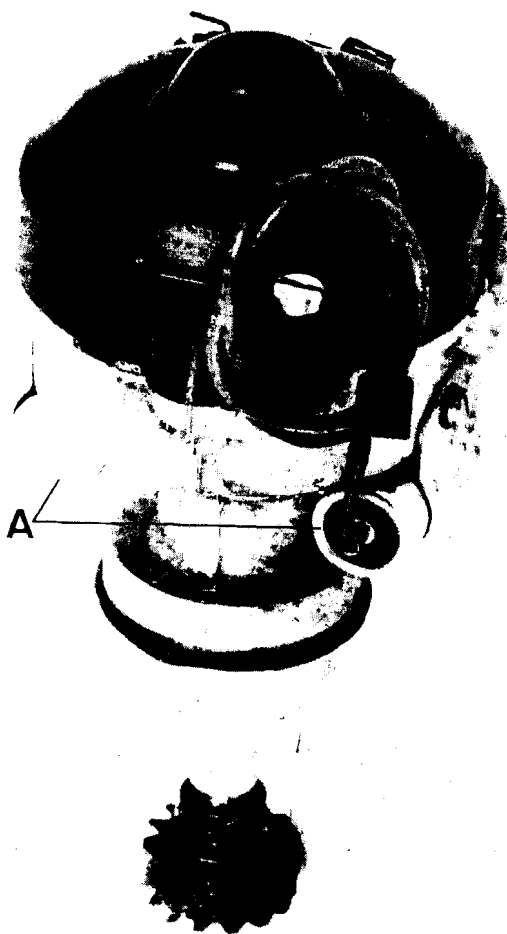

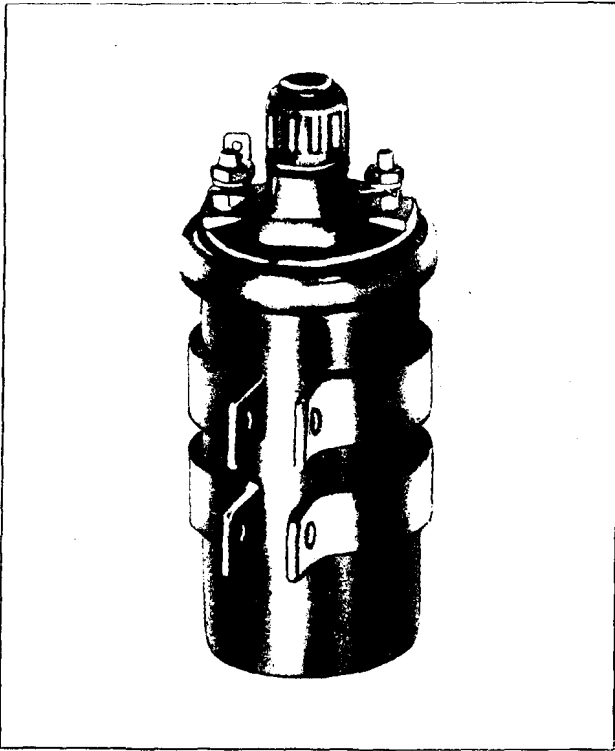

190

24.9 IGNITION COILS (fig. 190)

The Marelli BM 200 C coils consist of two windings: the primary which is formed by a few hundreds turns of fairly thick wire and the secondary by a few thousands turns of thinner gauge wire.

Testing data

Specifications

Voltage	12 V
O/D of coil	46 mm (1.77")
Employment	on motor vehicles
N. of cylinders	1 or 2

The hot engine measurement should be made after at least 2 hours operation at nominal current with distributor at 900 rpm.

Each test lasts 10 seconds during which the spark should be regular. Critical length of spark can be defined as the spark gap distance at which one starts to note no sparking.

Perforation test

At the temperature of $20^{\circ}\text{C} \pm 5^{\circ}$, ensure the coil stands up to a tension of 1000 V eff. (50 Hz) applied for 3 seconds between a primary clamp and the casing without electrical discharges.

Winding resistance at 20°C

Primary	$3.25 \Omega \pm 6\%$
Secondary	$6.200 \Omega \pm 10\%$

Coil tests

Connect up the coil as shown in the diagram, inserting in the circuit a 3 point normalized spark gap instrument as used for 4 cylinder engines (i.e. S 86 A) having a $60^{\circ} \pm 3^{\circ}$ contact closing angle.

Turning the distributor at the specified speed and feeding the coil at the current specified in the following table, the following spark plug values should be obtained.

MAIN LINE VOLTAGE VOLTS	DISTRIBUTOR SPEED rpm	CRITICAL LENGTH OF SPARK	
		COLD mm	HOT mm
8	75	8	6
12	450	10	9
12	1500	7	6

24.10 SPARK PLUGS (fig. 191)

Plug recommendation:

- AC 44 XL
- Bosch W 225 T2
- Champion N 9 Y
- Lodge HLNY
- Marelli CW 7 LP

Spark points gap: 0.6 mm (.023").

Spark plugs are best cleaned with petrol and a wire brush and a needle for the inner part.

In re-fitting, be sure they are properly started by hand for a few turns, completing the operation by means of the plug wrench in the tool kit.

For all events, the plugs should be changed every 10.000 km (6000 miles) even if they still appear to be in good condition.

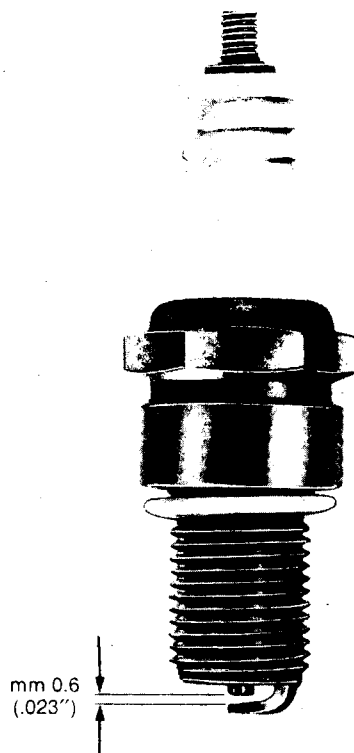

191

24.11 ASSEMBLING THE TWIN BREAKER (fig. 192)

After adjusting the points as described in para. 6.11, the contact breaker is re-fitted on the crankcase as follows:

- Rotate the crank shaft until fixed advance mark «2» (just before letter «D» on the flywheel) is in line with mark «1» on the inspection hole rim «A» (this indicates that the R/H cylinder piston is advanced 2° as compared to the TDC with both valves closed)
- Turn the contact breaker shaft clockwise to the point where the camshaft starts to open the contact points of the R/H cylinder (red cable). At this stage in the hole introduce the gear and engage it with the worm gear on the camshaft. After this, before proceeding with timing the ignition, provisionally fit up the breaker retaining plate to the crankcase, without tightening the screws, and make sure that the contact breaker top is positioned as shown in the picture 192/1. This to make assembly of the frame unit much easier.

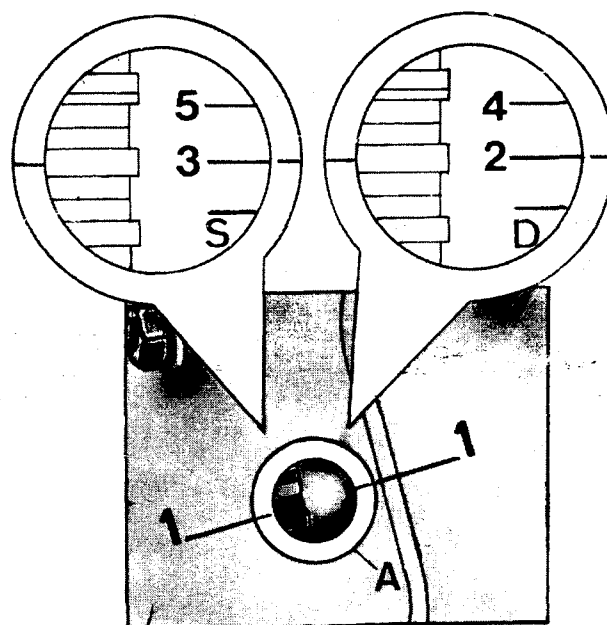

192

24.12 IGNITION TIMING (FIXED ADVANCE) FOR THE R/H CYLINDER (red cable, fig. 194)

After adjusting the breaker points to 14-16" (see para. 6.11) time the ignition as follows:

- 1 In the R/H cylinder plug hole, fit stand 17 94 82 60 (26 in fig. 35) with gauge (see fig. 193).
- 2 Flatten the lockplate ear and undo the drive pinion locking.
- 3 In the crankshaft groove fit up timing plate holder 17 94 96 60 (25 in fig. 194) and secure it with a screw. On this set up the degree plate part N. 19 92 74 00 (2 in fig. 194).
- 4 Secure indexing arrow 17 94 75 60 (3 in fig. 194) in the crankcase but do not tighten completely.
- 5 Turn the crankshaft till the gauge dial shows TDC for the R/H cylinder (valve closed).
- 6 Zero set the gauge and line up the indexing arrow with the degree plate zero. Tighten the securing screw.

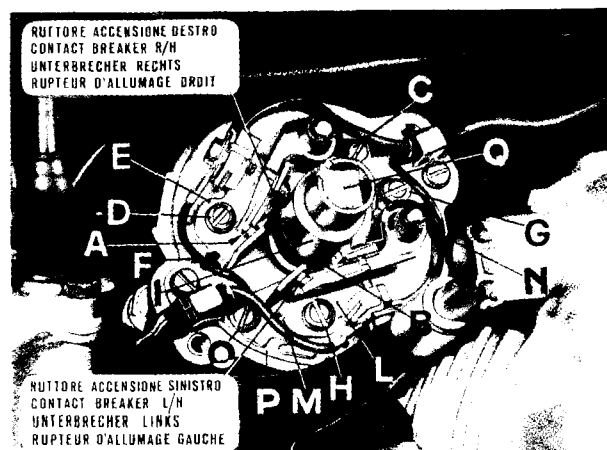

192/1

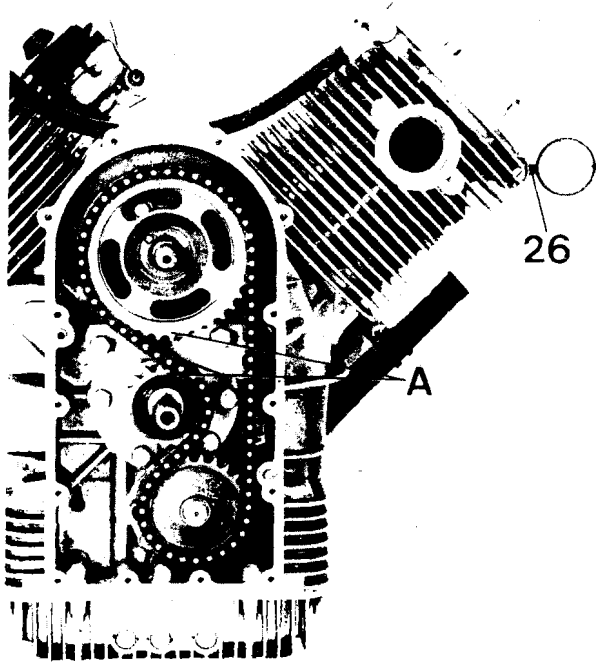

193

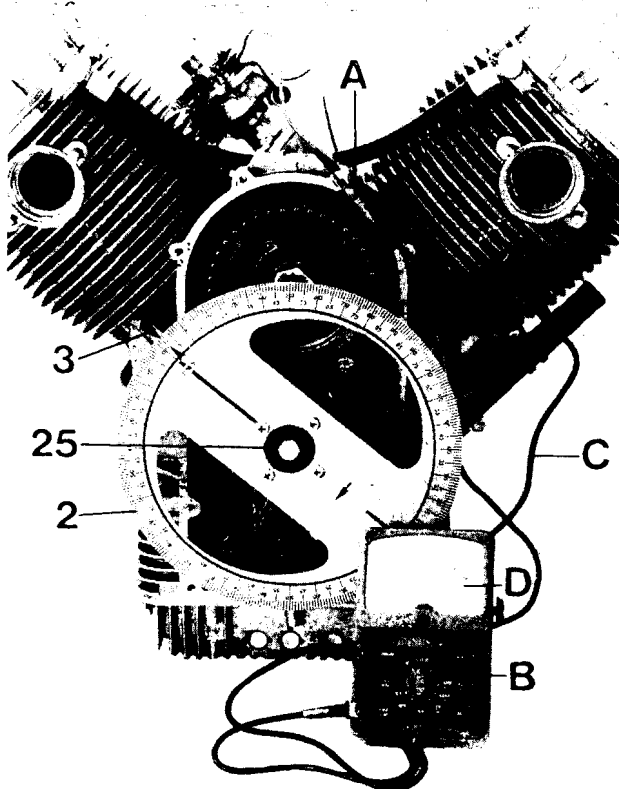

194

138

7 To the feed clamp «A» of tester «B» connect the red cable of the breaker and the ground terminal «C» to one of the crankcase fins.

8 Turn the degree plate counterclockwise and then clockwise till needle «D» of tester «B» starts moving. At this stage, check that the degree plate is at 2° before TDC in regard to the indexing arrow.

9 If the tester needle does not move exactly to the predetermined position, loosen the breaker securing screws to crankcase using special spanner N. 14 92 70 00 (13 in fig. 35) and rotate the breaker unit to the right or left until needle «D» of tester «B» starts its movement towards the predetermined position.

L/H cylinder (green cable - fig. 195)

The instruction at points 2-3-6-8 for the R/H cylinder also apply for the L/H cylinder (green cable). For the other points proceed as follows:

1 Fit stand 17 94 82 60 in the L/H cylinder plug hole (26 in fig. 193).

4 On the L/H side of the crankcase set up index 17 94 75 60 (3 in fig. 195) without tightening its securing screw.

5 Turn the crankshaft till the gauge dial shows TDC for the L/H cylinder (valve closed) and marks «A» on timing gears are in line with each other (fig. 193).

7 Secure the breaker cable (green) to feed clamp «A» of tester «B».

9 If the tester needle does not move to the predetermined position, it is necessary to slacken screws «N» and «O» (fig. 192/1) and with a screwdriver in groove «M», shift plate «P» to the right or left till the needle starts moving towards the predetermined point «O». Repeat this operation till the contacts opening, and the phase angle is within the predetermined limits. At the end of this operation, tighten screws «N» and «O» (fig. 192/1) and disconnect the tester clamps from the green cable and the crankcase fin.

10 Remove the stand-gauge assembly.

Remove degree plate and indexing arrow.

Tighten the drive pinion locking and secure it by flattening an ear of the lockplate against one of the locking grooves.

Fit rocker covers with gaskets.

Fit spark plugs.

Fit timing cover with gasket.

Insert the complete rotor-stator unit (securing the stator to the cover as shown in fig. 180 and securing the rotor to the crankshaft with its Allen screw).

11 Fit provisionally the generator cover as well.

24.13 CHECKING THE IGNITION ADVANCE (STATIC + DYNAMIC) USING A STROBE LAMP (fig. 196, 197, and 198)

Right cylinder (fig. 197)

Check the ignition advance for this cylinder as follows:

1 Remove the rubber cap from the inspection hole «C» which is mounted on the gearbox, right side.

- 2 Raise the saddle and keep it lifted up with its rod. Remove tool box (fig. 178).
- 3 Connect cable «A» of strobe lamp «B» to the plug lead on the R/H cylinder head.
- 4 Connect both strobe lamp cables with clamps: clamp + to battery terminal + clamp - to battery terminal -
- 5 Start the engine, run it up to its normal operating temperature, and direct the strobe light beam on control hole «A», and check that the static advance mark «2» is in line with the mark in the middle of the inspection hole rim at an engine speed of about 900 rpm. and the full advance mark «4» (static dynamic) is aligned with the mark on the inspection hole rim at 6000-6200 rpm. (fig. 192).

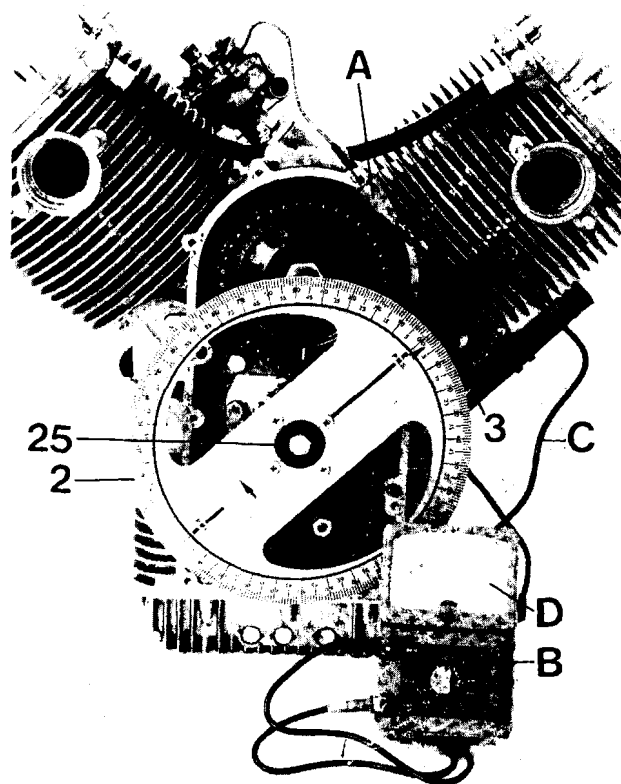

Left cylinder (fig. 198)

Points 1-2-4 in the previous chapter for the right cylinder still apply. Points 3 and 5 are changed as follows:

- 3 Connect strobe lamp cable «A» to the spark plug lead for the L/H cylinder.
- 5 If the static advance mark «3» and full advance mark «5» are in line with mark «A» on the inspection hole rim for both cylinders at the stated engine speeds, this means that all is in order (see fig. 192).

Ignition data

Ignition advance (static)	2°
Automatic advance (dynamic)	31°
Total advance	33°
Breaker points gap	0.37-0.43 mm (.014-.017")
Plug points gap	0.6 mm (.023")

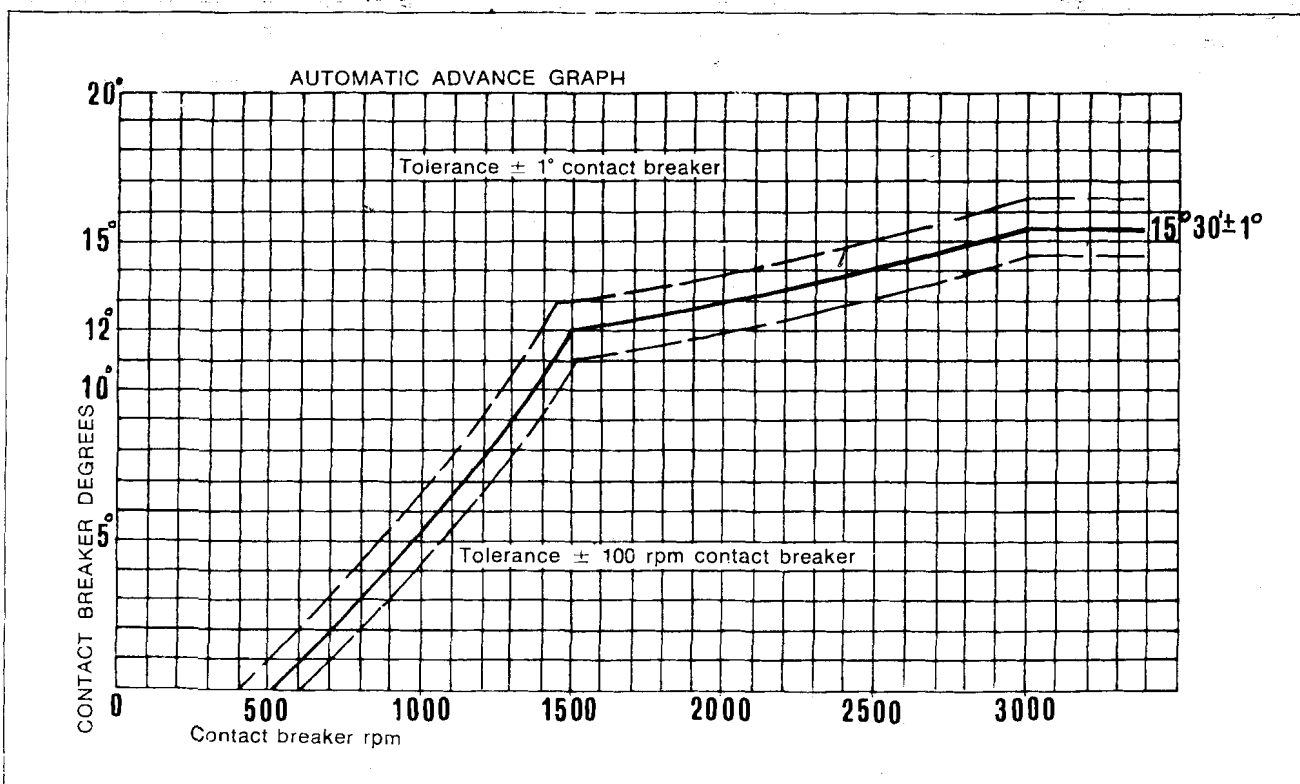

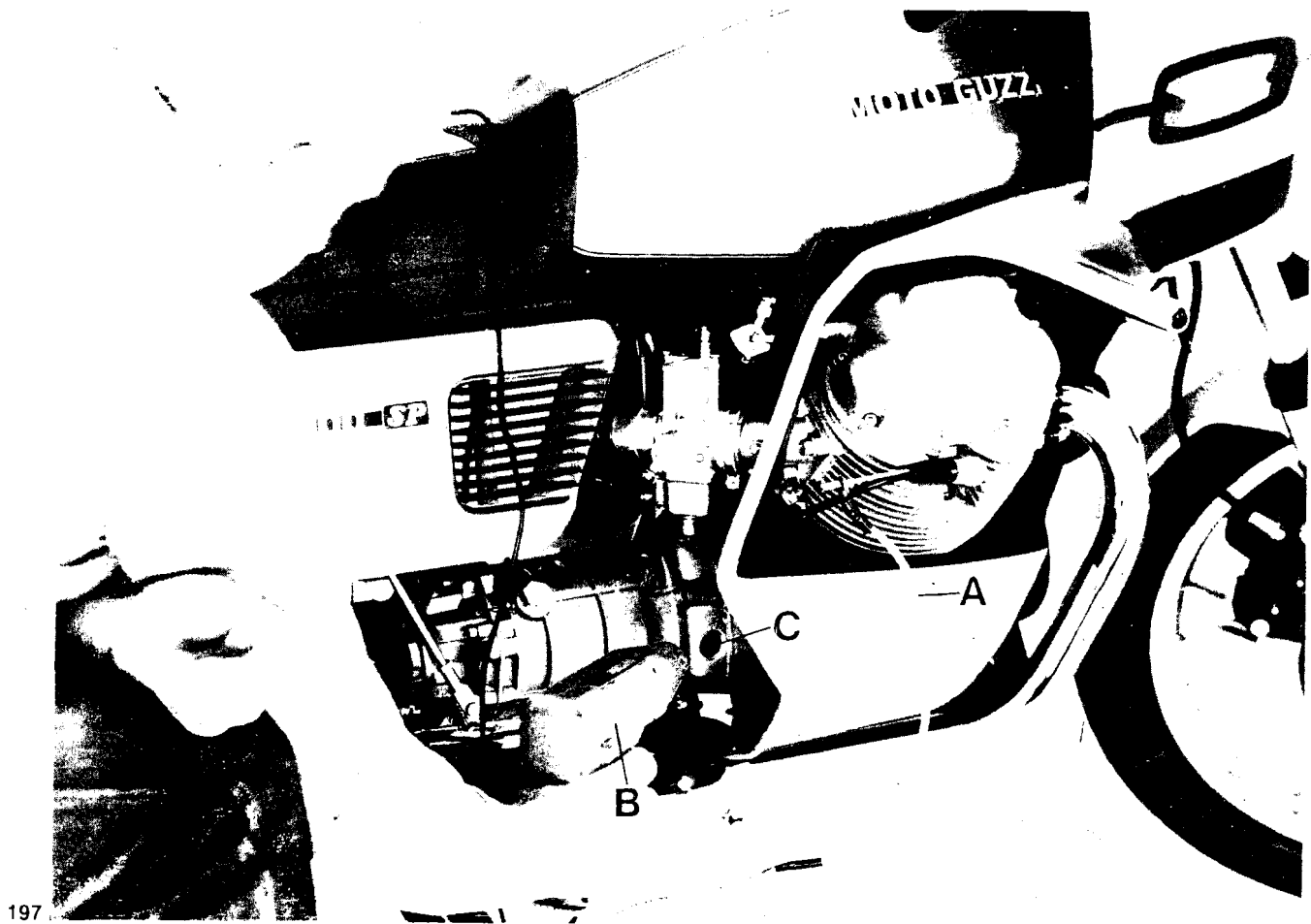

197

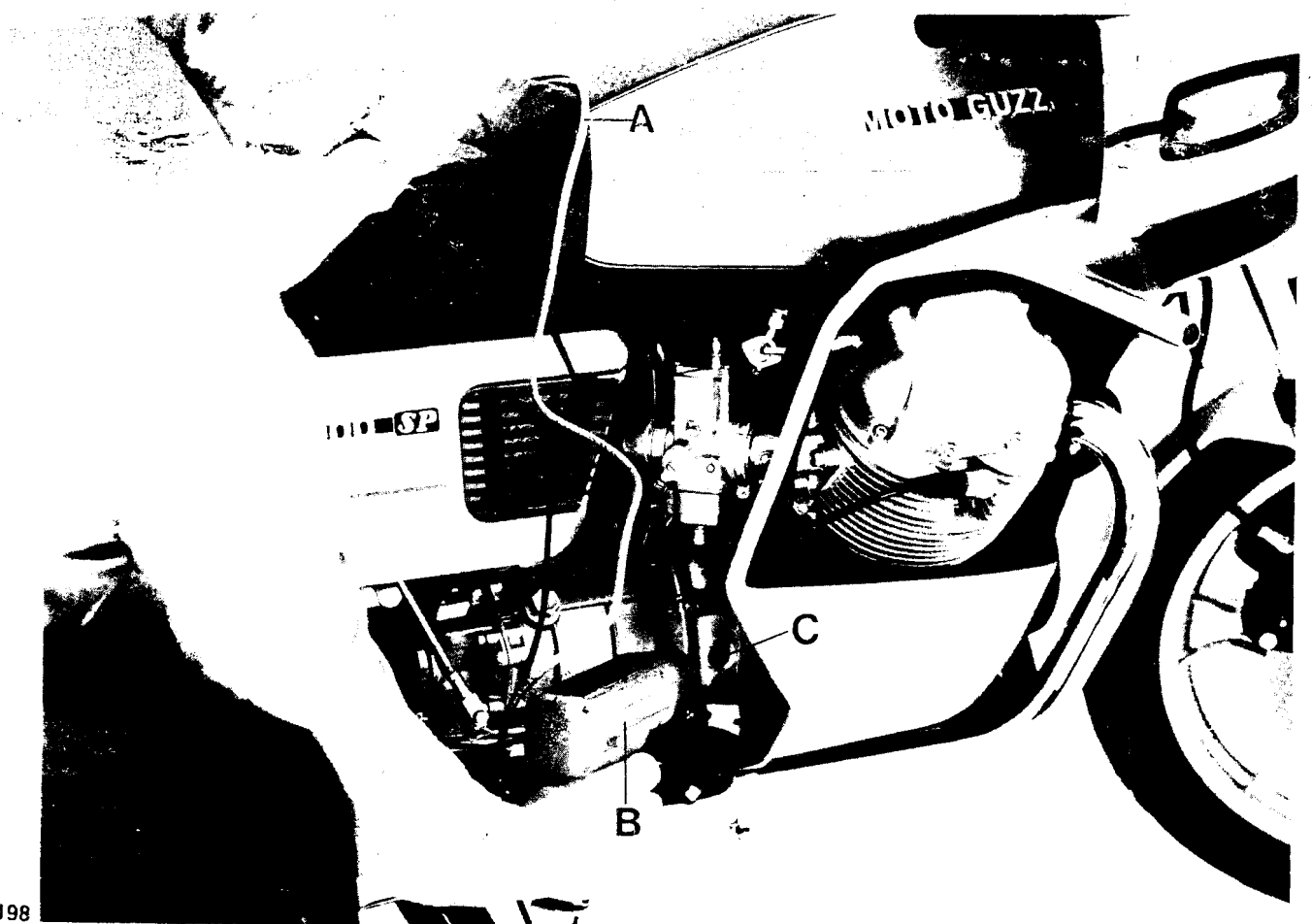

198

24.14 LIGHTING EQUIPMENT AND HORN - V 1000 G 5

a Bulb replacement

Headlight (fig. 199)

Loosen bottom screw «B», disconnect headlight insert and replace the bulb.

b Tail light (fig. 200)

Undo screws «D» securing the reflector to the tail light housing, press the bulb inwards and twist it at the same time to take it out.

c Turn signals (fig. 200)

Loosen screws «E» securing the reflectors to the signal light housing, press the bulb in and twist it at the same time to take it out.

d Number plate light (fig. 200)

Loosen screws «F» securing the transparent part to the housing. Press the bulb inwards and twist it at the same time to take it out.

Caution - When re-fitting the reflectors onto the tail light, number plate light, and turn signal lights, do not screw in too tightly to avoid breaking the reflector.

e Instrument panel, tachometer, and rev-counter

Take out bulb holders from panel, tachometer, or rev-counter, and remove the bulbs.

f Bulbs (12 V)

Headlight

- high and low beam 45/40 W;
- town driving or parking 4 W;

Tail light

- parking and stop light 5/21 W;
- number plate light 5 W;

Turn signals 21 W;

Panel warning lights 1.2 W;

Tachometer and rev-counter light 3 W.

g Electric horns

The horns circuit includes:

- high pitched tone horn;
- low pitched tone horn;
- ground on frame.

Horn features

Combined horn, Belli make.

High pitched horn (90/12/2), absorption 3 A.

Low pitched horn (90/12/4), absorption 4 A.

Total combined absorption: 7 A.

24.15 LIGHTING EQUIPMENT AND HORN - 1000 SP

a Bulb replacement

Headlight (fig. 201)

Undo bottom screw «D», remove both bulb holders, and replace bulbs.

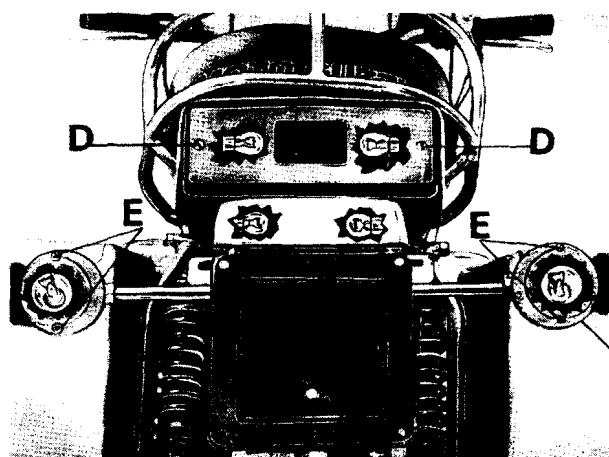
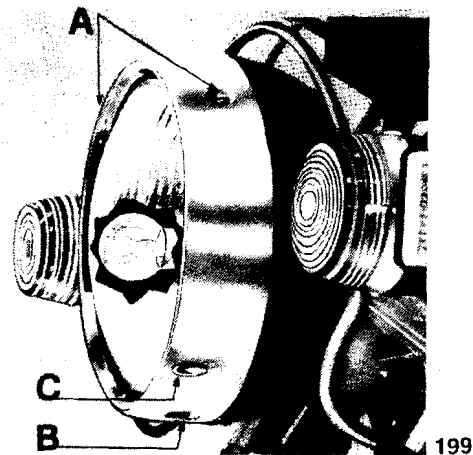

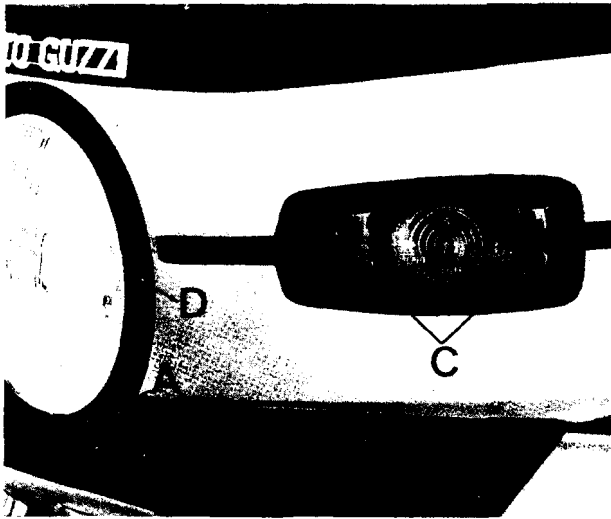

b Front turn signals (fig. 202)

Loosen screws «C» securing the reflectors to the housing. Push in the bulb and twist it at the same time to remove it from the holder.

c Tail light (fig. 202)

Loosen screws «A» securing the reflector to the tail light housing, press the bulb inwards and twist it at the same time to remove it.

d Rear turn signals (fig. 202)

Undo screws «B» securing the reflector to the housing, push the bulb inwards turning it at the same time to take it out.

Caution - When re-fitting the reflectors, do not screw in too tightly to avoid breakages.

e Tachometer/speedometer, rev-counter, voltmeter, clock, panel

Take out bulb holders, and remove the bulbs.

f Bulbs

Headlight:

- high and low beam 45/40 W;
- town driving or parking light 4 W.

Tail lamp:

- Parking and stop light 5/21 W.
- Turn signals: 21 W.
- Panel indicators: 1.2 W.
- Tachometer and rev-counter: 3 W.
- Voltmeter: 3 W.
- Clock: 3 W.

g Electric horns

The horns circuit includes:

- high pitched tone horn;
- low pitched tone horn;
- ground on frame.

Horn features

Combined horn, Belli make.

High pitched horn (90/12/2), absorption 3 A.

Low pitched horn (90/12/4), absorption 4 A.

Total combined absorption: 7 A.

Overhaul and repair instructions

If one of the horns loses its tone or fails altogether, check if this is not due to some fault in the electric system.

If the horn does not work, ensure the pushbutton is not faulty or any wire is disconnected in the terminal block.

If the horns give an irregular sound, check if the securing bolt is well tight.

If the horn sounds uninterruptedly, inspect the ground-contact between button and horns.

Should these inspections fail to determine the trouble, the fault lies obviously in the horns themselves and they should be repaired or replaced by a specialized workshop.

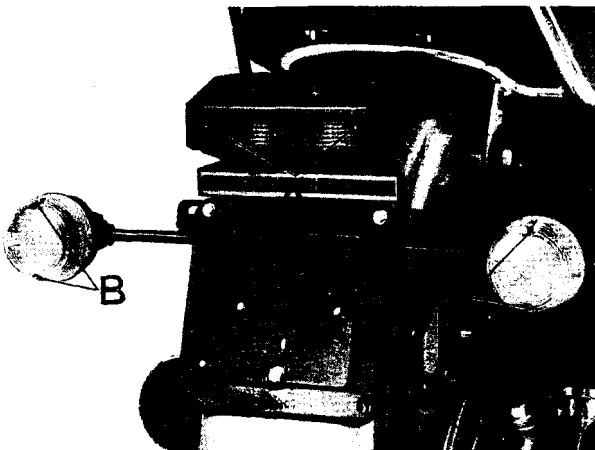

201

202

25.2 1000 SP (fig. 204) - LEGEND

- 1 Tachometer (bulb 3 W)
- 2 Rev-counter (bulb 3 W)
- 3 High beam warning light (1.2 W)
- 4 Oil pressure warning light (1.2 W)
- 5 Neutral position warning light (1.2 W)
- 6 Parking light indicator 1.2 W)
- 7 Generator charge warning light (1.2 W)
- 8 Low beam (40 W)
- 9 High beam (45 W)
- 10 Turn signal indicator, front, right (21 W)
- 11 Turn signal indicator, front, left (21 W)
- 12 Engine starting and stopping device
- 13 Control: turn indicator lights, horns, flashing light
- 15 Horns (absorption 7 A)
- 16 Front brake switch
- 17 Flashing light relay (flash)
- 18 Rear brake switch
- 19 Battery
- 20 Regulator
- 21 Rectifier
- 22 Alternator
- 23 Starter motor relay
- 24 Starter motor
- 25 Turn indicator light, rear left (21 W)
- 26 Rear stop light (21 W + 21 W)
- 27 Number plate light (5 W + 5 W)
- 28 Turn indicator light, rear, right (21 W)
- 29 Turn indicator lights, flasher unit
- 30 Oil pressure switch
- 31 Neutral position cutout
- 32 Terminal block with fuses (16 A fuses)
- 33 Contact breaker
- 34 Coils
- 35 Ignition switch (3 positions)
- 36 Spark plugs
- 37 Parking light, front (4 W)
- 38 Brake fluid level warning light (1.2 W)
- 39 Brake fluid level indicator
- 40 Turn signal lights bracket
- 41 Voltmeter (3 W)
- 42 Clock (3 W)
- 43 Turn light warning light (1.2 W), left
- 44 Turn light warning light (1.2 W), right
- 45 4-way connector
- 46 3-way connector
- 47 Switch, simultaneous flashing lights

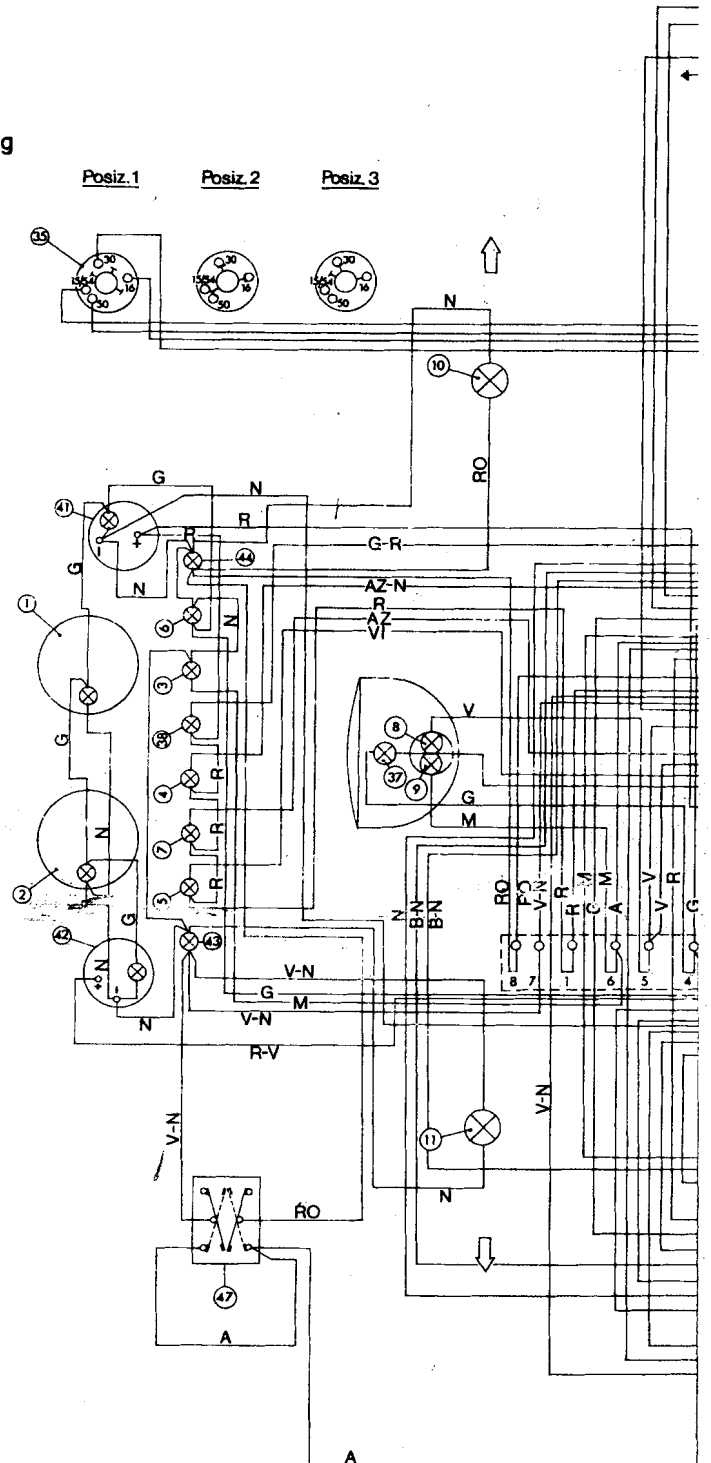

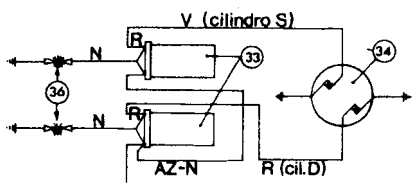
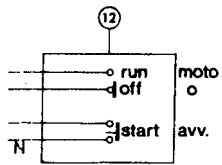

- BI = White
- N = Black
- G = Yellow
- V = Green
- R = Red
- B = Blue
- VI = Violet
- RO = Pink
- A = Orange
- M = Brown
- BI-N = White-Black
- GR = Grey
- AZ = Sky blue
- B-N = Blue-Black
- V-N = Green-Black
- R-N = Red-Black
- AZ-N = Sky blue-Black

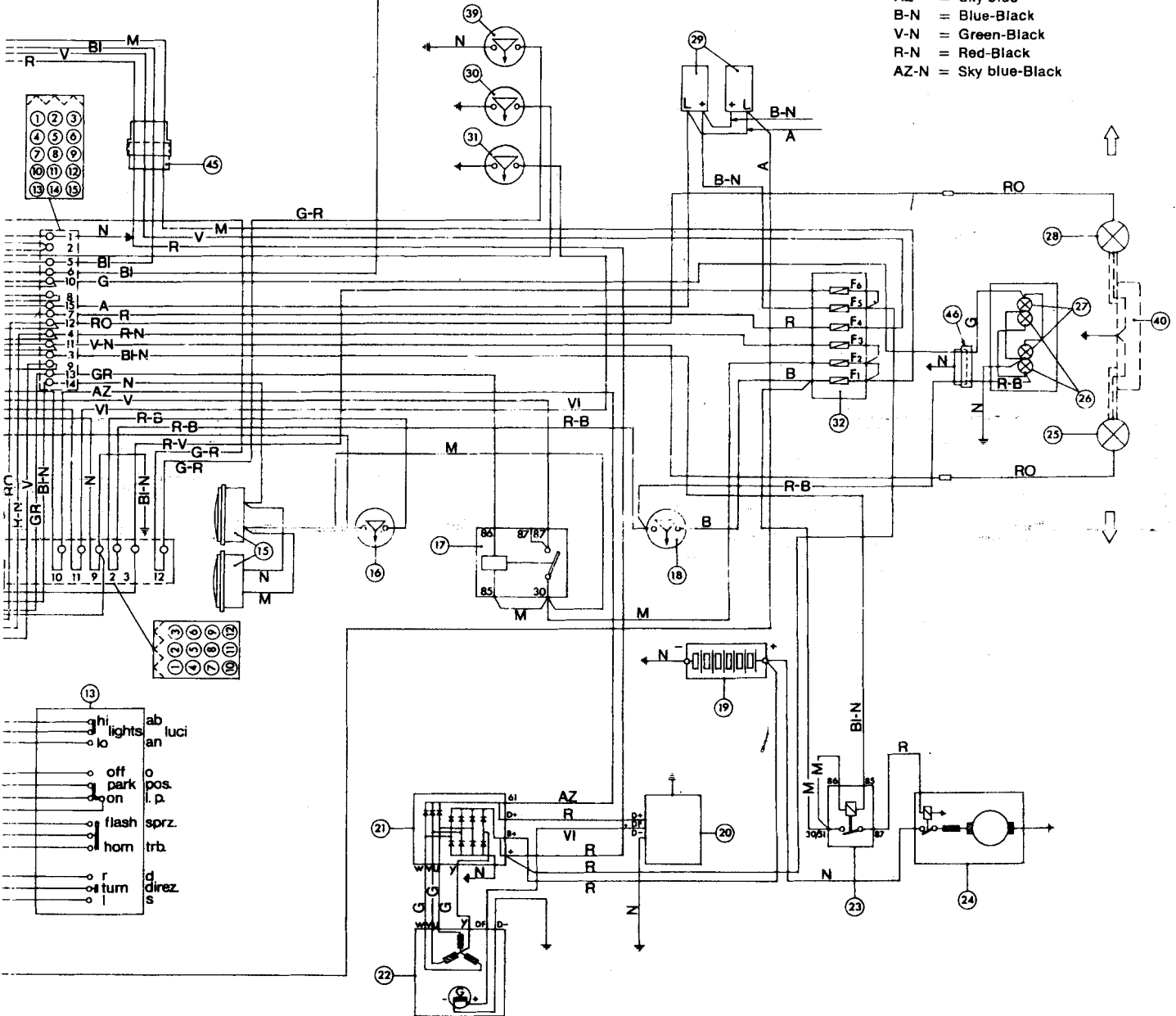



850 Le Mans
II

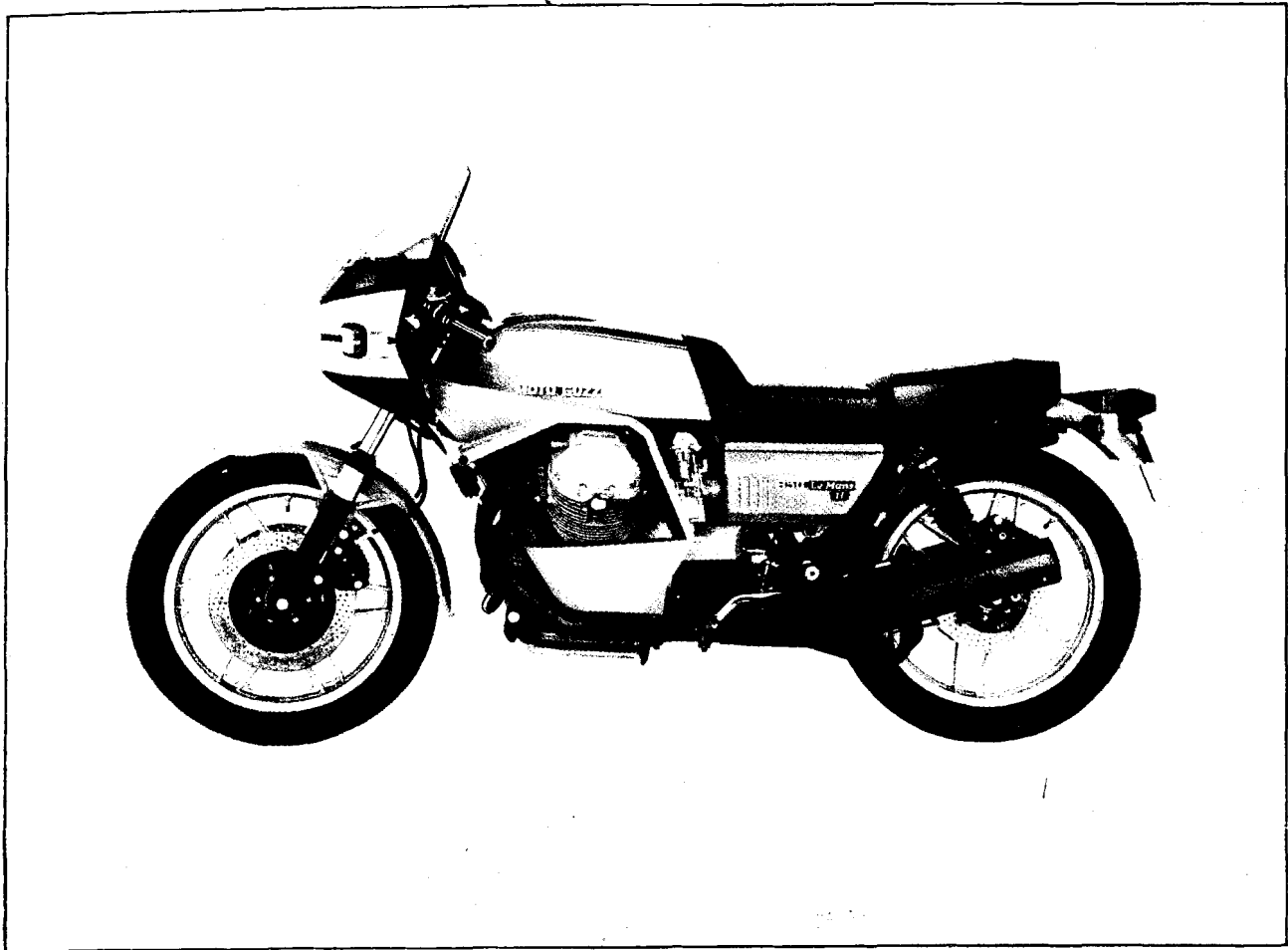

HINTS ON THE PROPER USE OF THIS MOTORCYCLE

Due to its exceptionally high feature, this motorcycle can be considered as in the racing machine class and as such has to be ridden in a sportsmanlike way.

For this very reason, it has met the favour of many motorcycle fans but, same as for all racing bykes, it has to be used accordingly.

For instance, for fuel feed this model is fitted with carburettors with pumps and if the twist grip is not used correctly in accordance with the engine revolutions, there might be an excess of fuel which is ejected by the carburettors, similarly as occurs on sporting cars that fit same type carburettors.

It is obvious that if in such conditions the engine backfires, the risk of a fire is quite considerable. When travelling at low speed or in other words at low revs, it is necessary for the throttle grip to be used with care since the immission of a greater quantity of fuel might not be fully absorbed by the engine.

At high speed, also in case of abrupt accelerations, the fuel is entirely absorbed and used up by the engine, thus eliminating this risk and conferring to this model the brilliant «kicking up» qualities that make it one of its outstanding features.

INDEX

25 MAIN FEATURES pag. 151

26 CONTROLS AND ACCESSORIES pag. 153

27 INSTRUMENTS AND CONTROLS pag. 154

- 27.1 Panel board
- 27.2 Light switches
- 27.3 Horn flashing light and turn signal controls
- 27.4 Engine starting and stopping buttons
- 27.5 Fuel filler cap
- 27.6 Saddle lifting device

28 CYLINDERS - PISTONS - PISTON RINGS pag. 156

- 28.1 Cylinders
- 28.2 Pistons
- 28.3 Fitting the piston on con-rod
- 28.4 Piston pin - piston hole - clearances

29 CON-RODS - CRANKSHAFT pag. 158

- 29.1 Connecting rods
- 29.2 Crankshaft

30**CARBURATION**

pag. 160

- 30.1 Carburetors
- 30.2 Floats levelling
- 30.3 Adjusting idling speed without vacuumeter
- 30.4 Checking the carburation with a vacuumeter
- 30.5 Carburettor components

31**REAR SUSPENSION**

pag. 164

32**FRONT SUSPENSION AND STEERING**

pag. 164

33**WHEELS**

pag. 164

34**ELECTRICAL EQUIPMENT**

pag. 164

- 34.1 Battery
- 34.2 Spark plug recommendations
- 34.3 Ignition timing "fixed advance"
- 34.4 Checking ignition advance (fixed + automatic) using a strobe light
- 34.5 Ignition data

35**HORN AND LIGHTING EQUIPMENT**

pag. 165

- 35.1 Replacing the lamps
- 35.2 Lamps
- 35.3 Headlight beam adjustment

36**ELECTRICAL EQUIPMENT**

pag. 166

- 36.1 With unprinted panel circuit
- 36.2 With printed panel circuit

37**CONVERSION KITS AVAILABLE ON REQUEST**

pag. 168

- 37.1 Table of the gears and main shafts set for straight toothed gearbox
- 37.2 Engine boostup kit

25 MAIN FEATURES

ENGINE	4-stroke
— cylinder disposition	«V» type 90°
— bore	83 mm
— stroke	78 mm
— displacement	844 cc
— compression ratio	10.2
— max torque	7.8 kgm at 6600 rpm
VALVE GEAR	OHV push rod operated
CARBURATION	2 «Dell'Orto» carburetors PHF 36 B(D) (right) PHF 36 B(S) (left)
LUBRICATION	oil pressure by gear pump wire gauze and cartridge filters in the oil sump oil pressure 3.8-4.2 kg/cm ² (54-60 lbs. sq.in), controlled by relief valve in the sump oil pressure solenoid
GENERATOR ALTERNATOR	located at the front end of the crankshaft (14 V - 20 A)
IGNITION	battery-coil with twin contact breaker
— ignition data	initial advance (fixed) 8° automatic advance 26° total advance 34°
— contact breaker points gap	0.37 ÷ 0.43 mm (.014-.017")
— spark plug type	Bosch W 230 T 30 Champion N 9 Y Lodge 2 HLN Y
— spark plug points gap	0.5 mm (.019")
— ignition coils	2 fitted on the frame over the engine unit
STARTING	electric starter (12 V - 0.7 KW) with electromagnetic ratchet control ring gear secured to flywheel starter button (START) on the R/H side of the handlebar
TRANSMISSION	
CLUTCH	dry type - 2 driven plates on the flywheel lever controlled from the handlebar (left)
PRIMARY DRIVE	by gears, ratio 1 : 1.235 (Z = 17/21)
GEARBOX	5 speeds frontal engagement, constant mesh gears cush drive incorporated foot controlled on the L/H side of the vehicle
— ratios:	
low gear	1 to 2 (14/28)
2nd gear	1 to 1.388 (18/25)
3rd gear	1 to 1.047 (21/22)
4th gear	1 to 0.869 (23/20)
high gear	1 to 0.750 (28/21)

SECONDARY DRIVE	cardan shaft and level gear set
— ratio	1 to 4.714 (7/33)
— overall gear ratios:	
low gear	1 to 11.643
2nd gear	1 to 8.080
3rd gear	1 to 6.095
4th gear	1 to 5.059
high gear	1 to 4.366
FRAME	
SUSPENSION	cradle type - tubular structure
— front	telescopic front fork «MOTO GUZZI patent»
— rear	swinging arm with externally adjustable springs
WHEELS	rims cast in light alloy, rim size
— front	WM 3/2.15 × 18"
— rear	WM 3/2.15 × 18"
TIRES	
— front	Pirelli 100/90 H 18 (MT 18) Michelin 3.50 H 18 (M 45) Metzeler 3.50 H 18 (Rille)
— rear	Pirelli 110/90 H 18 (MT 18) Michelin 4.00 H 18 (M 45) Metzeler 4.10 V 18 (Block C7)
	<i>Tire brand fitted alternatively to comply with the different standards in each country.</i>
BRAKES	
— front	hydraulic disc - twin braking cylinders caliper - hand controlled from the R/H side handlebar hydraulic circuit independent from rear brake: disc dia. 300 mm (11.8") braking cylinder dia. 38 mm (1.49") master cylinder dia. 12.7 mm (.5")
— rear	hydraulic disc - twin cylinder caliper foot controlled on the R/H side of the vehicle: disc dia. 242 mm (9.5") braking cylinder dia. 38 mm (1.496") master cylinder dia. 15.875 mm (.6249") the rear brake is hydraulically interconnected to a second front brake featured and dimensioned same as the R/H lever controlled brake
OVERALL DIMENSIONS AND WEIGHTS	
— wheel base	1.485 m (58.4")
— length	2.190 m (86")
— width	0.610 m (24")
— height	1.210 m (47")
— ground clearance	0.175 m (6.9")
— dry weight	196 kg (431 lbs)
PERFORMANCES	
— max speed	solo riding: 230 km/h (144 mph)
— fuel consumption	6.5 lts km (abt 32 mpg)
FUEL AND OIL CAPACITIES	
— fuel tank	22.5 lts (5.84 us gls) Petrol Super (98/100 NO-RM)
— reserve oil sump	3 lts (3 ¹ / ₄ quarts) «Agip SINT 2000 SAE 10 W/50»
— gearbox	0.750 lts (1,3/4 pints) «Agip F.1 Rotra MP SAE 90»
— rear drive box (level gears)	0.250 lts (abt 9 oz) of which: 0.230 lts (8 ¹ / ₄ oz) «Agip F.1 Rotra MP SAE 90» 0.020 lts (3/4 oz) «Agip Rocol ASO/R» (Molikote type «A»)
telescopic fork (each leg)	0.090 lts (3 oz) «Agip F.1 ATF Dexron»
— front and rear braking circuits	«Agip F.1 Brake Fluid - SAE J 1703 B»

26 CONTROLS AND ACCESSORIES

(fig. 206)

- 1 Front turn signal lights.
- 2 Control lever, R/H front brake.
- 3 Voltmeter.
- 4 Speedometer.
- 5 Throttle control grip.
- 6 Ignition key.
- 7 Fuel tank lock set.
- 8 Left front brake and rear brake pedal.
- 9 Front foot-rest.
- 10 Master cylinder for left front and rear brake.
- 11 Saddle lifting lever.
- 12 Rear foot-rest.
- 13 Headlight.
- 14 Panel board.
- 15 Rev-counter.
- 16 Clutch lever.
- 17 Clock.
- 18 Gear selector pedal.
- 19 Rear turn light.
- 20 Tail light.

Right or left in the text is as seen by the rider astride the saddle.

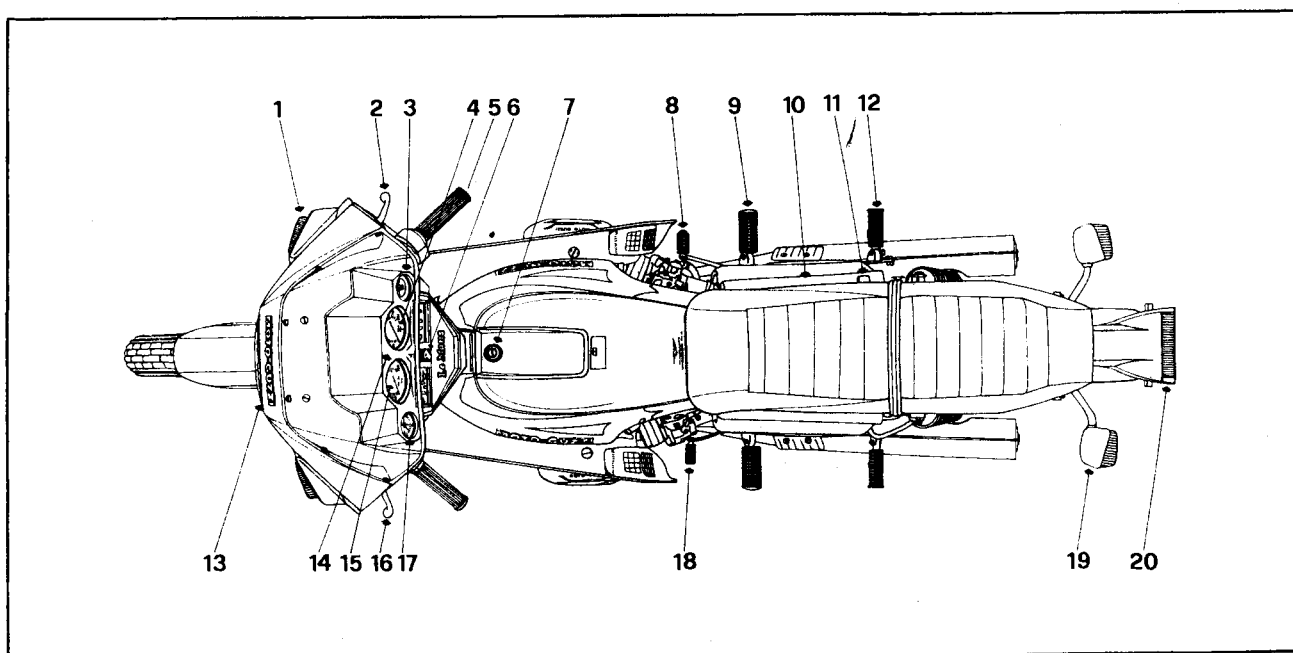

206

27 INSTRUMENTS AND CONTROLS

27.1 PANEL BOARD (fig. 207)

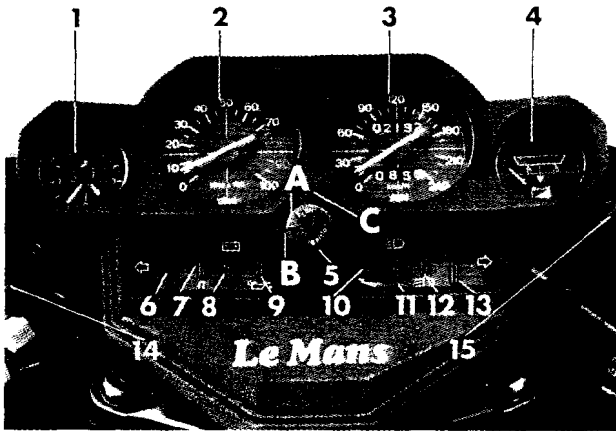

207

- 1 Clock.
- 2 Rev-counter.
- 3 Speedometer.
- 4 Voltmeter.
- 5 Ignition key:
 - «OFF» In line with mark «C» on the panel: machine at standstill. Key removable.
 - «A» In line with mark «C» on the panel (turned clockwise): machine ready to be started. All contacts «on». Key not removable.
 - «B» In line with mark «C» on the panel (turned clockwise). With switch «A» (fig. 5) in position «O» parking light is «on». Key removable.
- 6 Warning light (green), L/H turn signal.
- 7 Warning light (orange or green), gearbox in neutral position when lit.
- 8 Warning light (red) indicating insufficient current from generator. Should go out when the engine has reached a certain number of revs.
- 9 Warning light (red). Oil pressure indicator. Goes out when pressure is sufficient for normal engine lubrication. If not, the pressure is incorrect and the engine has to be stopped immediately and oil level topped up. The lubrication system should also be checked over.
- 10 Warning light (red) indicating low level of oil in the reservoir-master cylinder for the front left and rear brakes. When this light comes on, top up the reservoir ensuring there are no leakages in the hydraulic circuit.
- 11 Warning light (blue) indicating high beam on.
- 12 Warning light (green) indicating parking lights on.
- 13 Warning light (green) right turn signal.
- 14 Switch for emergency flashers.
- 15 Zero reset for speedometer.

27.2 LIGHT SWITCHES (fig. 208)

Are fitted on the L/H side handlebar.

Switch «A»:

- «E» parking light;
- «1» dual filament bulb lighting;
- «2» lights off.

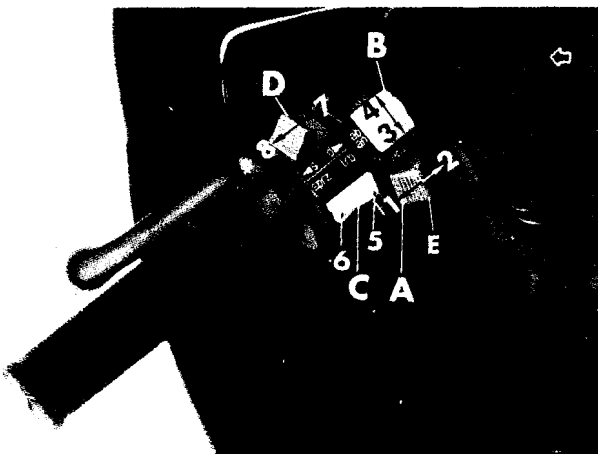

208

Switch «B»:

With switch «A» in position «1»:

- «3» low beam;
- «4» high beam.

27.3 HORN FLASHING LIGHT AND TURN SIGNAL CONTROLS (fig. 208)

Are fitted on the left handlebar.

Button «C»:

- «5» (horn) Horn control.
- «6» (flash) Flashing light control.

Switch «D»:

- «7» right turn light;
- «8» left turn light.

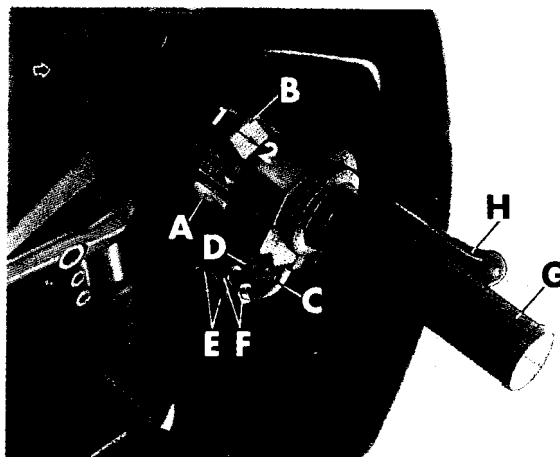

209

27.4 ENGINE STARTING AND STOPPING BUTTONS (fig. 209)

Are on the R/H side of the handlebar.

With mark «A» on the key in line with mark «C» on the panel (see fig. 207) the machine is ready to be started. To start the engine, proceed as follows:

- ensure switch «B» is in position «1»;
- pull the clutch lever completely;
- if the engine is cold, set the starter lever to position «A» (see fig. 217);
- press start button «A».

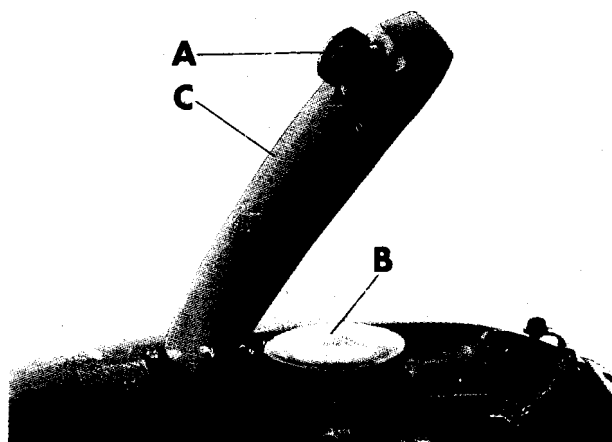

210

27.5 FUEL FILLER CAP (fig. 210)

To access to filler cap «B», turn key «A» and raise cover «C».

27.6 SADDLE LIFTING DEVICE (fig. 211)

Remove pin from the R/H side, remove grab strap «A» and press lever «B» forward.

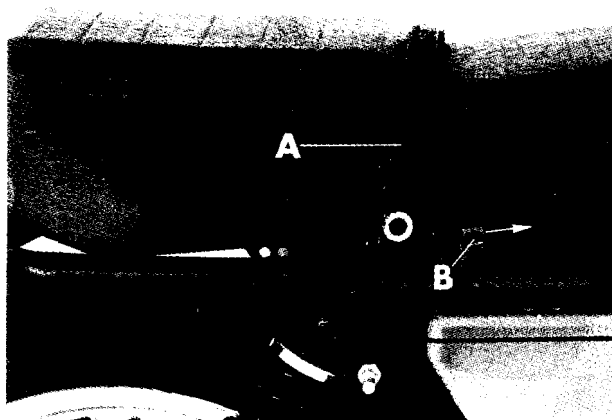

211

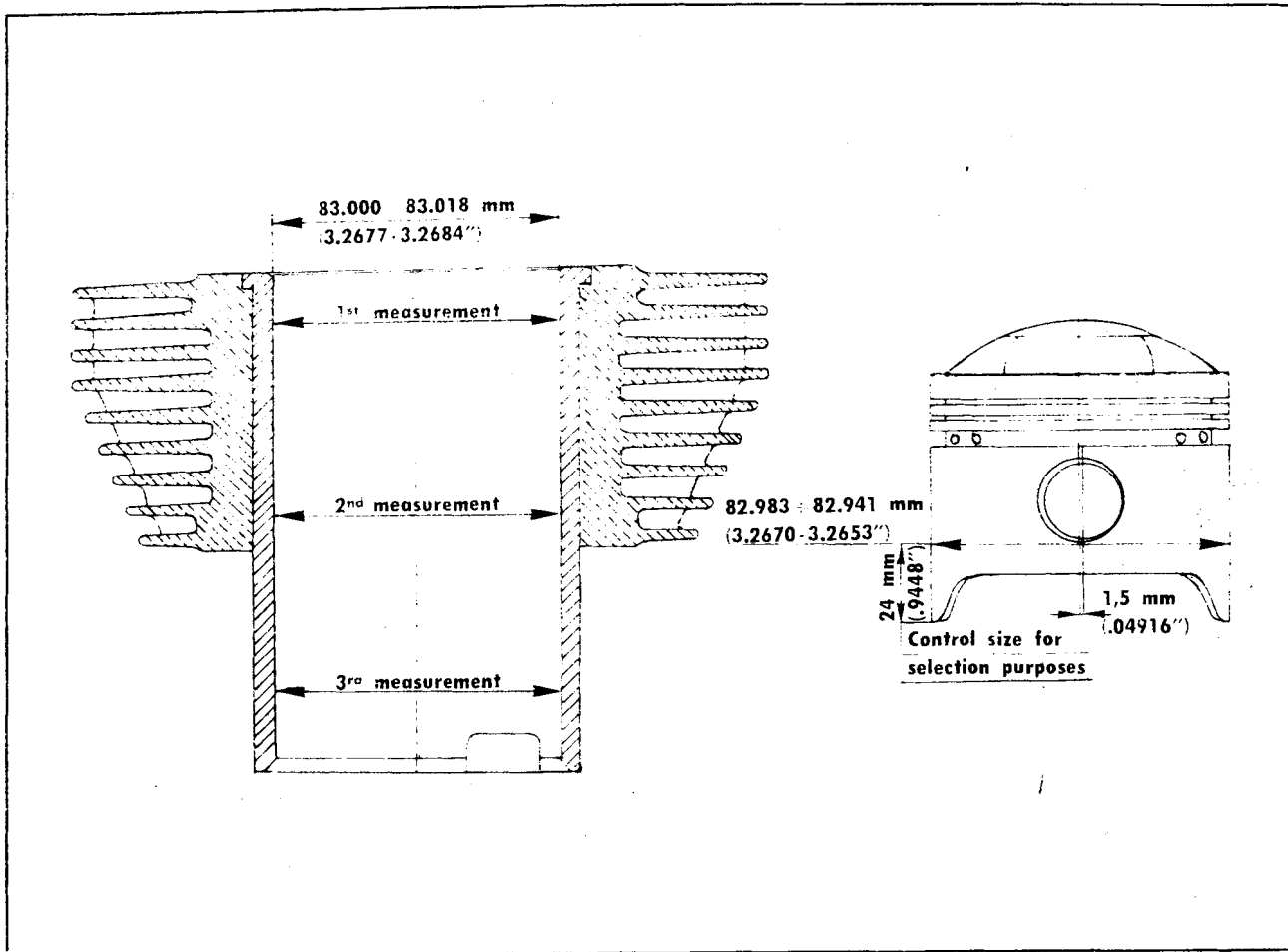

212

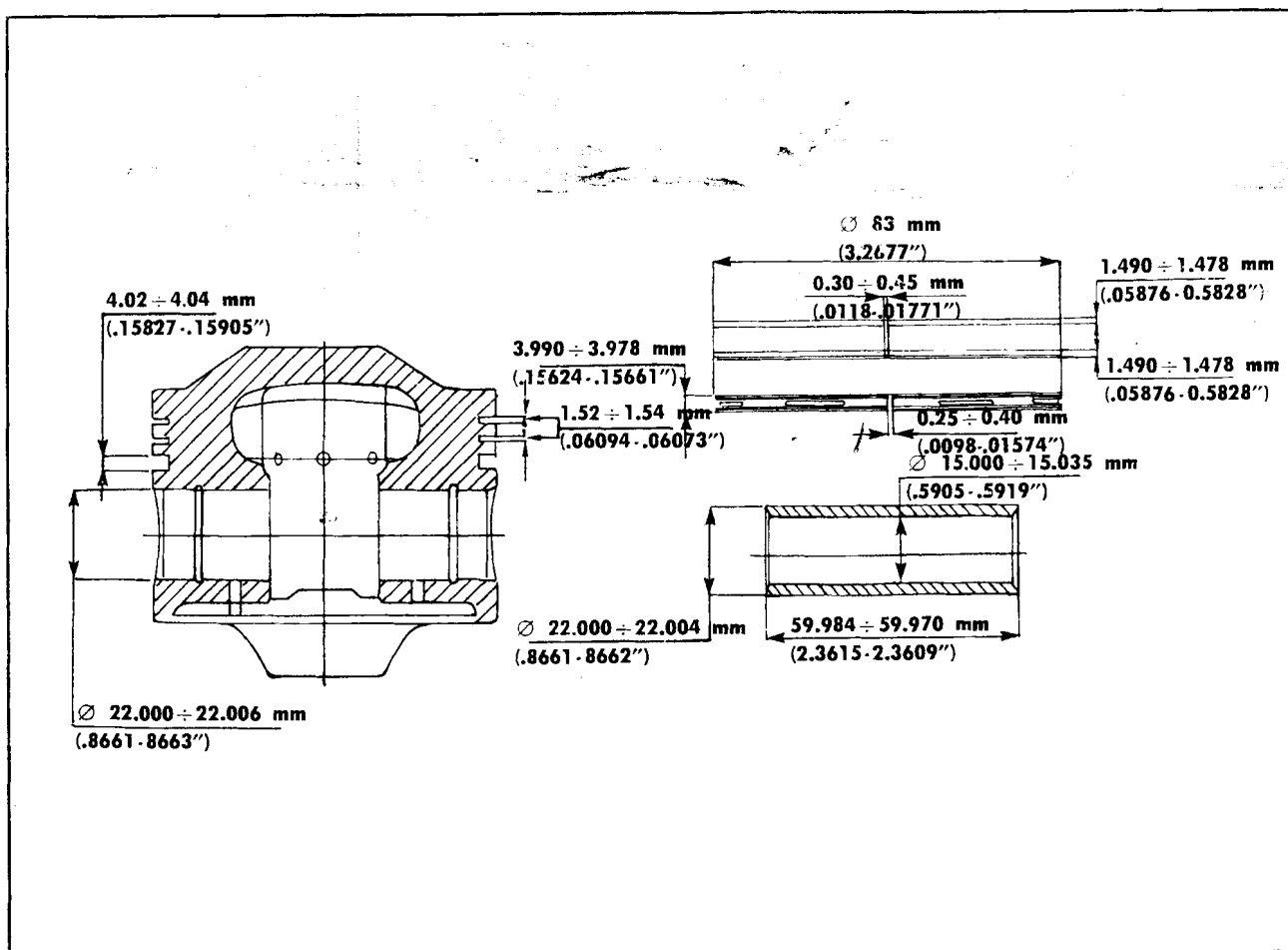

213

29.2 CRANKSHAFT (dwg n. 216)

Crankpin diameter:

ORIGINAL CRANKPIN SIZE mm	U/S BEARING		
	0.254 mm (.010")	0.508 mm (.020")	0.762 mm (.030")
44.008-44.020 (1.7325-1.7330")	43.754-43.766 (1.7225-1.7230")	43.500-43.512 (1.7125-1.7130")	43.246-43.258 (1.7026-1.7030")

SELECTION OF CRANKSHAFT

CLASS "A" (Blue mark at flywheel end) mm	CLASS "B" (White mark at flywheel end) mm
44.008-44.014 (1.7325-1.7327")	44.014-44.020 (1.7327-1.7330")

Crankpin - bearing clearance:

- minimum 0.030 mm (.0011");
- maximum 0.054 mm (.0021").

CHECKING WEIGHT FOR ENGINE BALANCING

The con-rod complete with nuts and bolts should be of same weight. Max permissible difference: 3 grams.

The crankshaft is statically balanced by adding a weight of 1.586 ÷ 1.616 kg (3.49-3.57 lbs).

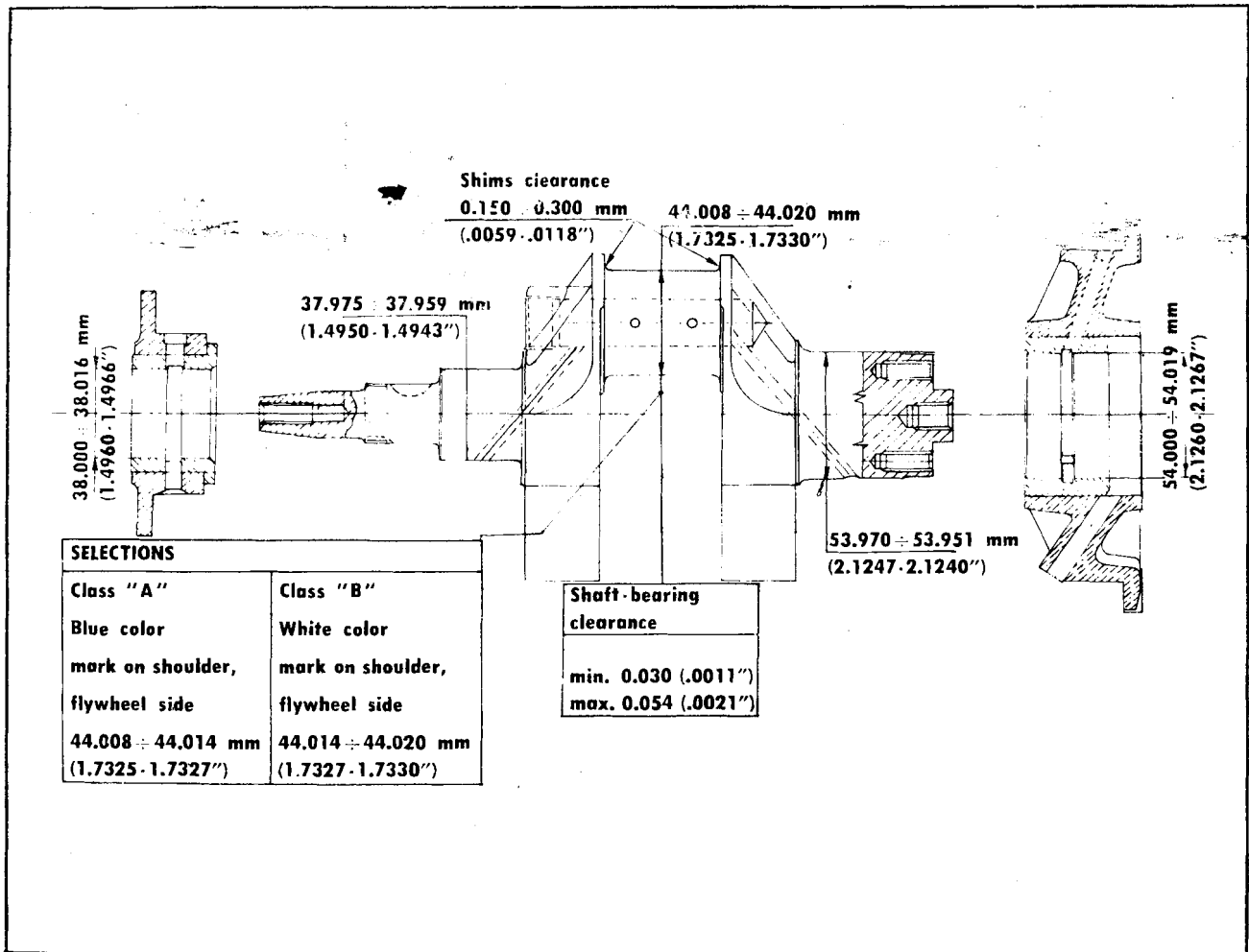

30.1 CARBURETTORS (fig. 217)

2 Dell'Orto carburetors «PHF 36 B(D)» (right), «PHF 36 B(S)» (left).

Controls

- Throttle control grip on the right handlebar.
- Starter lever for cold engine starts on the left hand cylinder rocker cover.

- «A» Start position.
- «B» Riding position.

Carburettor settings

Choke	36 mm Ø
Throttle valve	60
Atomizer	265 A B
Main jet	140
Idling jet	60
Starter jet	70
Pump jet	38
Taper needle	K 5 (2nd notch)
Float	10 grams
Idling screw:	1 1/2 turn open.

30.2 FLOATS LEVELLING

See para «15.2» in chapter «Carburation». The only difference is the checking template part N. 14 92 69 50. Being these 10 grams floats the size from the carburettor body to the float top should be 23.5 mm (.96") see fig. 84.

30.3 ADJUSTING IDLING SPEED WITHOUT VACUUMETER (fig. 217)

Proceed as follows:

- 1 Ensure that with starter lever in position «B» there is about 3 mm play (.118") between the starter cable ends and adjusting screws «E» for both carburetors.
- 2 Ensure that with the throttle grip fully closed there is a play of about 1-1.5 mm (.039-.059"). If not, loosen nuts «F» and screw in or out cable tensioners «E». At the end of this operation tighten nuts «F» (fig. 209).
- 3 Run the engine up to its normal operating temperature. Screw idling screws «C» fully in and then screw them out one and a half turn.
- 4 Using both hands at the same time, check if the exhaust pipe pressures are equal. If there is any noticeable pressure difference, operate on screw «D» of one carburettor until the pressure will be the same as the other (idling speed will have to be kept at about 1000-1100 rpm and accordingly it may be necessary to screw in the screw of the carburettor for the cylinder giving a lower exhaust pressure, or screw out the screw of the carburettor for the cylinder giving a higher exhaust pressure.

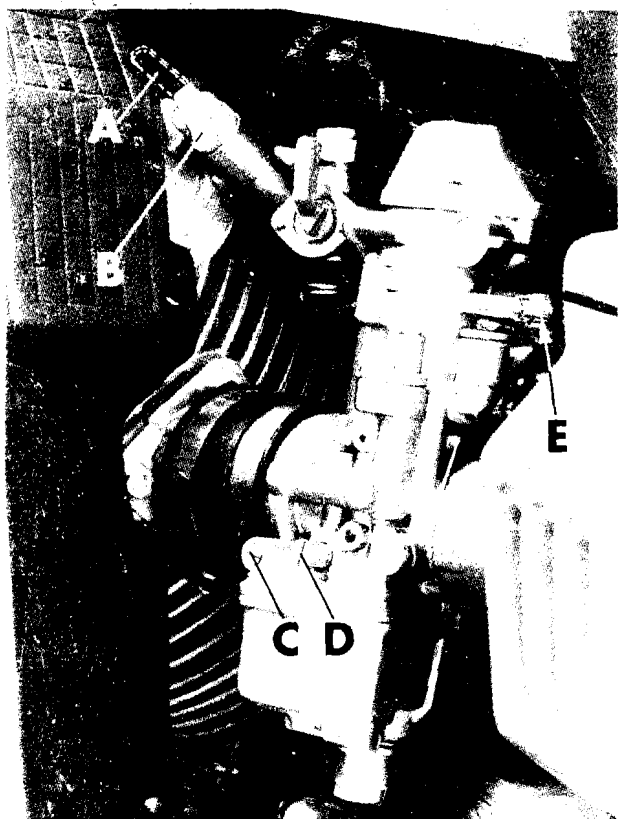

5 Acting on screws «C» obtain the best carburation for each cylinder (this will be noticed by a slight increase of rpm) and adjust the tick-over speed according to point 4.

6 Disconnect one spark plug lead at a time and check that the engine in both cases stops after firing the same number of strokes. If this does not occur, screw out screw «D» of the carburettor for the cylinder that makes the engine fire more strokes or screw in the screw of the carburettor making the engine fire less strokes.

7 Adjust idling speed at 1000-1100 rpm by screwing in or out both screws «D» by the same amount.

8 Ensure that the slides open simultaneously by proceeding as follows: by the assistance of a second person, gradually turn the throttle control grip and check that the exhaust pipe pressure increases in synchronization, using both your hands. If the pressure increase of one cylinder is advanced, act on its carburettor by gradually screwing in adjuster «E» after loosening conternut «F» (fig. 209) until the synchronization of both exhaust pipe pressures is reached.

30.4 CHECKING THE CARBURATION WITH A VACUOMETER

Proceed as follows:

1 Make sure that with starter lever in the «B» position there is a clearance of about 3 mm (.118") between the starter cable ends and the wire adjusting screws «E» of both carburettors (fig. 217).

2 Ensure that with the twist grip fully closed between the cable ends and cable adjusters «E» (at the handlebar end) there is a clearance of 1-1.5 mm (.039-.059") for both carburettors. If not, loosen conternuts «F» and screw in or out adjusting screws «E» not forgetting to re-tighten nuts «F» after adjustment (see fig. 209).

3 Adjust screw «C» (fig. 217) screwing it in fully and then unscrewing it 1 1/2 turns for both carburettors. (Undoing this screw increases the petrol flow and viceversa decreases it).

4 Remove inlet pipe «A» sealing plugs and in the holes fit up hoses «B» of vacuumeter «C» (see fig. 85).

5 To adjust the tick-over speed (to be done on a warm engine) operate as follows:

- start the engine with the throttle grip at minimum opening (1000-1100 rpm) operating on slide adjuster «D» in fig. 217. At this stage, check that both mercury columns «D» of vacuumeter «C» (fig. 85) are at same height and, if not act on screw «D» (fig. 217) to obtain this condition.

6 Re-adjust the positions of pilot screws «C» (fig. 217) to the point giving the lowest possible number of revolutions. Then re-check the position of both mercury columns «D» on vacuumeter dial «C» (fig. 85) and eventually repeat the operation at 5.

7 Synchronize the carburettors as follows (after adjusting idling speed):

- start the engine and gradually accelerate, checking that both mercury columns on vacuo-

meter dial «C» are equally lined up (fig. 85). If not, operate on cable adjusters «E» after having loosened conternuts «F» (see fig. 209) of the throttle control cables (handlebar end) until the said line up is obtained;

- after this check, undo the hoses from the inlet ports «B» (fig. 85) and retighten all retaining screws and washers.

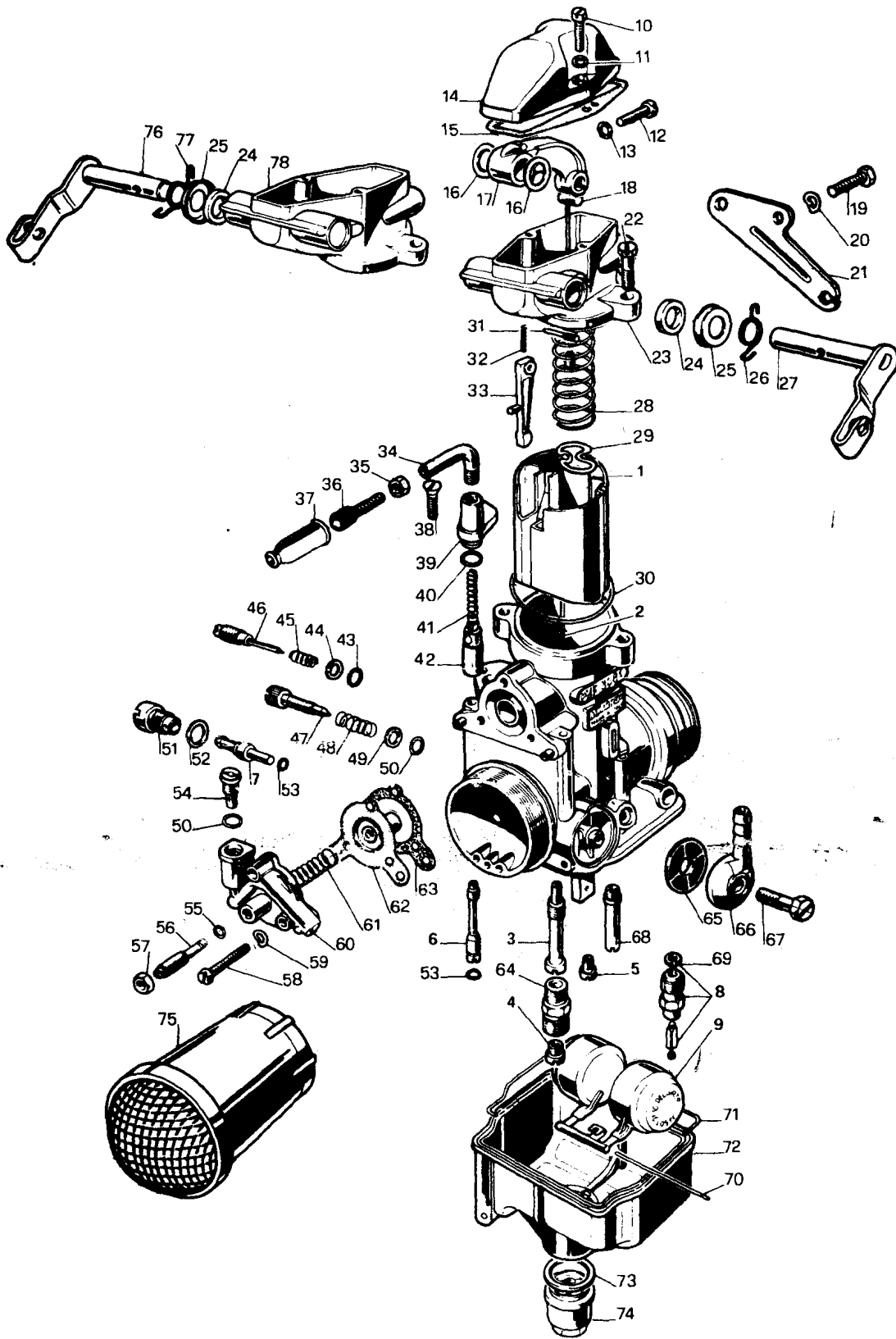

30.5 CARBURETTOR COMPONENTS

- 1 Throttle valve (slide).
- 2 Needle K.
- 3 Main nozzle AB.
- 4 Main jet.
- 5 Pilot jet.
- 6 Starter jet.
- 7 Accelerator pump jet.
- 8 Float needle valve.
- 9 Float unit.
- 10 Top cover screw.
- 11 Gasket.
- 12 Throttle control lever screw.
- 13 Washer.
- 14 Top cover.
- 15 Cover gasket.
- 16 Washer.
- 17 Throttle slide crank.
- 18 Intermediate slide control cable.
- 19 Support screw.
- 20 Washer.
- 21 Support.
- 22 Mixture chamber cover screw.
- 23 Chamber cover.
- 24 Lever washer.
- 25 Lever cap cover.
- 26 Lever return spring.
- 27 Throttle gas lever.
- 28 Return spring.
- 29 Needle clip.
- 30 Gasket, mixture chamber cover.
- 31 Pin, accelerator pump lever.
- 32 Spring.
- 33 Throttle pump arm.
- 34 Tube.
- 35 Cable adjuster securing screw.
- 36 Cable adjuster.
- 37 Starter cable cap.
- 38 Starter cover screw.
- 39 Starter cover.
- 40 Cover gasket.
- 41 Starter valve return spring.
- 42 Starter valve.
- 43 Idle adjuster washer.
- 44 Washer, flat.
- 45 Idle adjusting screw spring.
- 46 Idle screw.
- 47 Throttle valve (slide) adjusting screw.
- 48 Throttle valve spring.
- 49 Flat washer.
- 50 Washer.
- 51 Accelerator pump jet holder.
- 52 Jetholder washer.
- 53 Washer.
- 54 Accelerator pump valve.
- 55 Pump diaphragm screw washer.
- 56 Pump diaphragm screw.
- 57 Diaphragm securing nut.
- 58 Accelerator pump cover screw.
- 59 Washer.
- 60 Pump cover.
- 61 Pump diaphragm spring.
- 62 Pump diaphragm.
- 63 Pump diaphragm gasket.
- 64 Main jetholder.
- 65 Filter screen.
- 66 Petrol feed union.
- 67 Union screw.
- 68 Accelerator pump feeder.
- 69 Needle gasket.
- 70 Float pivot pin.
- 71 Sealing gasket.
- 72 Float bowl.
- 73 Float bowl plug gasket.
- 74 Float bowl plug.
- 75 Air intake tube.
- 76 Pin, throttle control.
- 77 Pin return spring.
- 78 Cover, mixture chamber.

31 REAR SUSPENSION

(see chapter 20)

Features of suspension spring «A» and «B»

Spring «B» (see description and fig. 138/1).

32 FRONT SUSPENSION AND STEERING

(see chapter 21)

Inspections

Short spring (see description and fig. 145).

Long spring «Modifications for model SP» (description and fig. 146).

33 WHEELS

(see chapter 23)

Front wheel (see para 23.2).

Rear wheel (see para 23.4).

Removal and fitting the tires on the rim (see para 23.9).

Air bleeding from braking circuits (see «2» in para 23.10).

Checking and replacing fluid level in reservoirs (see «3» para 23.10).

34 ELECTRICAL EQUIPMENT

(see chapter 24)

34.1 BATTERY (see para 24.1)

The battery is a 12 V type with a 20 Ah capacity (on request a 12 V - 32 Ah battery can be made available).

34.2 SPARK PLUG RECOMMENDATIONS

- Bosch W 230 T 30
- Champion N 9 Y
- Lodge 2 HLN Y

34.3 IGNITION TIMING «FIXED ADVANCE»

(see para 24.12)

34.4 CHECKING IGNITION ADVANCE (FIXED + AUTOMATIC) USING A STROBE LIGHT

(see para 24.13)

N.B. *When carrying out the operations described in para 24.12 and 24.13 follow strictly the data in «Ignition advance data» and drawing fig. 218/1.*

34.5 IGNITION DATA (see dwg fig. 218/1)

Initial advance (fixed)	8°
Automatic advance	26°
Total advance (fixed + automatic)	34°
Contact points gap: 0.37 ÷ 0.43 mm (.014-.017")	
Spark plug points gap: 0.5 mm (.019")	

35 HORN AND LIGHTING EQUIPMENT

35.1 REPLACING THE LAMPS

Headlight (fig. 219)

To replace the bulb, disconnect the faston cables, remove rubber cap «G», and withdraw bulb «D» by turning springs «E».

After changing, make sure no other cables have been inadvertently disconnected, especially the parking light cable.

Parking light holder «F» is a pressure fit.

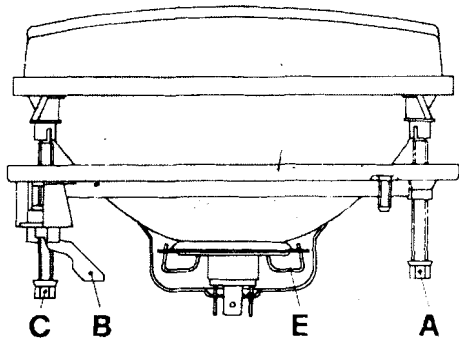
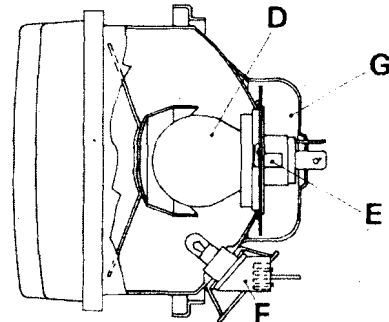
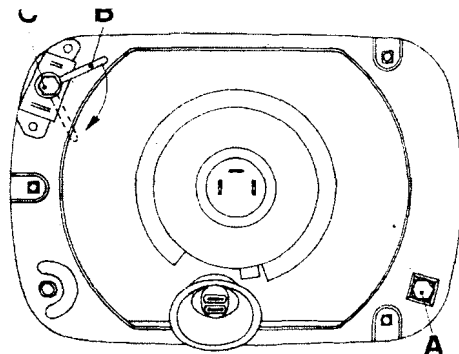

Tail light (fig. 221)

Undo screws «A» securing the reflector to tail light, push the bulb inwards turning to the left to slip it out.

Front and rear turn signal bulbs (fig. 220 and 221)

Undo screws «A» (fig. 220) and «B» (fig. 221) securing the reflectors to the lamp, push the bulb inwards turning it to the left to free it.

In refitting the reflectors do not overtighten to prevent breakages.

Panel, tachometer, rev-counter, voltmeter, and clock lights.

Remove the bulbholders and replace the bulbs.

219

35.2 LAMPS (12 V)

Headlight

- High and low beam 40/45 W
- Town driving or parking light 4 W

Tail light

- Number plate and stop 5/21 W

Turn signals 21 W

Speedo and rev-counter lights 3 W

Panel indicators 2 W

Voltmeter and clock 3 W

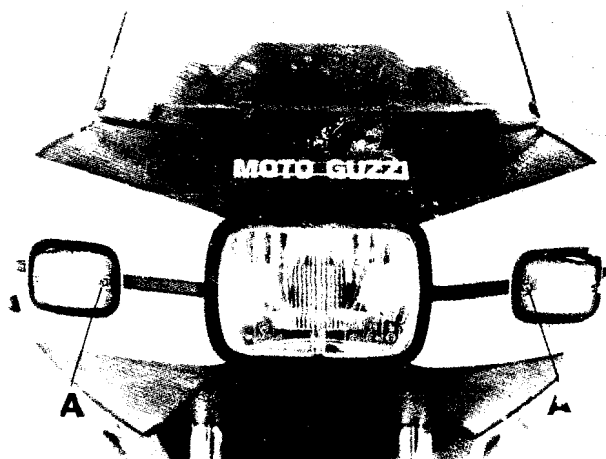

220

35.3 HEADLIGHT BEAM ADJUSTMENT

(fig. 219)

For safe riding and not to trouble crossing riders, the headlight has always to be kept at same height.

Horizontal setting is adjusted by screw «A».

Vertical setting is adjusted by screw «C» to the point where correct height is reached.

The center of the high beam has not to be higher than 0.833 meters (32-33") measured at 3 meters (10 ft) with the motorcycle off the stand and the rider in the saddle.

Operating on lever «B» it is possible to quickly change the vertical setting to suit load conditions (1 or 2 persons in the saddle).

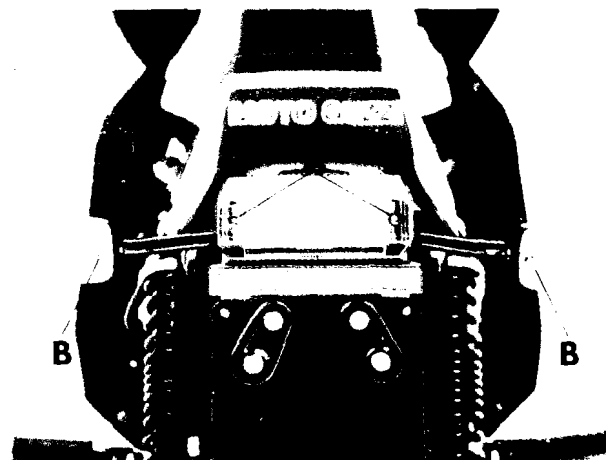

221

36.1 WITH UNPRINTED PANEL CIRCUIT
(fig. 222)

- 1 Tachometer speedometer (3 W bulb)
- 2 Rev-counter (3 W bulb)
- 3 High beam warning light (1.2 W bulb)
- 4 Oil pressure warning light (1.2 W bulb)
- 5 Neutral warning light (1.2 W bulb)
- 6 Parking light, warning light (1.2 W bulb)
- 7 Generator charge, warning light (1.2 W bulb)
- 8 Low beam (40 W) } (40/45 W bulb)
- 9 High beam (45 W) }
- 10 Front turn indicator, right (21 W bulb)
- 11 Front turn indicator, left (21 W bulb)
- 12 Engine starting and stopping button
- 13 Flashing light, turning lights, horn switch
- 15 Horn (consumption 3.5 A)
- 16 Front brake cutout switch
- 17 Flashing light relay
- 18 Rear brake switch
- 19 Battery
- 20 Regulator
- 21 Rectifier
- 22 Alternator
- 23 Starter motor relay
- 24 Starter motor
- 25 Turn signal, rear, left (21 W bulb)
- 26 Stop light (21 W + 21 W)
- 27 Number plate and parking light (5 + 5 W bulb)
- 28 Turn indicator, right, rear (21 W bulb)
- 29 Flasher unit, turn signals
- 30 Oil pressure switch
- 31 Neutral indicator switch
- 32 Terminal block with fuses (16 A)
- 33 Contact breaker
- 34 Coils
- 35 Ignition switch (3 positions)
- 36 Spark plugs
- 37 Parking lights, front (4 W bulb)
- 38 Warning light, brake fluid level (1.2 W)
- 39 Brake fluid level indicator
- 40 Flashing light bracket
- 41 Voltmeter (3 W bulb)
- 42 Clock (3 W bulb)
- 43 Warning light, left turn indicator (1.2 W bulb)
- 44 Warning light, right turn indicator (1.2 W bulb)
- 45 4-way connector
- 46 3-way connector
- 47 Switch for simultaneous turning on of all flashers

IGNITION KEY POSITION

- «1» = No contact
- «2» = All contacts «ON»
- «3» = Contact on terminals 18/30 only

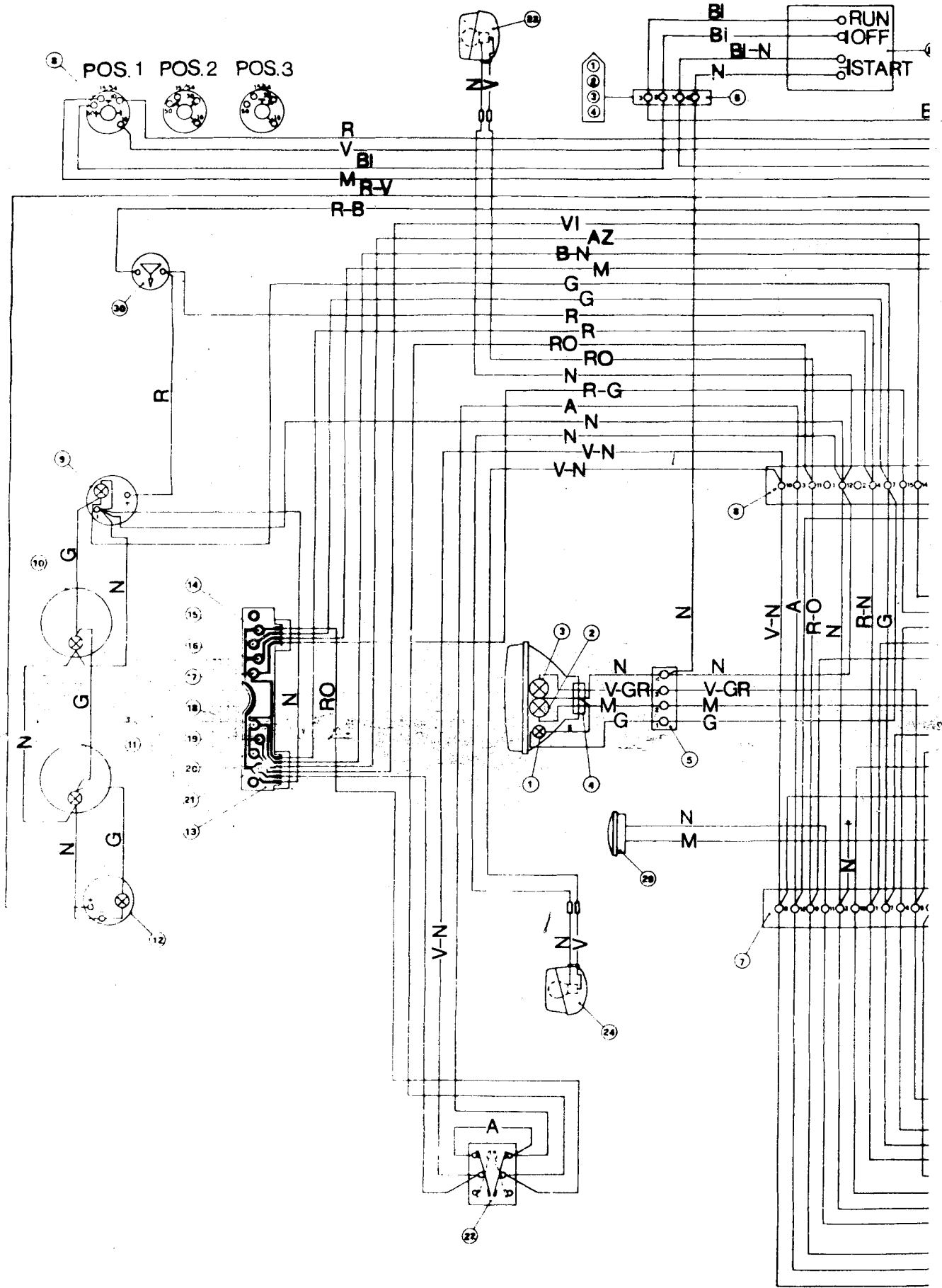

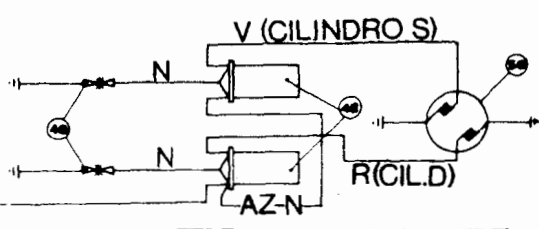

- N = nero (black)
- G = giallo (yellow)
- V = verde (green)
- R = rosso (red)
- B = blu (blue)
- VI = viola (violet)
- RO = rosa (pink)
- A = arancione (orange)
- M = marrone (brown)
- BI = bianco (white)
- GR = grigio (grey)
- AZ = azzurro (azure)
- BN = blu-nero (blue-black)
- VN = verde-nero (green-black)
- RN = rosso-nero (red-black)
- BIN = bianco-nero (white-black)
- AZN = azzurro-nero (azure-black)
- RV = rosso-verde (red-green)
- RB = rosso-blu (red-blue)
- RG = rosso-giallo (red-yellow)
- VGR = verde-grigio (green-grey)

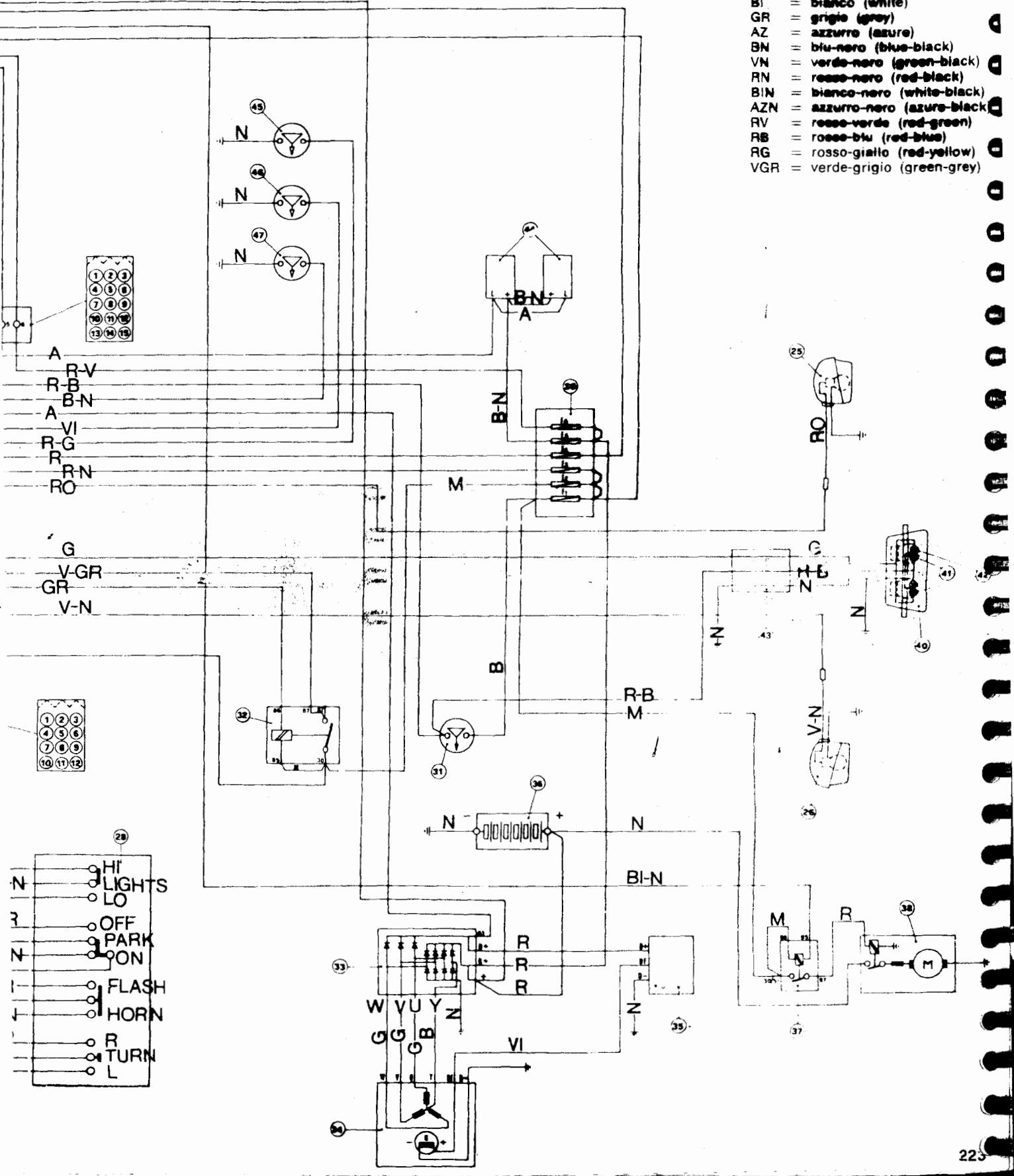

36.2 WITH PRINTED PANEL CIRCUIT

(fig. 223)

- 1 Front parking light (4 W)
- 2 High beam (45 W)
- 3 Low beam (40 W) } (40/45 W bulb)
- 4 3-way connector «AMP», headlight
- 5 4-way connector «Molex»
- 6 15-way connector
- 7 12-way connector
- 8 Light switch, 3 positions
- 9 Voltmeter (3 W bulb)
- 10 Speedometer (3 W bulb)
- 11 Rev-counter (3 W bulb)
- 12 Clock (3 W bulb)
- 13 Warning lights carrier with printed circuit
- 14 Warning light, right turn light (1.2 W bulb)
- 15 Warning light, parking light (1.2 W bulb)
- 16 Warning light, high beam (1.2 W bulb)
- 17 Warning light, oil fluid level (1.2 W bulb)
- 18 Warning light, oil pressure (1.2 W bulb)
- 19 Warning light, generator charge (1.2 W bulb)
- 20 Warning light, neutral position
- 21 Warning light, left turn signal (1.2 W bulb)
- 22 Switch for simultaneous switch on of all flashers
- 23 Front right turn light (21 W bulb)
- 24 Front left turn light (21 W bulb)
- 25 Rear right turn light (21 W bulb)
- 26 Rear left turn light (21 W bulb)
- 27 Engine starting and stopping button
- 28 Horn, flashers and turn lights switch
- 29 Horn
- 30 Front brake switch (STOP)
- 31 Rear brake switch (STOP)
- 32 Flashing lights relay (FLASH)
- 33 Rectifier
- 34 Alternator (14 V - 20 A)
- 35 Regulator
- 36 Battery
- 37 Starter relay
- 38 Starter motor
- 39 Terminal board with fuses (16 A)
- 40 Tail light
- 41 Rear stop light (21 W bulb)
- 42 Number plate and rear parking light (5 W bulb)
- 43 3-way connector
- 44 Flasher unit
- 45 Brake fluid level indicator
- 46 Neutral position indicator
- 47 Oil pressure indicator
- 48 Coils
- 49 Spark plugs
- 50 Contact breaker

37 CONVERSION KITS AVAILABLE ON REQUEST

The «850 Le Mans II» can be converted into a racing motorcycle by fitting a new gearbox set of straight toothed gears and new mainshafts to give different gearbox ratios.

Important:

When this kit is fitted, the «850 Le Mans II» is automatically excluded from all guarantee rights.

Likewise, by fitting the boost up kit, the motorcycle will no longer comply with the **Highway code regulations** nor with the **type approval specifications** and accordingly cannot be circulated on open roads but only on closed tracks.

37.1 THIS KIT (PART N. 14 21 00 41) CAN BE SUPPLIED ON REQUEST AND CONSISTS OF (fig. 224).

FIG. N.	REFERENCE	DESCRIPTION	QTY.
1	14 21 05 40	Main shaft (Z = 24 - 22 - 20 - 17)	1
1	14 21 05 41	Main shaft (Z = 24 - 22 - 19C - 16C)	1
2	14 21 20 40	5th speed gear on mainshaft (Z = 25)	1
3	14 21 11 40	Transmission gear (Z = 16)	1
3	14 21 11 41	Transmission gear (Z = 17)	1
4	14 21 52 40	5th speed gear on layshaft (Z = 19)	1
5	14 21 51 40	4th speed gear on layshaft (Z = 20)	1
6	14 21 48 40	3rd speed gear on layshaft (Z = 22)	1
7	14 21 45 40	2nd speed gear on layshaft (Z = 24)	1
7	14 21 45 41	2nd speed gear on layshaft (Z = 24C)	1
8	14 21 42 40	1st speed gear on layshaft (Z = 26)	1
8	14 21 42 41	1st speed gear on layshaft (Z = 26C)	1

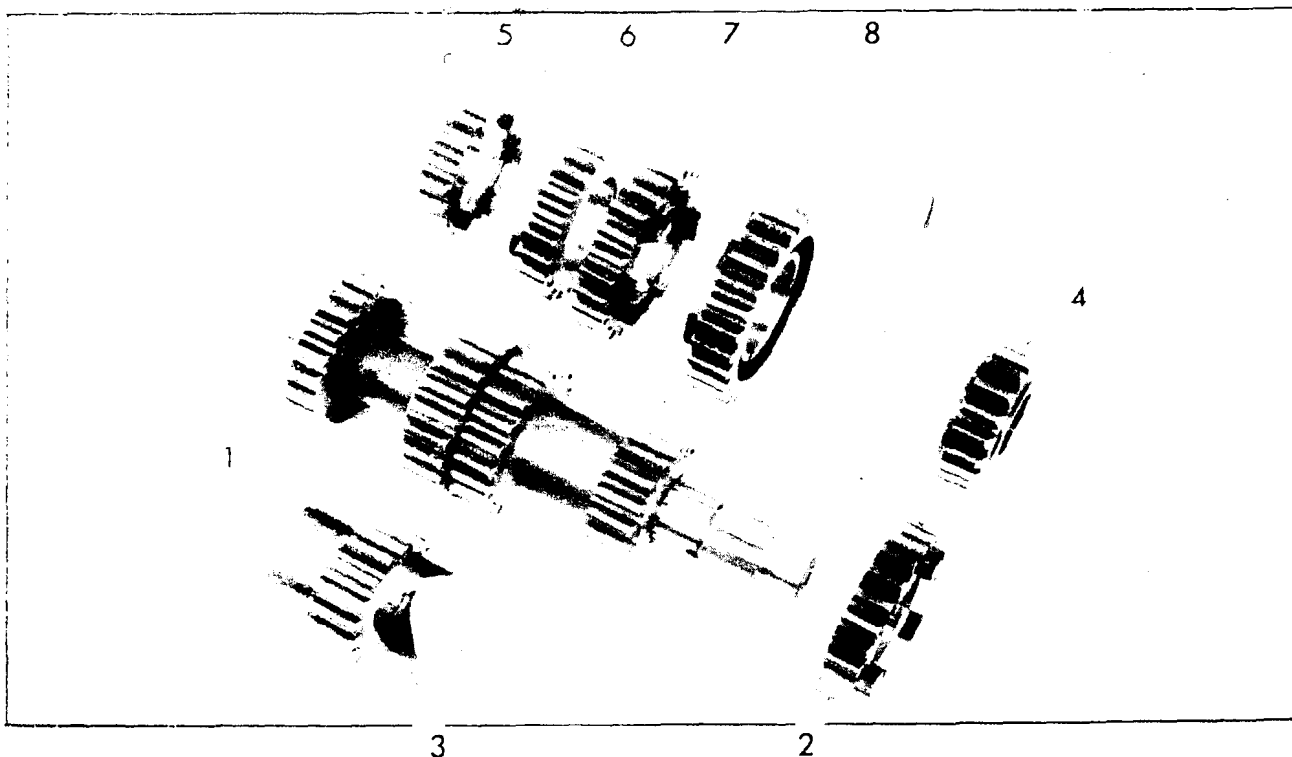

Note:

1 Gears marked «C» next to the teeth number have to be fitted in a mated condition.

These parts are identified by:

- a round mark of turning at the center of the tothing for single 1st and 2nd speed gears on layshaft;
- two round turning marks on the central mating part of the double 1st and 2nd speed gears on main shaft.

The following bevel gear sets can also be made available:

1 6/32 - ratio 5,333 - part n. 17 35 46 90 - to be mounted with double cardan joint 14 32 80 40 and sleeve 18 32 77 00.

2 7/33 - ratio 4,714 - part n. 17 35 46 50 - to be mounted with double cardan joint 17 32 60 50 and sleeve 12 32 77 00.

3 8/33 - ratio 4,125 - part n. 14 35 46 40 - to be mounted with double cardan joint 14 32 80 40 and sleeve 18 32 77 00.

4 9/34 - ratio 3,778 - part n. 18 35 46 50 - to be mounted with double cardan joint 14 32 80 40 and sleeve 18 32 77 00.

GEARBOX TYPE «A» (see fig. 225)

with modified transmission gear of clutch shaft: Z/17 or Z/16

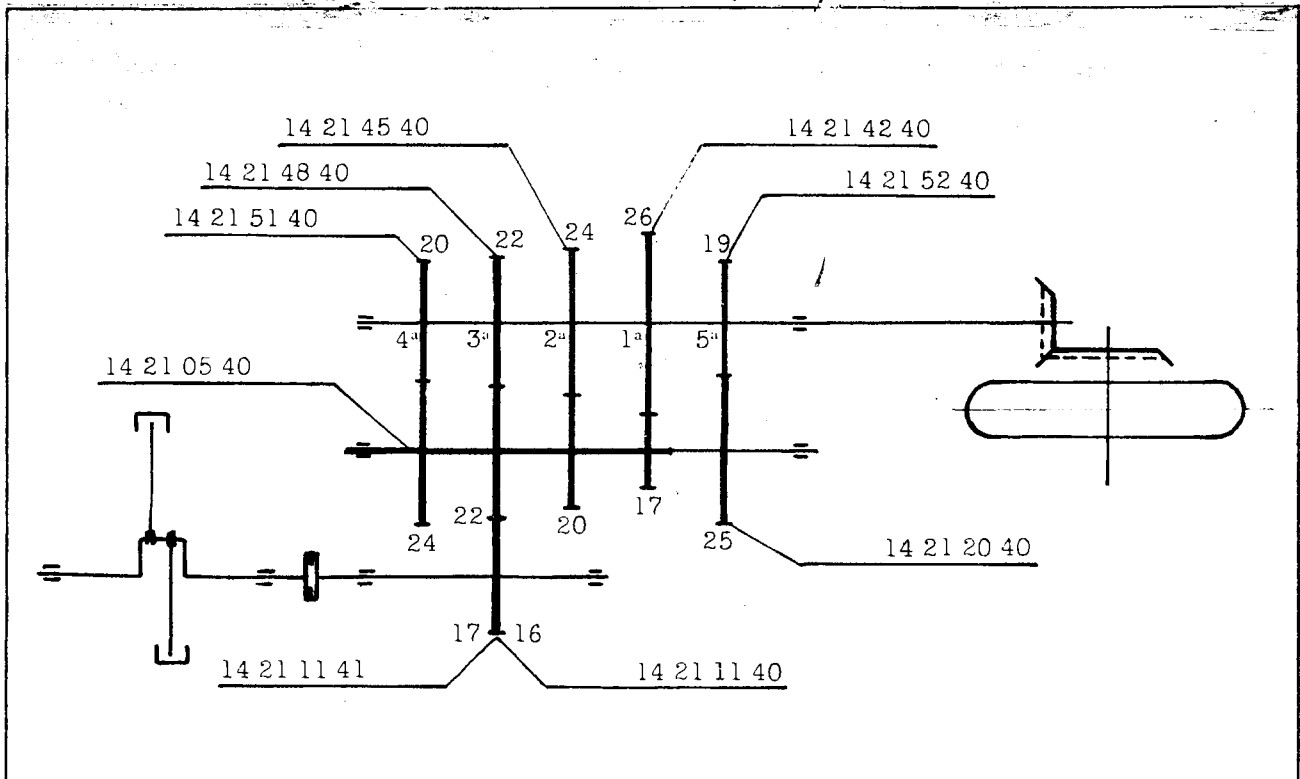

225

OVERALL GEAR RATIOS

with transmission gear of clutch shaft Z/17 part n. 14 21 11 41

BEVEL GEAR SET	1st	2nd	3rd	4th	5th
6/32 = 5,333	10,554	8,282	6,901	5,749	5,242
7/33 = 4,714	9,329	7,321	6,10	5,03	4,634
8/33 = 4,125	8,163	6,406	5,338	4,447	4,055
9/34 = 3,778	7,477	5,867	4,889	4,073	3,714
THEORETICAL SPEEDS AT 7.500 R.P.M. (rear tyre development mm 2.020)					
BEVEL GEAR SET	1st	2nd	3rd	4th	5th
6/32	85,27	108,66	130,41	156,54	171,69
7/33	96,47	122,93	147,54	177,16	194,21
8/33	110,25	140,49	168,60	202,38	221,94
9/34	120,36	153,40	184,08	220,96	242,32

OVERALL GEAR RATIOS

with transmission gear of clutch shaft Z/16 part n. 14 21 11 40

BEVEL GEAR SET	1st	2nd	3rd	4th	5th
6/32 = 5,333	11,210	8,799	7,333	6,106	5,573
7/33 = 4,714	9,909	7,778	6,482	5,398	4,926
8/33 = 4,125	8,671	6,806	5,672	4,725	4,311
9/34 = 3,778	7,941	6,234	5,195	4,326	3,948
THEORETICAL SPEEDS AT 7.500 R.P.M. (rear tyre development mm 2.020)					
BEVEL GEAR SET	1st	2nd	3rd	4th	5th
6/32	80,28	102,28	122,73	147,39	161,49
7/33	90,82	115,71	138,84	166,72	182,70
8/33	103,79	132,23	158,67	190,47	208,76
9/34	113,33	144,36	173,24	208,04	227,96

GEARBOX TYPE «B» - 1st and 2nd low (see fig. 226)

with modified transmission gear of clutch shaft: Z/17 or Z/16

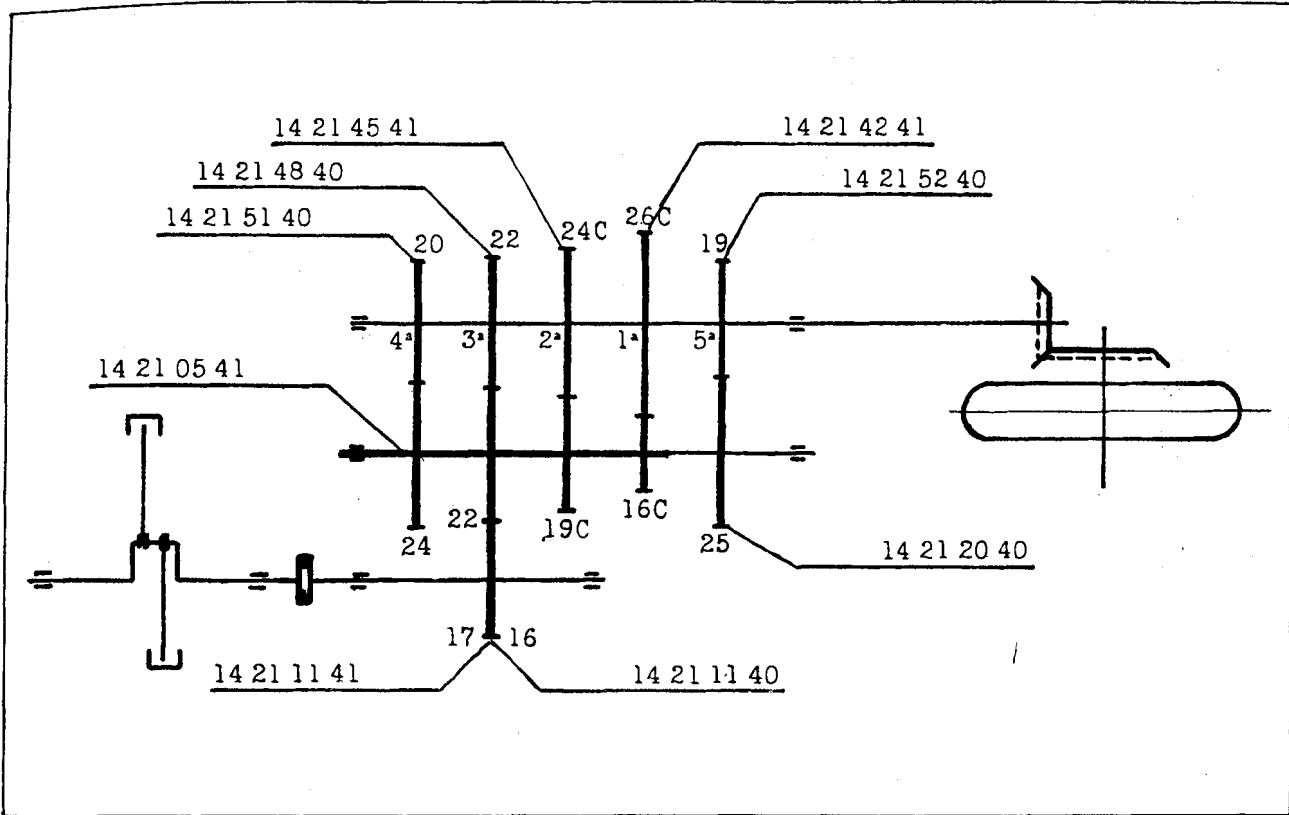

226

OVERALL GEAR RATIOS

with transmission gear of clutch shaft Z/17 part n. 14 21 11 41

BEVEL GEAR SET	1st	2nd	3rd	4th	5th
6/32 = 5,333	11,215	8,714	6,901	5,749	5,242
7/33 = 4,714	9,914	7,703	6,10	5,08	4,634
8/33 = 4,125	8,675	6,740	5,338	4,447	4,055
9/34 = 3,778	7,945	6,177	4,889	4,073	3,714

THEORETICAL SPEEDS AT 7.500 R.P.M. (rear tyre development mm 2.020)

BEVEL GEAR SET	1st	2nd	3rd	4th	5th
6/32	80,24	103,28	130,41	156,54	171,69
7/33	90,78	116,83	147,54	177,16	194,21
8/33	103,74	133,53	168,60	202,38	221,94
9/34	113,27	145,70	184,08	220,96	242,32

OVERALL GEAR RATIOS

with transmission gear of clutch shaft Z/16 part n. 14 21 11 40

BEVEL GEAR SET	1st	2nd	3rd	4th	5th
6/32 = 5,333	11,914	9,263	7,333	6,106	5,573
7/33 = 4,714	10,531	8,188	6,482	5,398	4,926
8/33 = 4,125	9,215	7,165	5,672	4,725	4,311
9/34 = 3,778	8,440	6.562	5,195	4,326	3,948
THEORETICAL SPEEDS AT 7.500 R.P.M. (rear tyre development mm 2.020)					
BEVEL GEAR SET	1st	2nd	3rd	4th	5th
6/32	75,54	97,16	122,73	147,39	161,49
7/33	85,46	109,91	138,84	166,72	182,70
8/33	97,66	125,61	158,67	190,47	208,76
9/34	106,63	137,15	173,24	208,04	227,96

37.2 ENGINE BOOSTUP KIT PART N. 14 99 97 40 - «850 LE MANS II»

This includes:

PART N.	Q.TY	DESCRIPTION
14 00 32 40	1	Flange, crankcase - Oil sump
14 00 36 00	1	Gasket, flange
14 15 33 40	1	Cam shaft
14 02 08 40	2	Gasket
14 11 26 40	1	Right carburettor
14 11 26 41	1	Left carburettor
14 11 50 40	1	Right manifold
14 11 50 41	1	Left manifold
14 12 07 41	1	Exhaust pipes
14 12 30 41	1	Right silencer
14 12 29 41	1	Left silencer
14 12 39 41	1	Silencer connecting tube
98 05 23 90	4	Screw, flange securing
98 62 03 55	14	Screw, flange securing

This conversion is completed by flaring and polishing the intake and outlet ducts, also by shimming the valve springs as shown in drawing n. 227.

INLET

Fit 1 to 7 washers part n. 14 03 73 00 between part n. 13 03 72 00 and the cylinder head.

OUTLET

Fit 0 to 6 washers part n. 14 03 73 00 between part n. 13 03 72 00 and the cylinder head.

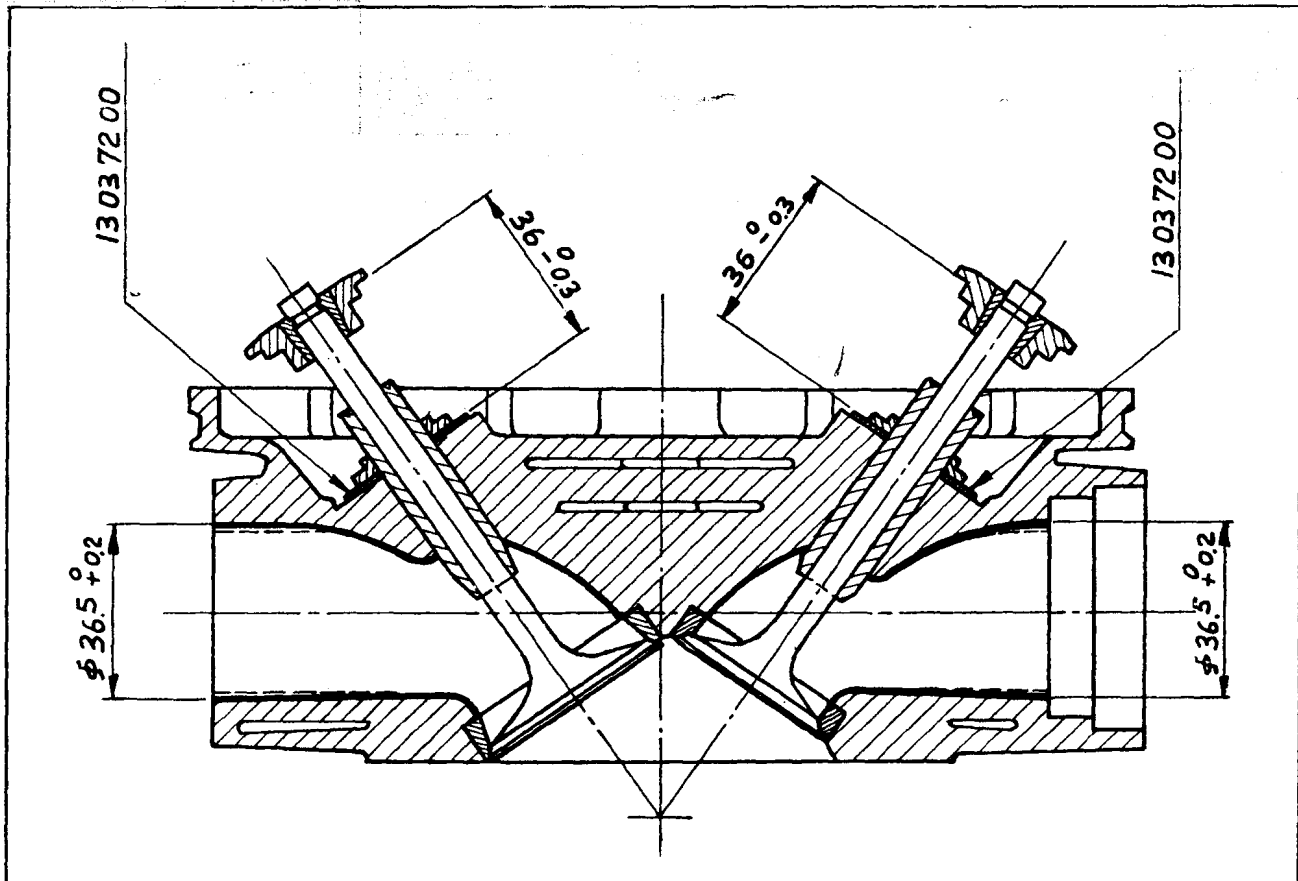

227



850-T3

ADDITIONS AND CHANGES FOR 850-T 3 MODEL

MAIN FEATURES

ENGINE

2-cylinder 4-stroke
Cylinder disposition « V » 90°
Bore mm 83
Stroke mm 78
Displacement cc 844
Compression ratio 9,5
Output HP 68,5 SAE at 7.000 r.p.m.

Valve gear

O.H.V. push rod operated.

Carburation

2 Dell'Orto carburetors type VHB 30 CD (right), VHB 30 CS (left).

Lubrication

Pressure, by gear pump.
Normal lubrication pressure 3,8 ÷ 4,2 kp/sqcm (controlled by relief-valve).
Electrically controlled oil pressure gauge.
Wire gauze and cartridge oil filters.

Generator

Front (14 V - 20 A) on the mainshaft.

Ignition

By battery, with double contact breaker and automatic advance.

Ignition data:

Initial advance (fixed) 2°

Automatic advance 31°

Full advance 33°

Contact breaker gap mm 0,37 ÷ 0,43

Spark plugs:

Marelli CW 7 L; BOSCH W 225; AC - 44 XL

Plug points gap mm 0,6

2 ignition coils.

Starting

Electric starter (12 V - 0,6 HP) with electromagnetic ratchet control. Ring gear bolted on flywheel. Starter button, (START) right on the handlebar.

TRANSMISSIONS

Clutch

Dry type, multiplates, flywheel driven. Lever controlled from handlebar (left).

Primary drive

via the gearbox.

Ratio: 1 : 1,235 (Z = 17/21).

Gear box

Five speeds, frontal engagement, constant mesh gears. Cush drive incorporated.

Pedal controlled from left side of the motorcycle.

Ratio:

low gear 1 : 2 (Z = 14/28)

2nd gear 1 : 1,388 (Z = 18/25)

3rd gear 1 : 1,047 (Z = 21/22)

4th gear 1 : 0,869 (Z = 23/20)

top gear 1 : 0,750 (Z = 28/21)

Secondary drive

cardan shaft (bevel gear set).

Ratio: 1 : 4,714 (Z = 7/33).

Overall gear ratio (engine/wheel):

low gear 1 : 11,643

2nd gear 1 : 8,080

3rd gear 1 : 6,095

4th gear 1 : 5,059

top gear 1 : 4,366

FRAME

Duplex cradle, tubular structure.

Suspension

Telescopic front fork incorporating sealed hydraulic dampers.

Rear swingin fork with externally adjustable springs.

Wheels

Spoked rims, WM 3/2,15 x 18 front and rear.

Tires

Front 3,50 H - 18 H or 100/90 H - 18 H.

Rear 4,10 H - 18 H or 110/90 H - 18 H.

Brakes

Front:

Hydraulic disc brake, (right) twin braking cylinder caliper. Hand lever controlled from the handlebar (R/H). Hydraulic transmission, free from rear braking system.

Disc dia. 300 mm.

Braking cylinder dia. 38 mm.

Master cylinder dia. 12,7 mm.

Twin hydraulic disc brake, (left) featured and dimensioned as above. Pedal lever controlled from the motorcycle (R/H). Hydraulic transmission, bound to rear braking system.

Rear:
 Hydraulic disc brake, twin braking cylinder caliper. Pedal lever controlled from the motorcycle (R/H).
 Disc dia. 242 mm.
 Braking cylinder dia. 38 mm.
 Master cylinder dia. 15,875 mm.
 Pedal control actuates both twin front (left) and rear brakes at the same time.

Max. height m 1,060
 Min. ground clearance m 0,150
 Curb weight kg 243

Dimensions and weights

Wheelbase m 1,470
 Max. width m 0,780
 Max. length m 2,200

PERFORMANCES

Maximum speed in each gear, solo riding:
 Gears Speed
 low gear km/h 71,837
 second gear km/h 103,502
 third gear km/h 137,339
 fourth gear km/h 165,329
 top gear km/h 195
 Fuel consumption: l. 6 x 100 km.

FUEL AND OIL CAPACITIES

GROUP OR PART	LITRES	TYPE
Fuel tank (Reserve l. 4)	24	Petrol 98/100 NO-RM
Sump	3	Agip SINT 2000 SAE 10 W/50
Gear box	0,750	Agip F.1 Rotra MP SAE 90
Rear drive box (bevel set lubrication)	0,230	Agip F.1 Rotra MP SAE 90
	0,020	Molykote type A
Front fork (each leg)	0,060	Agip F.1 ATF Dexron
Front and Rear Brakes		Agip F.1 Brake fluid SAE J 1703

CYLINDERS - PISTON - PISTON RINGS

(See fig. 182 and 183)

SELECTION OF CYLINDER DIA.

CLASS « A »	CLASS « B »	CLASS « C »
83.000	83.006	83.012
83.006	83.012	83.018

Cylinders must always be matched with pistons of same class.

SELECTION OF PISTON DIA.

CLASS « A »	CLASS « B »	CLASS « C »
82.968	82.974	82.980
82.974	82.980	82.986

Pistons must always be matched with pistons of same class.

PISTON RINGS (See fig. 183)

- n. 2 upper compression rings
 \varnothing 83 mm - thick. mm 1.478-1.490
- n. 1 intermediate oil scraper
 \varnothing 83 mm - thick. mm 1.478-1.490
- n. 1 lower oil scraper
 \varnothing 83 mm - thick. mm 3.978-3.990

— piston pin coupling:
 play mm 0.006 to a negative clearance of mm 0.004.

REMOVAL OF PIN FROM PISTON

After removal of circlips, use tool n. 13907860 (57 in fig. 181) to slide pin out of piston and con-rod small end.

PISTON PIN (See fig. 183)

- Length:
 mm 59.970-59.984 - \varnothing mm 22.000 \div 22.004.

CRANKSHAFT (See fig. 184)

The only change is in crankpin dia. (see following table):

CRANKPIN DIAMETER

SELECTION A-B	ORIGINAL \varnothing mm	OVERSIZE BEARING		
		0.254	0.508	0.762
« A » white mark on shoulder, flywheel side	44.008 \div 44.014	43.754 \div 43.766	43.500 \div 43.512	43.246 \div 43.258
« B » white mark on shoulder, flywheel side	44.014 \div 44.020			

Clearance between crankpin and bearing: min. 0.030 - max. 0.054.

Remark: Nitride treated crankshafts. For eventual adjustments send them back to « SEIMM MOTO GUZZI ».

CRANKSHAFT BALANCING

Static balancing of crankshaft is obtained by applying a weight of kg 1.586 \div 1.616.
 Max. offset in axis parallelism: crankpin and main bearing pin must not overcome mm 0,02 at mm 40.

Timing data (referred to the clearance of 1,5 mm between rocker and valve) are the following (see fig. 185):

- inlet:
 opens 20° before TDC
 closes 52° after BDC
- exhaust:
 opens 52° before BDC
 closes 20° after TDC

Normal rocker clearance (**cold engine**) mm 0.22.

TIMING DATA

(See chapter « Timing data »)

CARBURETION

CARBURETTORS (See fig. 196)

N. 2 Dell'Orto Carburetors « VHB 30 CD » (right) « VHB 30 CS » (left).

Double controls:

- throttle control grip, right on the handlebar;
- starter control lever for starting a cold engine, located on left cylinder head cover « A »: starting position, « B »: riding position.

Note:

When the starter lever is in riding position « B » ensure that there is a clearance of about 3 mm between starter control cable ends and adjuster screws on both carburetors.

STANDARD CARBURETTOR SETTING

Choke	Ø mm 30
Throttle	40
Atomizer	265
Main jet	120
Idling jet	50
Starter jet	80
Needle	V9 (2nd notch)
Float	10 grams
Idling adjuster screw: open 1 turns and a half.	

ADJUSTING THE CARBURETION (See fig. 196)

Adjusting by hand.

This adjustment is made as follows:

- 1 Get the engine at its running temperature.
- 2 Screw idling adjusting screws « C » fully in; then screw them out by one turn and a half.
- 3 By means of your hands feel if pressure at exhaust tubes is the same. In case of differences, act on screw « D » of one carburetor until the pressure will be the same (idling speed will be kept at 900-1000 r.p.m. about; consequently it will be necessary to screw in the carburetor screw of the cylinder having a lower pressure or to screw out the carburetor screw of cylinder having a higher pressure).
- 4 Get the best carburetion for each cylinder by acting on screws « C » (this will be at the point where the r.p.m. increase slightly) then get idling speed according to point 3.
- 5 Disconnect one plug lead at a time and check that the engine stops after firing 5-6 strokes. If this does not occur, get it by proceeding as follows:
 - screw out screw « D » of the cylinder causing the engine firing more than 5-6 strokes;
 - screw in screw « D » of the cylinder causing the engine firing less than 5-6 strokes.

6 Adjust idling speed to 900-1000 r.p.m. by screwing in or out in the same quantity screws « D ».

7 After closing the throttle control grip, check that there is a clearance of mm 1 ÷ 1,5 between cable ends and adjuster screws « E ».

8 Check that both gas valves open at the same time by proceeding as follows:

- Turn slowly the throttle control grip and check by means of your hands that the pressure at exhaust pipes increases simultaneously. In case such increase is not simultaneous, adjust the carburetor of the cylinder in question by screwing adjuster « E » in (after loosening its counternut) until the pressure is the same for both pipes.

ADJUSTING BY MEANS OF A « VACUUM METER »

See proper instructions in chapter « Adjusting by means of a "Vacuum Meter" ».

AIR FILTER CARTRIDGE (See fig. 28)

Every 10000 km or so, replace the air filter cartridge « A ». It is located in a proper housing which is joined to the oil breather assembly under the fuel tank.

This replacement is better done by our dealers. To remove the filter « D » from the oil breather assembly « A » proceed as follows:

- lift the saddle and fix it by its proper rod;
- remove the tool box after unhooking its holding bracket;
- unhook the fuel tank, rear side, holding bracket and slip off the fuel tank (after closing the taps and disconnecting the fuel lines);
- disconnect electrical wiring from the battery and unhook its holding brackets;
- unhook the brackets holding springs « F » and take rubber manifold « G » out of intake on carburetors and oil breather;
- unscrew nut « B » fixing the oil breather to the housing « C » and slip off the oil breather « H » (after disconnecting it from intakes and lines). Remove now the filter « D » with bottom « E » from the oil breather.

After replacing the filter by a new original one, assemble the group by reversing the above operations.

ENGINE LUBRICATION

The 850-T 3 fits an oil cleaner which in addition to a wire gauze filter is also provided with a filter cartridge.

This ensures an almost integral filtering before the oil passes in the pump and lubricating channels.

OIL SUMP (See fig. 186)

It fits:

- « A » filter cartridge, removable;
- « B » magnetic oil drain plug;
- « D » wire gauze filter;
- « E » oil pressure relief valve.

FILTER CARTRIDGE (See fig. 186)

To remove filter cartridge « A » from sump proceed as follows:

- undo plug « B » and let the oil fully drain;
- undo securing screws and remove sump « C » including:
 - filter cartridge « A »;
 - wire gauze filter « D »;
 - oil pressure relief valve « E »;
- undo filter cartridge « A » and replace it by another original one.

By this operation, wash and dry with a compressed air jet also wire gauze filter « D » before mounting sump « C » on the crankcase. Remember to replace gasket between crankcase and cover; fill up l. 3.5 of oil « Agip SINT 2000 SAE 10 W/50 ».

OIL PRESSURE RELIEF VALVE (See fig. 186)

It is screwed on the oil sump and is calibrated to allow an oil pressure of kp/sqcm 3.8-4.2 in delivery circuit.

Should pressure be higher than calibrated, this valve opens and bring pressure into fixed limits.

CHECKING THE OIL LEVEL

Every 500 km check oil level in the oil sump (level almost at max. mark on the dipstick welded to filler cap « A » (see fig. 20).

If level is lower top up with oil of same features. This checking will be carried out after engine running for a few minutes and dipstick « A » must be fully screwed.

Use oil « Agip SINT 2000 SAE 10 W/50 ».

SECONDARY DRIVE

cardan shaft (bevel gear set).

Ratio: 1 : 4,714 ($Z = 7/3$).

Overall gear ratio (engine/wheel):

low gear	1 : 11,643
2nd gear	1 : 8,080
3rd gear	1 : 6,095
4th gear	1 : 5,059
top gear	1 : 4,366

REAR DRIVE BOX

Checking the oil level (See fig. 199)

Every 3000 km (2000 miles) check that the oil level is nearly at the inspection hole « A ».

If the level is not correct, fill up with oil of the same type and features.

Changing the oil

Every 10000 km (6000 miles) change the oil in the rear drive box.

This operation should be carried out a short time after a ride when the oil is still warm and easily drained.

Remember to drain all the old oil before introducing fresh oil.

« A » inspection level plug.

« B » oil filler cap.

« C » oil drain plug.

Quantity required:

l. 0,230 of oil « Agip F. 1 Rotra MP SAE 90 »

l. 0,020 of oil « Molykote A ».

OIL LEAKAGE BETWEEN GEARBOX AND ENGINE UNIT

To detect oil leakages between gearbox and engine unit proceed as follows:

— first ascertain if the oil leaking outside comes from the gearbox or from the engine unit; this is quite easy to do by smelling the oil itself. As a matter of fact the oil coming from the gearbox smells bad and is more viscous (if this checking is done (cold-group) while the oil coming from the engine unit is less viscous and does not smell;

— if the oil comes from the gearbox, the leakage may be caused by the following:

1 Poor sealing between clutch pressure plate rod (14085700) and intermediate tube (12085901) in clutch shaft; see if the rod is very oily and slides freely into the clutch shaft (to ensure a proper sealing, the rod must force on the tube and this must force on the clutch shaft). In this case, it is advisable to check that the clutch plates are not oily.

2 Poor sealing of the ring (90403547) mounted on the gearbox, flywheel side; check ring resilience and wear, see if there is an oil drop under the ring itself. Should it be worn-out, check the surface of the clutch inner body contacting the ring in question. This surface must not be rough and must not show any crush or score.

3 If the clutch inner body (14081811) contains oil inside (where is locked the nut with washer securing the clutch inner body to the clutch shaft); check if the two sealing rings on clutch inner body and clutch shaft (90706235 and 90706235) have not lost resilience and efficiency.

4 Porosity in the gearbox; to check this, operate as follows: set the gearbox on a bench, the clutch housing side upwards (see Pict. 123); fill the clutch housing side with water and blow compressed air at 4 Kp/sqcm through the breather tube « B » (Pict. 123). In case of casting porosity, small bubbles will be visible in the water. Seal the porosity by means of latex or special plasters (Araldite or Devcon).

If the clutch slides because of oil leakages between engine unit and gearbox and the oil passes between the clutch pressure plate rod and the intermediate tube and it is ascertained that the oil comes out from the engine crankcase, this may be caused by the following:

5 Oil leaking through the seal ring mounted on the crankcase flange, flywheel side; check ring resilience and wear, if worn-out inspect the crankshaft surface contacting the ring itself. This surface must be perfectly smooth.

6 Eventual porosity in the engine crankcase; for this checking set the engine on a bench, the flywheel side upwards, « see Pict. 122 » (remove first the flywheel from the engine unit) and fill it with water, blow compressed air at 7 Kpsqcm through the breather tube «A» (Pict. 122). In case of casting porosity, small bubbles will be visible in the water. Seal the porosity by means of latex or special plasters (Araldite or Devcon).

7 If the bands securing the rubber tubes of the engine oil breather are slackened, the oil may flow between the rubber and the metal tubes going between gearbox and engine unit.

8 See if the two lower bolts securing the flange, flywheel side, (12011400) to the engine crankcase are dry; should they be oily, set some « Teflon » tape on the bolt thread.

9 See that the lower stud bolt securing the gearbox to the engine unit is not oily where the reference bushing is located (left side); otherwise set some « Teflon » tape on the stud bolt thread.

OIL LEAKAGE FROM THE REAR WHEEL DRIVE

For this checking, operate as follows:

— fit the tool « C » (Pict. 124) on the drive box (this tool can be obtained from a used rear fork right arm by welding a plate with a valve, tyre inner tube type, on the arm top);

— set the drive box into a small basin filled with water and blow compressed air through the valve of the tool «C» (Pict. 124) at 4 kp/sqcm. In case of casting porosity, small bubbles will be visible in the water. Seal the porosity by means of latex or special plasters (Araldite or Devcon).

Check also that there is no oil leaking between the drive box and the lower pin securing the rear fork. Should this pin be oily, set some « Teflon » tape on the pin thread.

N. See pages 28-29 for pictures.

REAR SUSPENSION

The rear suspension of this model can fit two different types of shock absorber springs.

The former with 5 positions, adjustable by means of an incorporated lever.

The latter with 3 positions, adjustable by means of a wrench delivered with the tool kit.

Springs data

Free length: mm 270

Under kg 61 load: mm 230

Under kg 122 load: mm 190

Under kg 235 load: mm 116

FONT SUSPENSION

FRONT FORK

Sealed damper type. See chapter « Front Suspension and steering - Inspection and checking of the front fork ».

For inspection measures see drwg. 188.
Replenishing quantity: l. 0.060 of Agip F. 1 ATF Dexron per fork member.

WHEELS AND BRAKES

The 850-T3 fits n. 3 hydraulic braking discs. The features for master cylinders calipers and discs are at page 95.

For checking and overhauling of the above parts see from page 58 to page 63.

ADJUSTING THE FRONT BRAKE (RIGHT) CONTROL LEVER (See fig. 200)

After fitting a feeler gauge between floater in master cylinder and the end of the control lever get the correct play of mm $0,05 \div 0,15$ by acting on screw « G ».

CHECKING BRAKE PADS WEARING

Every 5000 km (3000 miles) check brake pad thickness:

- new pad: mm 9;
- wear limit: mm 6 a.

If thick. is under the wear limit, it is necessary to replace the pads. After this operation has been carried out, do not drain the air but only operate the control lever on the handlebar « B » fig. 200 several times until the caliper pistons reach their normal position.

By the replacement of the pads, check the condition of the fluid pipes, should they be damaged, replace them immediately.

CHECKING THE BRAKE DISCS

(See L fig. 200 - 201)

The brake disc must be accurately clean, without oil, fat or other dirt and must not show any deep scoring.

In case of replacement or overhauling of the brake disc, it is necessary to check its wobbling. This checking is carried out by means of a proper gauge that must never read more than 0,2 mm.

Should wobbling be higher, carefully check the mounting of the disc on the hub and the play of the hub bearings.

Connection torque between disc and hub is kg/m $2,2 \div 2,4$.

CHECKING THE FLUID LEVEL AND CHANGING THE FLUID IN RESERVOIRS (See fig. 200 - 201)

For a good working of brakes these directions are to be followed:

■ periodically check the fluid level (it has to be nearly at the gaiter « E » located in the fluid reservoir « A » on the right handlebar for the right front brake and under the right battery cover for both left front and rear brakes; it has

never to be lower than 8 mm under maximum level;

■ periodically top up the fluid reservoir « A » (if necessary) after loosening the cap « F »; take the fluid from an original container which must only be opened when using the fluid;

■ completely renew the brake fluid every 15.000 km (9000 miles) or at least once a year. The fluid pipes have to be always full and without air; a long and elastic movement of the control lever « B » evidences the presence of air inside them.

Use only fresh fluid in case of washing.

No alcohol is to be used for washing and no compressed air for drying up; use Trichloroethylene for metallic parts.

Fluid to be used: « Agip F. 1 Brake Fluid ».

AIR BLEEDING (See fig. 200 - 201)

This operation is required when the movement of the control lever on the handlebar is long and elastic because of the presence of air inside the braking circuits.

Operations are as follows:

Front braking circuit, right (See fig. 141)

■ turn the handlebar until master cylinder (fluid reservoir) « A » reaches the horizontal position;

■ if necessary, top up the fluid reservoir « A » (take care that during the air draining the fluid does not go 8 mm lower than the maximum level);

■ act on a caliper body only « C » at a time:
a) take out the rubber cover, then fit a transparent flexible pipe « H » on the drain plug « D »; the other end of this duct will be plunged into a transparent container « I » partially filled up with fluid of the same type;

b) loosen the drain plug « D »;

c) completely operate several times the brake control lever « B » on the handlebar, release it slowly and wait for a few seconds before operating it again. Repeat this operation until the pipe plunged into the transparent container emits airless fluid;

d) keep the control lever « B » completely drawn and lock the drain plug « D », then remove pipe « H » and mount the rubber cover.

If the air bleeding has been correctly carried out, a direct and efficient working of the fluid will be realized immediately after the initial idle movement of the lever « B »;

otherwise repeat the whole operation.

Rear and left front braking circuits (See fig. 202)

Proceed as by the right front braking circuit but with following changes:

- point c: completely operate the control pedal « B » at the R/H side of the motorcycle.
- point d: keep the control pedal « B » completely pushed down.

ADJUSTING THE CONTROL PEDAL FOR REAR AND LEFT FRONT BRAKES (See fig. 203)

- fit a feeler gauge between floater in master

cylinder and lever end « G » then get the correct play of mm 0,05 0,15 by acting on adjuster « A »;

- remove circlip, slip out pin and loosen conternut « B »; now screw in or out fork « C » until the ideal position of control pedal « E » is reached;
- re-fit pin and circlip.

After adjusting, loosen conternut « E » and adjust lever return stop screw « D ».

REMOVAL OF WHEELS

FRONT WHEEL (fig. 19)

- undo caliper « A » securing screws and remove caliper « A » with pipe from right fork cover.
- Undo wheel spindle lock nut « B » (left side).
- Undo screws securing fork covers to wheel spindle « C ».
- Slip off spindle « D »; care the position of spacer « E ».
- Lift the motorcycle so to disengage the braking disc (left wheel side) from caliper.

To re-assemble the wheel operate vice-versa. After re-assembling check clearance between pad and disc (See chapter «Checking pad wearing»).

REAR WHEEL

- Undo the screw securing left silencer to frame; and remove silencer from exhaust tube after undoing the screw securing its fixing clamp.
- Loosen nut « B » on the spindle, drive box side.
- Undo wheel spindle securing screw « C », on rear swinging arm.
- Take spindle « D » out of drive box, wheel hub and rear swinging arm.
- Take braking disc out of caliper « E ».
- Remove caliper from stop pin on rear swinging arm; place it on motorcycle lifting hand-grip.
- Lean the motorcycle to the right so to free the wheel « F » from rear swinging arm and drive box.

To re-fit the wheel operate vice-versa.

Remember to fit caliper on the rear swinging arm (left) and to check clearance between pad and braking disc. (See proper chapter in section « Maintenance »).

ADJUSTING THE SPOKES

Check that all spokes are tightened and the wheel is correctly trued by proceeding as follows:

- spin the wheel and check its truing if necessary act on right or left spokes until the wheel turns properly. This checking has to be carried out after the first 500 km (300 miles) and later on, every 1500 km (900 miles) or so.

WHEEL BALANCE

To improve stability and decrease vibrations at high speeds the wheels have to be kept balanced.

Operations are as follows:

- after removing the wheel and checking spoke tightening and wheel truing suspend it on a fork;
 - spin the wheel lightly several times and see if it stops always in various positions, thus indicating a correct balance;
 - if one point of the wheel always stops at the bottom, put a balance weight on a spoke opposite that point.
 - repeat this operation until the wheel is correctly balanced then fix the balance weights to the spokes by means of pliers.
- Balance weights are available from our dealers in sizes of 15, 20, 30 grams. Normally, an imbalance of less than 15 grams does not affect the motorcycle stability.

TYRES

The tyre condition is of main importance as stability of motorcycle, riding comfort and even rider safety are depending on this factor.

It is therefore quite advisable not to use tyres with tread lower than 1.5 ÷ 2 mm respectively front and rear tyre.

A wrong tyre pressure can also affect stability of motorcycle and shorten type life.

Correct pressure is:

- front wheel: solo or with pillion kp/cm^2 : 2
- rear wheel: solo kp/cm^2 : 2.3
- with pillion: kp/cm^2 : 2.5.

These data are for normal riding (touring). In case of constant high speed or motorway riding increase tyre pressure 0,2 kg/cm^2 .

MAINTENANCE, INSPECTION AND ADJUSTMENT OF DOUBLE CONTACT BREAKER

Contacts gap for 850-T3 model must be within mm $0,37 \pm 0,43$.

For descriptions and adjustments see Chapter «Maintenance Inspection and Adjustment of Double Contact Breaker».

CHECKING AND ADJUSTING IGNITION TIMING (FIXED ADVANCE)

See chapter «Checking and adjusting ignition timing» considering the following changes:

TIMING OF THE R/H CYLINDER

In this position, fixed advance mark 2 is 2° from P.M.S. (TDC) «D» and so at the commencement of the point separation (see A in fig. 164).

TIMING OF THE L/H CYLINDER

In this position fixed advance mark 3 is 2° from P.M.S. (TDC) «S» and so at the commencement of the point separation (see B in fig. 164).

CHECKING THE IGNITION TIMING (FIXED ADVANCE) WITH THE ENGINE ASSEMBLED ON THE MOTORCYCLE (See fig. 165)

Only the mark «A.F.» (fixed advance) changes, namely 2° instead of 13° .

CHECKING THE IGNITION ADVANCE (FIXED AND AUTOMATIC) BY MEANS OF A STROBOSCOPE LAMP (See fig. 64 and diagram fig. 188)

Ignition data

- fixed advance: 2°
- automatic advance: 31°
- full advance (fixed and automatic): 33°

CHECKING THE FULL ADVANCE (FIXED AND AUTOMATIC)

Changes:

- A. F. (fixed advance) 2° at 1000 r.p.m. ± 200 r.p.m.
- A. T. (full advance) 33° at 6000 r.p.m. ± 200 r.p.m.

SPARK PLUGS

The 850-T 3 model fits spark plugs: Marelli CW 7 L; Bosch W 225 T 2; AC - 44 x L. For other description see chapter «Spark Plugs».

ALTERNATOR

Main Features:

- Brand: Bosch (G1 - 14V - 20A - 21")
- Drive: directly from crankshaft
- Max. output: 280 W - 14 V
- Max. amperage: 20
- Charge starting: 1000 rpm
- Peak charge: 10000 rpm
- Rotation: clockwise
(as seen from collector side)

ELECTRICAL EQUIPMENT

Starter motor

- Brand: BOSCH DF - 12 V - 06 PS
- Voltage: 12 V
- Output: 0,6 HP
- Current Intensity Ah.: 35
- Pinion: Z = 8 - mod. 2.5
- Pinion rotation: counterclockwise

ELECTRICAL TESTS

RUNNING	VOLTAGE	CURRENT	SPEED	TORQUE
Unloaded	11.5 V	$20 \div 40$ A	$6500 \div 8500$ rpm	—
Loaded	9 V	170 A	$3200 \div 3500$ rpm	kgm 0.15
Short circuit	8 V	$280 \div 360$ A	—	kgm 0.75

INSTRUMENTS AND CONTROLS

INSTRUMENT PANEL (U.S.A. MODEL) (fig. 4)

- 1 Mile counter.
- 2 Rev.-counter.
- 3 Orange neutral indicator. It lights when the gearbox is in neutral position. It may be well to make sure that this position is correct. In any case it is a good practice to pull the clutch before starting.
- 4 Red light indicating parking light on.
- 5 Red warninè light. Oil pressure gauge. It goes out when the pressure is sufficient for normal engine lubrication. Should it not go out, the pressure is not correct; in this case the engine has to be stopped and suitable checkings are to be carried out.
- 6 High beam warning light (red).
- 7 Red warning light indicating insufficient current from the generator for battery charge. It must go out when the engine reaches a certain number of revolutions.

By day riding all warning lights are to be out. By night riding the parking warning light only and eventually the high beam warning light are on.

CHANGES FOR « EUROPE MODEL »

- 1 Km counter.
- 4 Green town driving light.
- 6 High beam warning light (blue).

By night riding the town driving warning light, only and eventually the high beam warning light are on.

KEY SWITCH (fig. 5)

The key has three positions.

- « 1 » (turned anticlockwise) Standstill, key removable.
- « 0 » (vertical) Standstill, key not removable.
- « 2 » (turned clockwise) Ready to start, all controls are in. Key not removable.

LIGHTING SWITCH (LIGHTS) (fig. 207 « A »)

Left, on the handlebar, 4 positions.

- « 1 » OFF Lights off.
- « 2 » PARK Parking light (USA).
Town driving light (Europe).
- « 3 » L Low beam.
- « 4 » H High beam.
- « 5 » To come back to position OFF press the button towards the lefts.

HORN, FLASHING LIGHT AND TURN SIGNAL CONTROLS (fig. 207 « B »)

Left, on the handlebar.

- « 6 » HORN Horn button.
- « 7 » FLASH Flashing light button.
- « 8 » OFF Turn signals button.
- « 9 » When turned to the right operates the right signals.
- « 10 » When turned to the left operates the left signals.

ENGINE STARTING AND EMERGENCY STOPPING (fig. 208)

Right, on the handlebar.

With the ignition key in position « 2 » in fig. 206 the motorcycle is ready to be started. To start the engine (see « A ») press the button « 1 » START.

To stop the engine (in case of emergency) turn the button in position « 3 » or « 4 » OFF.

After engine stopping reset key in position « O » fig. 206.

GEARSHIFT PEDAL (fig. 209)

On the left side of the motorcycle.

Low gear: pedal down.

2. 3. 4. and top gear: pedal up.

Neutral position: between low and 2 nd gear.

Before operating the gearshift pedal, the clutch lever has to completely pulled in.

TERMINAL BLOCK WITH FUSES (fig. 210)

It is locate dunder the seat and holds n. 6 15 A fuses.

- « 1 » Rear stop light horn, flashing light.
- « 2 » Starting relay. Turn signals.
- « 3 » Warning lights. Oil-gen-N Low - High beam with warning light.
- « 4 » Parking or town driving lights - Instruments.
- « 5 » { Spare fuse.
- « 6 » }

STEERING LOCKING (« A » in fig. 211)

To lock:

- turn handlebar fully to the right.
- insert key into lock set, turn it anticlockwise and push it fully in, release it and take it off.

To release:

- insert key into lock set, turn it anticlockwise release it and take it off.

LIGHTS (Europe model)

HEADLIGHT

- high and low beam: bulb 45/40 W - 12 V
- town driving light: bulb 3 W - 12 V

TAIL LIGHT

- number plate lighting, parking light and stop light: bulb 5/21 W - 12 V.

Indicators, instrument panel: bulb 1,2 W - 12 V.
Indicators, km and rev. counters: bulb 3 W - 12 V.

REPLACEMENT OF BULBS (fig. 212)

HEADLIGHT

- Undo screw « B », disconnect beam insert, slip off sockets and replace bulbs.

TAIL LIGHT

- Undo screws « C » securing reflector to tail light; push bulb inwards and turn it to the left at the same time, then slip it off.

TURN SIGNALS

- Undo screws « D » securing reflectors to signal lights; push bulbs inwards and turn them to the left at the same time, then slip them off.

By re-fitting of reflectors screw in uniformly, do not lock screws too much to prevent braking of same.

INSTRUMENT PANEL, KM AND REV. COUNTERS

- Slip off bulb sockets and replace bulbs.

HEADLIGHT BEAM ADJUSTING (fig. 212)

For a safe riding and not to trouble crossing riders, the headlight beam has always to be set a correct height.

For horizontal setting act on screw « A ».

For vertical setting undo connections « E » and shift the headlight by hand up or down in order to get the correct height.

The centre of the high beam must not be higher than 0,86 m measured at 3 m distance with motorcycle not on stand and rider on saddle.

WIRING DIAGRAM (Europe model)

(fig. 213)

- | | |
|---|--|
| 1 - Km counter | 22 - Alternator (14 V - 20 A) |
| 2 - Rev. counter | 23 - Starter motor relay |
| 3 - High beam indicator light | 24 - Starter motor (12 V - 0,7 HP) |
| 4 - Oil pressure indicator light | 25 - Clutch cable cutout |
| 5 - Neutral indicator light | 26 - Left rear turn signal |
| 6 - Town driving indicator light | 27 - Rear brake stop light |
| 7 - Generator charge indicator light | 28 - Number plate and town driving light |
| 8 - Low beam | 29 - Right rear turn signal |
| 9 - High beam | 30 - Flasher unit |
| 10 - Right front turn signal light | 31 - Oil pressure cutout |
| 11 - Left front turn signal light | 32 - Neutral position cutout |
| 12 - Engine starting and stopping switch | 33 - Terminal block with fuses (16 A) |
| 13 - Lighting switch | 34 - 3-way connector |
| 14 - Switch; turn signal, starting, horns, flashing light | 35 - 4-way connector (AMP) |
| 15 - Horns Power 7 A) | 36 - Contact breaker |
| 16 - Front brake stop light cutout | 37 - Coils |
| 17 - Flashing light relay | 38 - Ignition switch (3 positions) |
| 18 - Rear brake stop light cutout | 39 - 4-way connector (AMP) |
| 19 - Battery (12 V - 32 Ah) | 40 - 2-way connector |
| 20 - Regulator | 41 - Spark plugs |
| 21 - Rectifier | 42 - Town driving light, front |

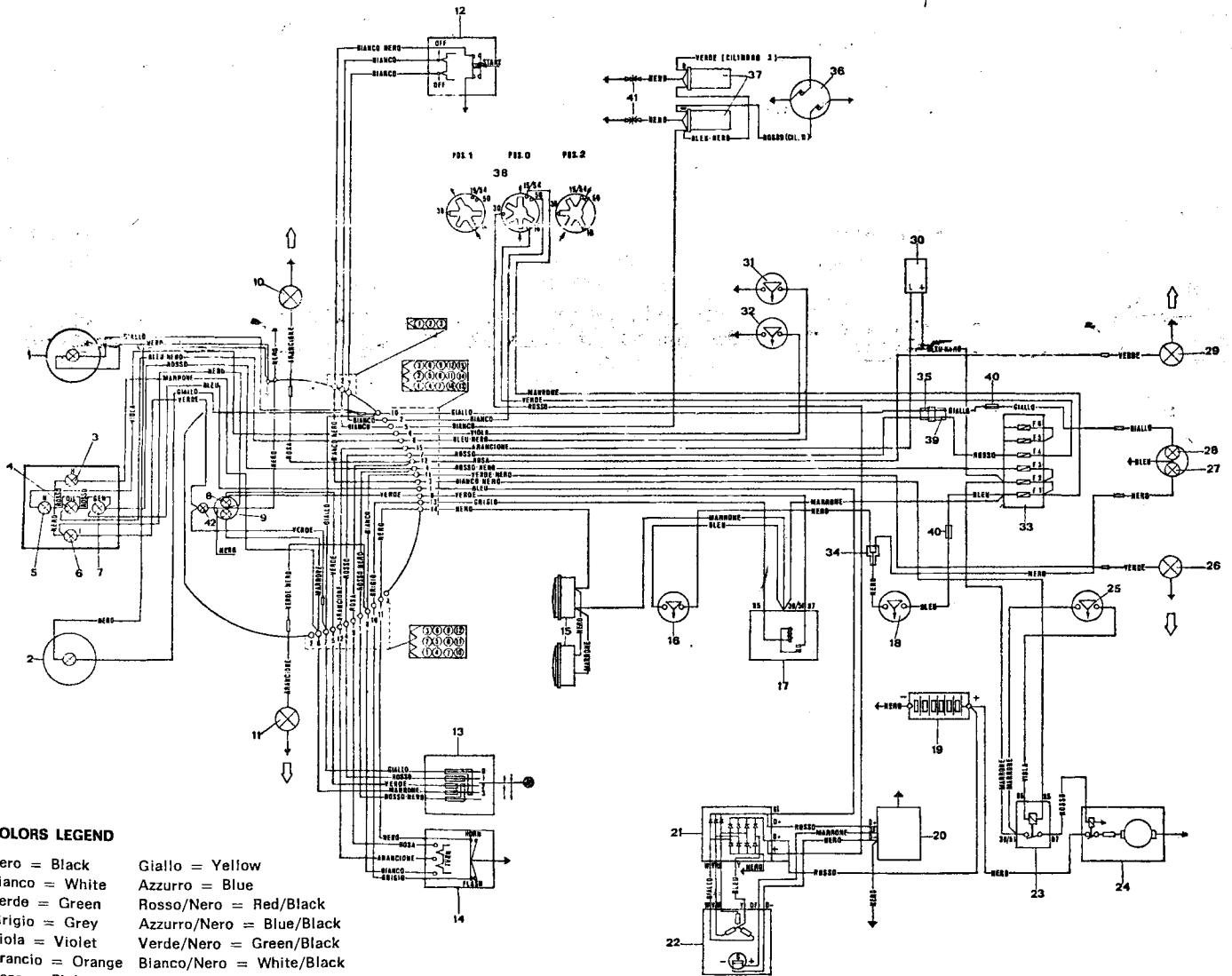

COLORS LEGEND

- | | |
|------------------|----------------------------|
| Nero = Black | Giallo = Yellow |
| Bianco = White | Azzurro = Blue |
| Verde = Green | Rosso/Nero = Red/Black |
| Grigio = Grey | Azzurro/Nero = Blue/Black |
| Viola = Violet | Verde/Nero = Green/Black |
| Arancio = Orange | Bianco/Nero = White/Black |
| Rosa = Pink | Giallo/Nero = Yellow/Black |
| Rosso = Red | Grigio/Nero = Grey/Black |
| Marrone = Brown | Grigio/Rosso = Grey/Red |

LIGHTS (U.S.A. model)

HEADLIGHT

- Sealed beam insert type: 45/40 W - 12 V.

TAIL LIGHT

- Number plate lighting parking light and stop light: bulb 5/21 W - 12 V.

Turn signals: 21 W - 12 V.

Indicators, instrument panel: bulb 1,2 W - 12 V.

Indicators, mile and rev. counters: bulb 3 W - 12 V.

REPLACEMENT OF BULBS (fig. 212/1)

TAIL LIGHT

- Undo screws « C » securing reflector to tail light; push bulb inwards and turn it to the left at the same time, then slip it off.

TURN SIGNALS

- Undo screws « D » securing reflectors to signal lights; push bulbs and turn them to the left at the same time, then slip them off.

By re-fitting of reflectors screw in uniformly, do not lock screws too much to prevent braking of same.

INSTRUMENTS PANEL, MILE AND REV. COUNTERS

- Slip off bulb sockets and replace bulbs.

HEADLIGHT BEAM ADJUSTING (fig. 212/1)

For a safe riding and not to trouble crossing riders, the headlight beam has always to be set at a correct height.

For horizontal setting act on screw « A ».

For vertical setting undo connections « E » and shift the headlight by hand up or down in order to get the correct height.

The centre of the high beam must not be higher than 0,86 m measured at 3 m distance with motorcycle not on stand and rider on saddle.

CHANGING THE WIRING DIAGRAM FOR VEHICLES WITH COMPULSORY LIGHTING ON, WHEN STARTING THE ENGINE

To achieve this change it is necessary to take off the wire group which connects connector « 35 » to fuse n. 4 (red cable) and to connection « 40 » (yellow cable). This wire group is connected to connector « 35 » through connector « 39 ».

After disconnecting the yellow cable (rear parking light) from connector « 40 », connect it to fuse n. 4 as indicated in the wiring diagram. Connector « 35 » will be re-fitted, into the insulated housing which supports the flasher unit for turn signals.

This change accomplished, notice that instrument lights and indicator light « I » (Low beam) are not protected by fuse n. 4 but by fuse n. 3.

**ADDITIONS AND CHANGES
FOR 850-T3 - EUROPE POLICE MODEL**

INSTRUMENTS AND CONTROLS

INSTRUMENT AND PANEL (fig. 214)

- 1 Km counter, speedometer.
- 2 Left turn indicator warning light (green).
- 3 Right turn indicator warning light (green).
- 4 « H » high beam warning light (blue).
- 5 « N » neutral position warning light (orange).
- 6 « Gen » warning light indicating insufficient battery charge from generator (red).
- 7 « Oil » warning light indicating insufficient oil pressure (red).
- 8 « Park » warning light (green) indicating side stand in parking position.
- 9 « I » warning light, parking (green).
- 10 « Purs » warning light (red) indicating red lights on.
- 11 « Rad » warning light (red) indicating radio on.
- 12 « Light » switch for additional lights.
- 13 « Emerg » switch controlling simultaneous flashing of rear turn indicator lights (the switch controls also the flashing of warning lights « 2 » and « 3 »).
- 14 Odometer reset.

CONTROL BUTTONS FOR RADIO, SIRENE AND ADDITIONAL LIGHTS (fig. 215)

This group is mounted on the right handlebar:

- « 1 » Radio control button (white).

- « 2 » Sirene control button (blue).
- « 3 » Red lights control (red).
- « 4 » Sirene control (blue).

TERMINAL BLOCK WITH FUSES (fig. 211)

The terminal block is located on the right side of the motorcycle.

Access to the terminal block is made possible by removal of the right motorcycle side cover and terminal block cover.

It incorporates n. 6 16 A fuses.

Key controlled

- « 1 » Rear stop light, horns, flashing lights.
- « 2 » Starter motor relay.
- « 3 » Warning lights: « Oil - Gen - N » - Headlight: high beam, low beam and warning lights.
- « 4 » Rear parking lights, instrument lighting, warning light « I » rear red lights.

Out of key control

- « 5 » Additional lights and warning light « Purs »; additional light.
- « 6 » Turn indicator lights with their warning lights.

WIRING DIAGRAM

(fig. 216)

- 1 - Km counter, speedometer (bulb 3 W)
- 2 - Additional light (bulb 5 W)
- 3 - « H » high beam warning light (bulb 1,2 W)
- 4 - « Oil » Oil pressure warning light (bulb 1,2 W)
- 5 - « N » Neutral position warning light (bulb 1,2 W)
- 6 - « L » Low beam and parking warning light (bulb 1,2 W)
- 7 - « Gen » Generator warning light
- 8 - Low beam } bulb 40/45 W
- 9 - High beam }
- 10 - Turn indicator light, front/right (bulb 21 W)
- 11 - Turn indicator light, left/front (bulb 21 W)
- 12 - Engine starting and stopping control
- 13 - Additional light switch
- 14 - Control switch: turn indicator lights, horns, flashing
- 15 - Horn (Consumption 7 A)
- 16 - Front brake switch
- 17 - Flashing light relay
- 18 - Rear brake switch
- 19 - Battery
- 20 - Regulator
- 21 - Rectifier
- 22 - Alternator (14 V - 20 A)
- 23 - Starter motor relay
- 24 - Starter motor
- 25 - Switch on clutch control wire
- 26 - Turn indicator light - rear/left (bulb 21 W)
- 27 - Rear stop light (bulb 21 W)
- 28 - Number plate and tail light (bulb 5 W)
- 29 - Turn indicator light - rear/right (bulb 21 W)
- 30 - Turn indicator lights flasher unit
- 31 - Oil pressure switch
- 32 - Neutral position cutout
- 33 - Terminal block with fuses (16 A fuses)
- 34 - 3-way connector

- 35 - 4-way connector (Amp)
- 36 - Breaker
- 37 - Coils
- 38 - Ignition switch (3 positions)
- 39 - Control actuating simultaneous flashing of turn indicator lights
- 40 - 2-way connector
- 41 - Spark plugs
- 42 - Light switch with travel limit from position « High/Low beam » to position « Parking light »
- 43 - Right turn indicator warning light (bulb 1,2 W)
- 44 - Left turn indicator warning light (bulb 1,2 W)
- 45 - « Park » Side stand parking position warning light (bulb 1,2 W)
- 46 - « Purs » Red pursuing lights warning lights (bulb 1,2 W)
- 47 - « Rad » Radio warning light (bulb 1,2 W)
- 48 - 4-way connector (Amp)
- 49 - Connection
- 50 - Red pursuing lights (front) - (bulb 35 W)
- 51 - Control: red lights - radio - syrene
- 52 - Syrene relay
- 53 - Coil control device
- 54 - Control device for side stand warning light
- 55 - Syrenes
- 56 - Front parking light (bulb 3 W)
- 57 - Spare fuse

The devices no. 53 and no. 54 and cables « A - B - C - D » are supplied only on request: when the above parts are not installed, the white cable coming from clamp no. 5 (15-way Molex - Headlight) must be connected directly on to the coil (connection no. 40 to be eliminated).

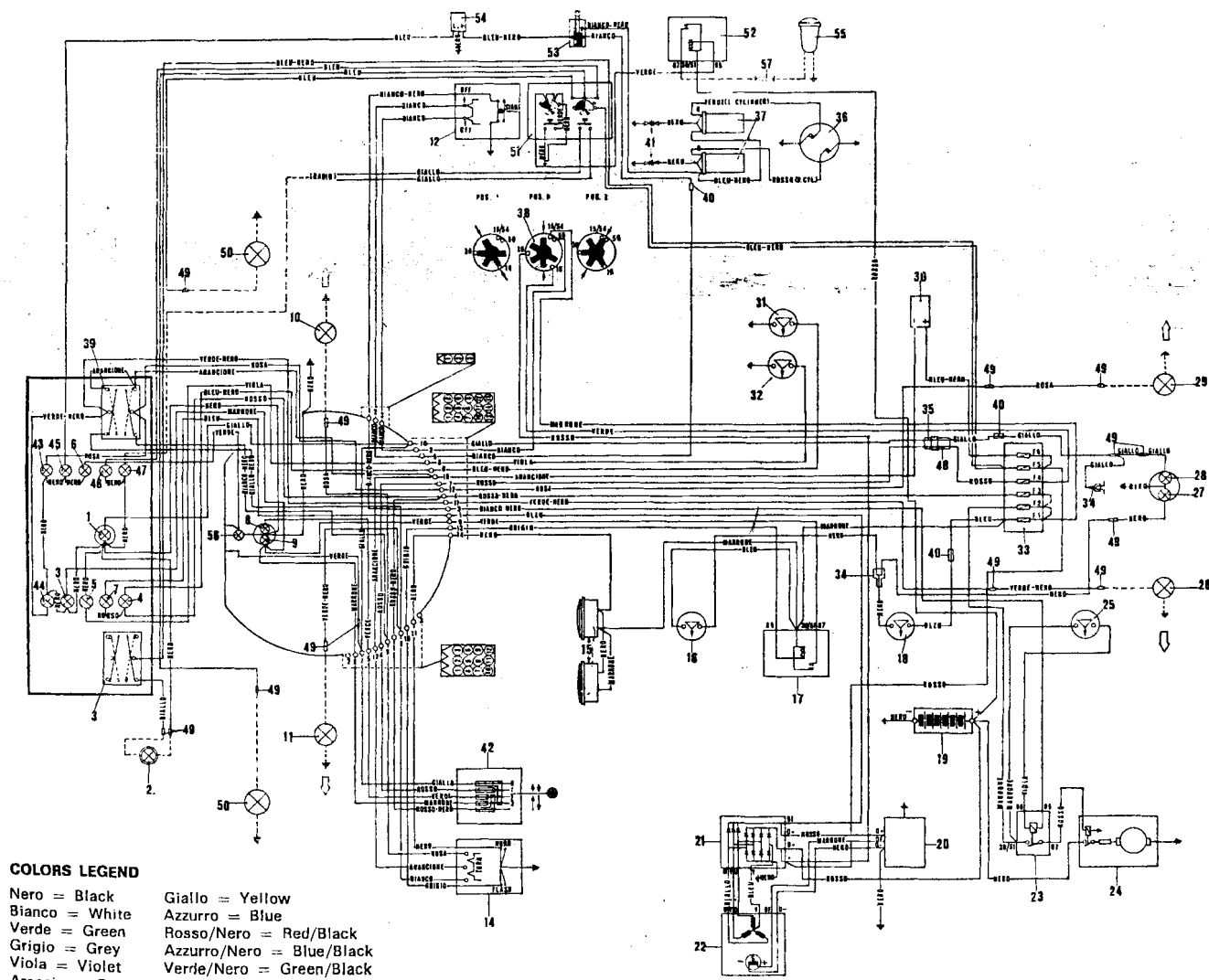

COLORS LEGEND

- | | |
|------------------|----------------------------|
| Nero = Black | Giallo = Yellow |
| Bianco = White | Azzurro = Blue |
| Verde = Green | Rosso/Nero = Red/Black |
| Grigio = Grey | Azzurro/Nero = Blue/Black |
| Viola = Violet | Verde/Nero = Green/Black |
| Arancio = Orange | Bianco/Nero = White/Black |
| Rosa = Pink | Giallo/Nero = Yellow/Black |
| Rosso = Red | Grigio/Nero = Grey/Black |
| Marrone = Brown | Grigio/Rosso = Grey/Red |

**ADDITIONS AND CHANGES
FOR 850-T3 - "LAPD,, POLICE MODEL (USA)**

INSTRUMENTS AND CONTROLS

INSTRUMENT PANEL (fig. 214/1)

- 1 Mile counter, speedometer.
- 2 Left turn indicator warning light (green).
- 3 Right turn indicator warning light (green).
- 4 « H » high beam warning light (red).
- 5 « N » neutral position warning light (orange).
- 6 « Gen » warning light indicating insufficient battery charge from generator (red).
- 7 « Oil » warning light indicating insufficient oil pressure (red).
- 8 « Park » warning light (green) indicating side stand in parking position.
- 9 « L » warning light, parking (red).
- 10 « Purs » warning light (red) indicating red lights on.
- 11 « Rad » warning light (violet) indicating radio on.
- 12 « Light » switch for additional lights.
- 13 « Emerg » switch controlling simultaneous flashing of rear turn indicator lights (the switch controls also the flashing of warning lights « 2 » and « 3 »).
- 14 Odometer reset.

CONTROL BUTTONS FOR RADIO, SIRENE AND RED LIGHTS (fig. 215/1)

This group is mounted on the right handlebar:
« 1 » Radio control button (white).

- « 2 » Sirene control button (blue).
- « 3 » Red lights control (red).
- « 4 » Sirene control (blue).

TERMINAL BLOCK WITH FUSES (fig. 211)

The terminal block is located on the right side of the motorcycle.

Access to the terminal block is made possible by removal of the right motorcycle side cover and terminal block cover.

It incorporates n. 6 16 A fuses.

Key controlled

- « 1 » Rear stop light, horns, flashing lights.
- « 2 » Starter motor relay.
- « 3 » Warning lights: « Oil - Gen - N » - Headlight: high beam, low beam and warning lights.
- « 4 » Rear parking lights, instrument lighting, warning light « L » rear blue lights.

Out of key control

- « 5 » Red lights and warning light « Purs »; additional light.
- « 6 » Turn-indicator lights with their warning lights.

WIRING DIAGRAM

(fig. 216/1)

- | | |
|---|---|
| 1 - Mile counter, speedometer (bulb 3 W) | 35 - 4-way connector (Amp) |
| 2 - Additional light (bulb 5 W) | 36 - Breaker |
| 3 - « H » high beam warning light (bulb 1,2 W) | 37 - Coils |
| 4 - « Oil » Oil pressure warning light (bulb 1,2 W) | 38 - Ignition switch (3 positions) |
| 5 - « N » Neutral position warning light (bulb 1,2 W) | 39 - Control actuating simultaneous flashing of turn indicator lights |
| 6 - « L » Low beam (bulb 1,2 W) | 40 - 2-way connector |
| 7 - « Gen » Generator warning light | 41 - Spark plugs |
| 8 - Low beam } bulb 40/45 W | 42 - Light switch with travel limit from position « High/Low beam » to position « Parking light » |
| 9 - High beam } | 43 - Right turn indicator warning light (bulb 1,2 W) |
| 10 - Turn indicator light, front/right (bulb 21 W) | 44 - Left turn indicator warning light (bulb 1,2 W) |
| 11 - Turn indicator light, left/front (bulb 21 W) | 45 - « Park » Side stand parking position warning light (bulb 1,2 W) |
| 12 - Engine starting and stopping control | 46 - « Purs » Red pursuing lights warning lights (bulb 1,2 W) |
| 13 - Additional light switch | 47 - « Rad » Radio warning light (bulb 1,2 W) |
| 14 - Control switch: turn indicator lights, horns, flashing | 48 - 4-way connector (Amp) |
| 15 - Horn (Consumption 7 A) | 49 - Connection |
| 16 - Front brake switch | 50 - Red pursuing lights (front) - (bulb 35 W) |
| 17 - Flashing light relay | 51 - Control: red lights - radio - syrene |
| 18 - Rear brake switch | 52 - Syrene relay |
| 19 - Battery | 53 - Coil control device |
| 20 - Regulator | 54 - Control device for side stand warning light |
| 21 - Rectifier | 55 - Syrenes (90 W) |
| 22 - Alternator | 56 - Rear blue lights (bulb 5 W) |
| 23 - Starter motor relay | 57 - Spare fuse |
| 24 - Starter motor | |
| 25 - Switch on clutch control wire | |
| 26 - Turn indicator light - rear/left (bulb 21 W) | |
| 27 - Rear stop light (bulb 21 W) | |
| 28 - Number plate and tail light (bulb 5 W) | |
| 29 - Turn indicator light - rear/right (bulb 21 W) | |
| 30 - Turn indicator lights flasher unit | |
| 31 - Oil pressure switch | |
| 32 - Neutral switch | |
| 33 - Terminal block with fuses (16 A fuses) | |
| 34 - 3-way connector | |

The devices no. 53 and no. 54 and cables « A - B - C - D » are supplied only on request: when the above parts are not installed, the white cable coming from clamp no. 5 (15-way Molex - Headlight) must be connected directly on to the coil (connection no. 40 to be eliminated).

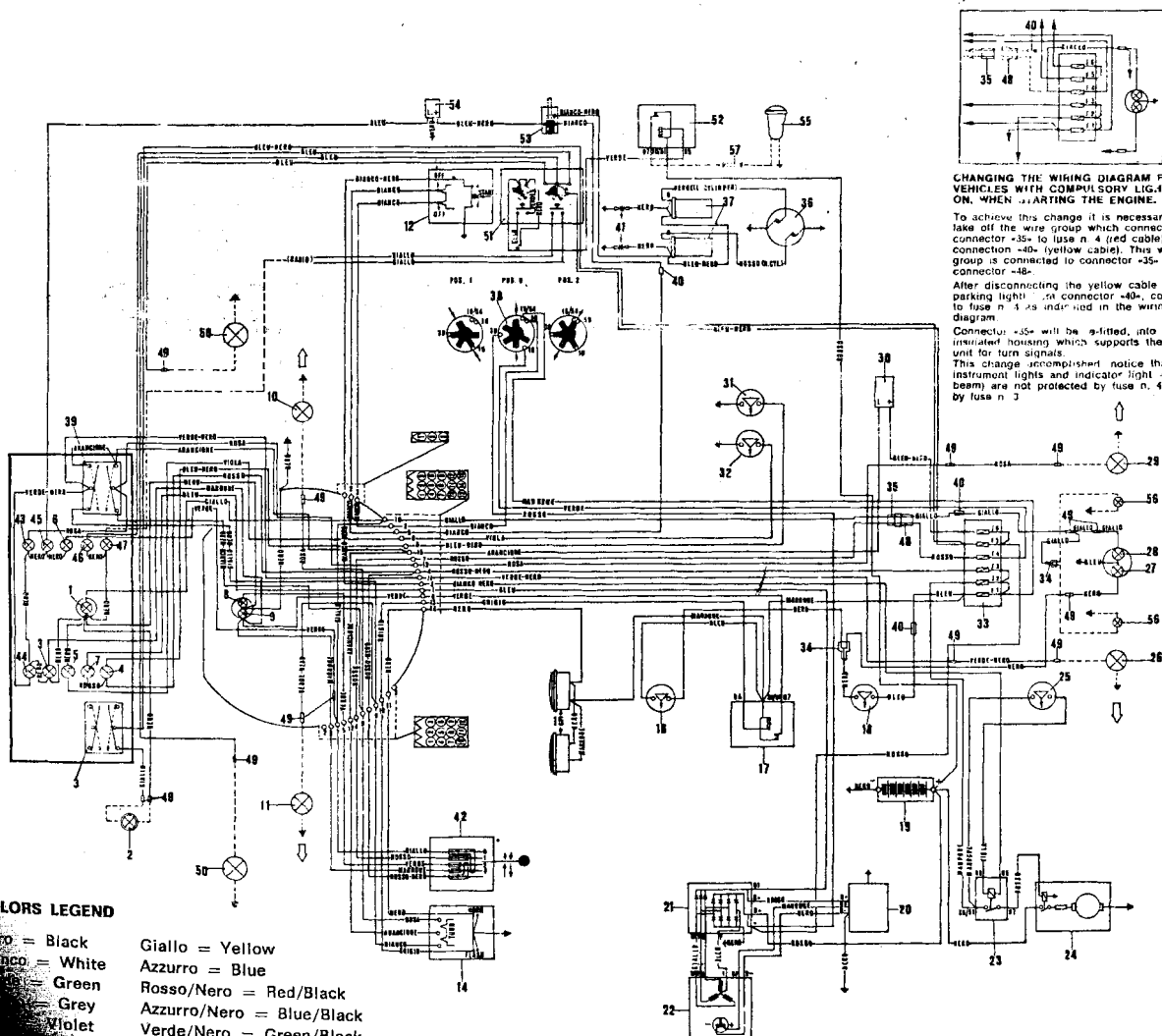

COLORS LEGEND

- | | |
|--------------------|----------------------------|
| Nero = Black | Giallo = Yellow |
| Bianco = White | Azzurro = Blue |
| Verde = Green | Rosso/Nero = Red/Black |
| Grigio = Grey | Azzurro/Nero = Blue/Black |
| Violetto = Violet | Verde/Nero = Green/Black |
| Arancione = Orange | Bianco/Nero = White/Black |
| | Giallo/Nero = Yellow/Black |
| | Grigio/Nero = Grey/Black |
| | Grigio/Rosso = Grey/Red |

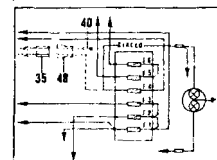

CHANGING THE WIRING DIAGRAM FOR VEHICLES WITH COMPULSORY LIGHTING ON WHEN STARTING THE ENGINE.

To achieve this change it is necessary to take off the wire group which connects connector +35 to fuse n. 4 (red cable) and to connection +40 (yellow cable). This wire group is connected to connector +35 through connector +48.

After disconnecting the yellow cable (rear parking light) at connector +40, connect it to fuse n. 4 as indicated in the wiring diagram.

Connector +35 will be re-fitted into the original housing which supports the flasher unit for turn signals. This change accomplishes notice that instrument lights and indicator light 14 (Low beam) are not protected by fuse n. 4 but by fuse n. 3.